

6. Plot Guide

6.6 Plot D2

6.6.12 Material Appearance

Hard-wearing and long-life quality materials should be selected. This should take inspiration from the existing local façade colours, textures and materials and new or complementary material types can be introduced where appropriate.

Care should be taken when sourcing all materials to ensure minimum environmental impact and the sustainable credentials of the source and the materials lifecycle, see Chapter 6.9 of SWSH Visioning Framework Sustainability Statement for further guidance.

The inner courtyards to the residential neighbourhoods form a series of more informal, human scale experiences along the lane way characterised by community gardens and a finer grain to the architectural detailing and use of materials. This is in contrast to the more robust, formal elevational treatments to the outward facing elevations of the residential neighbourhoods that form the edges to major streets and routes.

The primary material palette for the façade of the D2 Neighbourhoods typology should be drawn from both the St Helier local stone types as full stone clad items in conjunction with a mix of re-constituted stone 'frame and infill' approaches.

The secondary material palette for areas of roof of Plot D2 could include various 'infill' material options to add life, vibrancy and character to the residential neighbourhoods.

The tertiary material palette for all framing, detailing and areas of variation or highlight within inset infill zones, balconies, balustrades and openings across façades of Plot D2 could include an expanded palette of metals including wood, terracotta, glazed brick/tile and ceramic elements, with associated pattern and texture/relief options for further interest.

6.6.12.1 - Warm and restrained natural tones of stone should be considered in particular local, or equivalent granites, limestones, and equivalent reconstituted stones in a similar tone where a building is completely stone clad.

6.6.12.2 - Warm and restrained natural tones of stone, reconstituted stones and concretes should be used for the overall enclosure or 'frame' where a building is utilising the 'frame and infill' approach.

6.6.12.3 - Material selection should consider material used on neighbouring plot façades.

6.6.12.4 - Material selection should be responsive to the neighbouring Horizon buildings.

6.6.12.5 - Materials palette used in the inner courtyards should use a finer grain of architectural detailing to create 'softer' approach as set in the Neighbourhoods typology.

6.6.12.6 - Promotion of the use of materials that incorporate recycled content and procuring products with a low environmental impact should be a priority when choosing materials. For further guidance see Chapter 6.9 of SWSH Visioning Framework Sustainability Statement.

6.6.12.7 - The secondary material palette should be complementary to the primary composition.

6.6.12.8 - The materials palette for areas of façade that extend to form roof upstands should either be formed from the primary palette or include various 'infill' material options to add life, vibrancy and character.

6.6.12.9 - The tertiary material palette should be complementary to the primary and secondary composition.

6.6.12.10 - Exuberant and varied palettes of materials should be used as the tertiary palette to introduce patterning, texturing and finer detail.

6.6.12.11 - All materials should be hard wearing and suitable for a marine environment.

6.6.12.12 - Colours for the window frames, door frames, balcony metalwork and other architectural and design features must be complementary to the materials used on the rest of the building.

PRIMARY PALETTE



Figure 6.467 Limestones



Figure 6.468 Re-constituted Stone



Figure 6.469 Granites

SECONDARY AND TERTIARY PALETTES



Figure 6.471 Concrete, light brick as well as GRCs and metals

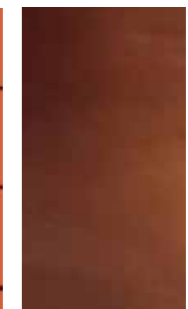

Figure 6.472 Acetylated or equivalent woods, terracotta, pre-oxidised and/or sealed/ coated pre-weathered metals and glazed brick/ tiles

This Page is Left Intentionally Blank

6. Plot Guide

6.7 Plot E1

6.7.2 Plot Overview

Plot E1 is part of the Neighbourhood typology, with a calm 'neighbourhood' feel designed to support a new community of waterfront residents keen to live, work and play in St Helier and well supported by local shops and community provision.

Figure 6.478 demonstrates how Plot E1 is located within the illustrative landscape framework, providing key plot dimensions. The building encloses a semi private communal garden to the west and holds a key elevation along La Route de la Libération.

For further details on dimensions of key routes and codes relating to Plot E1's relationship with the public realm please refer to Chapter 4 - Prescription of future development - Public realm and Open space, of this document set.

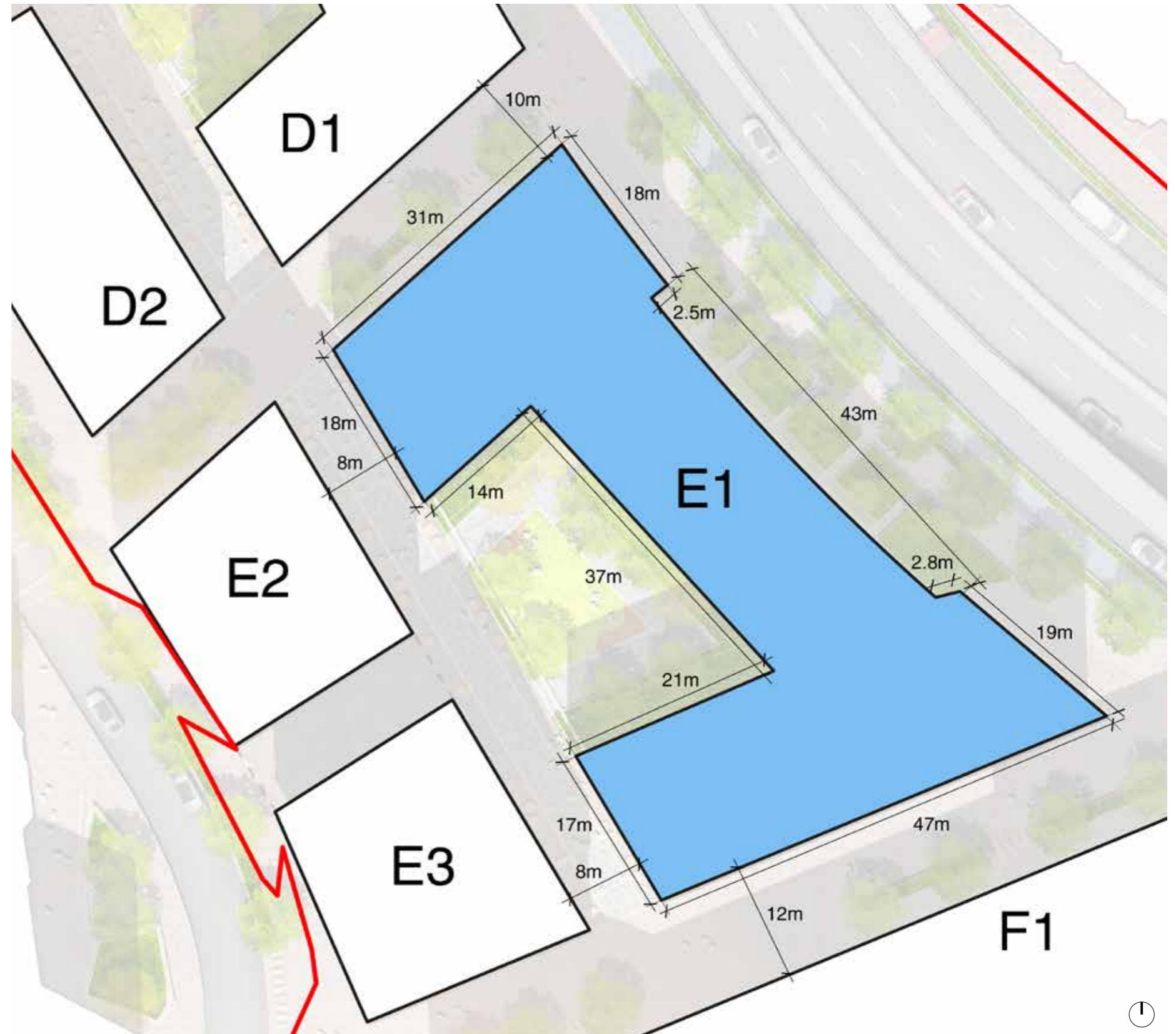

Figure 6.478 Ground floor plan

6. Plot Guide

6.7 Plot E1

6.7.3 General Appearance

E1 GENERAL APPEARANCE

The analysis in section '5.8 Approach to Architecture' in the design and access statement indicates the plot should respond in scale and façade articulation to the adjacent character areas. The overall approach is to create a high quality building with a distinct frontage that contributes to the identity of the Neighbourhoods.

The architectural language of each façade should be consistent although the composition may vary to respond to specific considerations e.g. proximity to neighbouring plots and daylight/sunlight.

6.7.3.1 - The elevations should respond appropriately to their setting and their expression should complement the architectural language of plots D1, E2, E3 and F1.

6.7.3.2 - Plot E1 is part of the Neighbourhoods typology. All elevations should respect their typology as well as consider adjacent typologies including the Leisure Quarter and Commercial Quarter opposite.

6.7.3.3 - Windows should have deep reveals to provide adequate depth to the façade.

6.7.3.4 - The building envelope must define a clear bottom, middle and top through the architectural expression and treatment of the façade. See figure 6.494.

6.7.3.5 - Consideration must be given to how the building interfaces with the ground and the skyline with particular attention to the roofscape in order to create a varied roofline.

6.7.3.6 - Consideration must be given to how duplex units are integrated into the building at ground floor level in order to create a varied first floor datum as illustrated in figure 6.479.

6.7.3.7 - There must be depth and layering in the articulation of the façades to provide a sense of quality.

6.7.3.8 - The architectural language should use a blend of punched and expressed windows with frame reveals and full height windows and infill to expressed structural frame to all elevations.

6.7.3.9 - Variations in depth, height and materials should be used to break down the horizontal elevation into distinct vertical proportions. See figure 6.480.

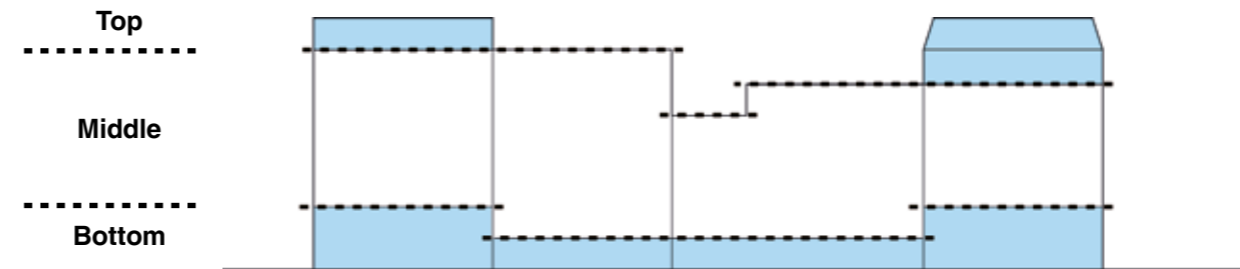

Figure 6.479 Plot E1 - The eastern elevation of the Neighbourhoods typology top, middle and bottom clearly defined by ground and roof treatments

6. Plot Guide

6.7 Plot E1

6.7.4 Wind mitigation

E1 WIND MITIGATION

The impact of wind on the public and private realm environment should be mitigated by the incorporation of design features highlighted in the SWSH Visioning Framework Wind and Microclimate Assessment.

6.7.4.1 - Rooftop enclosures to E1 terraces must be considered as indicated in section 6.8.6 - Top of the Building.

6.7.4.2 - Rooftop balustrades and set backs must be considered as indicated in section 6.8.6 - Top of the Building.

6.7.4.3 - Corner inset balconies must be considered as indicated in the section 6.8.11 - Balconies and figure 6.499 opposite.

6.7.4.4 - Awnings should be considered for retail runs.

6.7.4.5 - Inhabited mansard/pitched roofs must be considered as indicated to assist with wind mitigation on inhabited terraces. See figure 6.481.

6.7.4.6 - Wind mitigation solutions should be complementary to overall architectural typology design and integrated into the building design.

6.7.4.7 - The design of plot E1 must incorporate wind mitigation measures as identified in the wind chapter of the EIS, or alternative equivalent measures to achieve the same mitigation effect developed and tested through detailed design.



Figure 6.481 Inhabited pitch/mansard roofs for wind mitigation

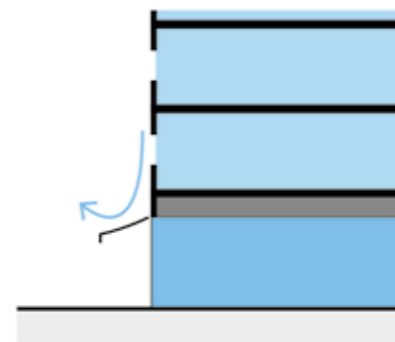

Figure 6.482 Awnings for wind mitigation

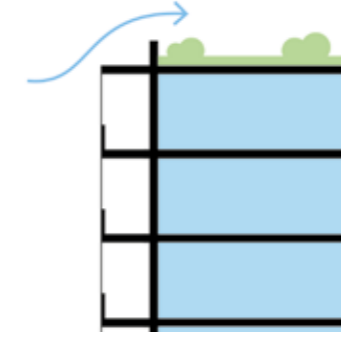

Figure 6.483 Upstand for wind mitigation

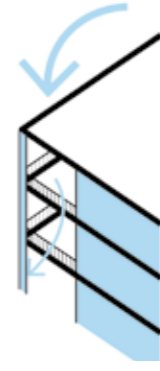

Figure 6.484 Inset balconies on corners for wind mitigation



Figure 6.485 Example of an inhabited roof terrace



Figure 6.486 Example of awnings



Figure 6.487 Example of 1.1m upstand



Figure 6.488 Example of inset balconies

6. Plot Guide

6.7 Plot E1

6.7.5 Massing

E1 MASSING

A maximum AOD has been established for Plot E1. The maximum AOD steps down towards the west as well as the centre of the plot, providing variance in the massing.

Plot E1 has defined maximum shoulder heights on multiple façades. Within these datums, the building is to have set backs, mansard with dormer or pitched and flat roof treatments. This aims to reduce the perceived building height and add variation to the overall roofscape.

6.7.5.1 - The ground floor should have additional height to accommodate retail and residential duplexes uses. See figure 6.489 below.

6.7.5.2 - Identified roof zone should have a variation in roof profile. See figure 6.490.

6.7.5.3 - The maximum number of storeys permissible for Plot E1 is 8 storeys (ground plus 7), stepping down to 5 storeys (ground plus 4) towards the west and centre of the plot. See figure 6.491 for indicative floor to floor setting out.

6.7.5.4 - Figures 6.490 identifies the maximum shoulder heights permissible.

6.7.5.5 - Balustrades and privacy screens may project above the shoulder height provided they are contained within the accessible terrace zone as indicated in figure 6.491.

Legend

- Maximum plot parameters
- +6.3m floor to floor bottom zone
- Indicative shaped massing where applicable
- Suggested roof treatment and accessible terrace zones



Figure 6.489 Typical floor to floor

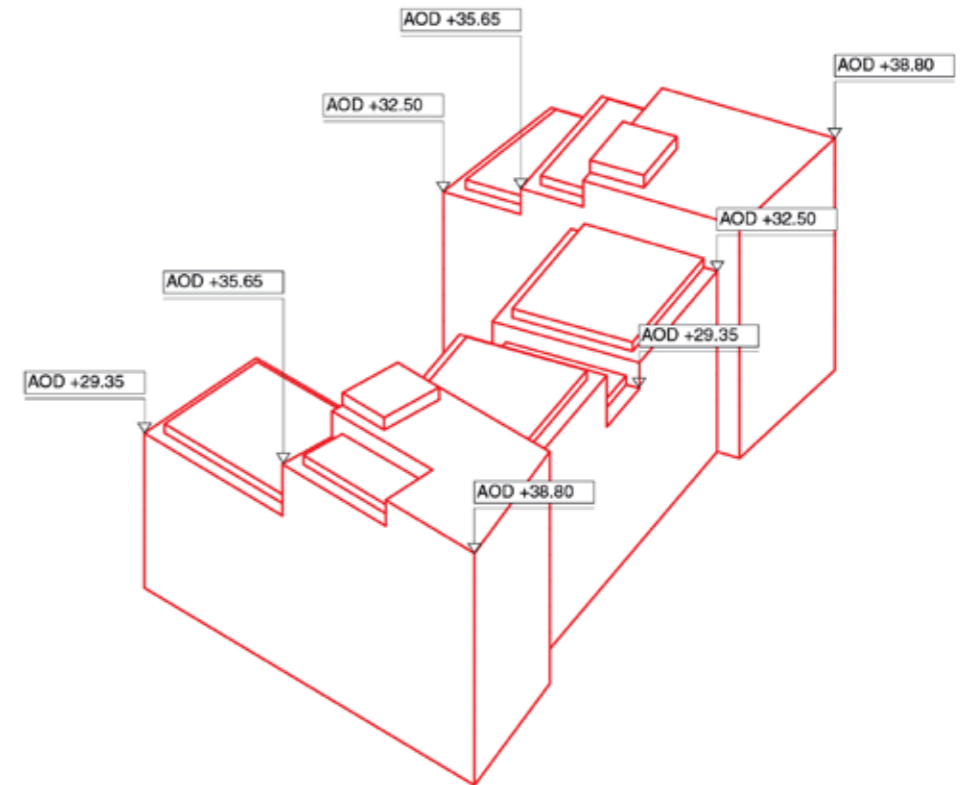

Figure 6.490 Plot E1 Maximum plot parameters showing shoulder heights

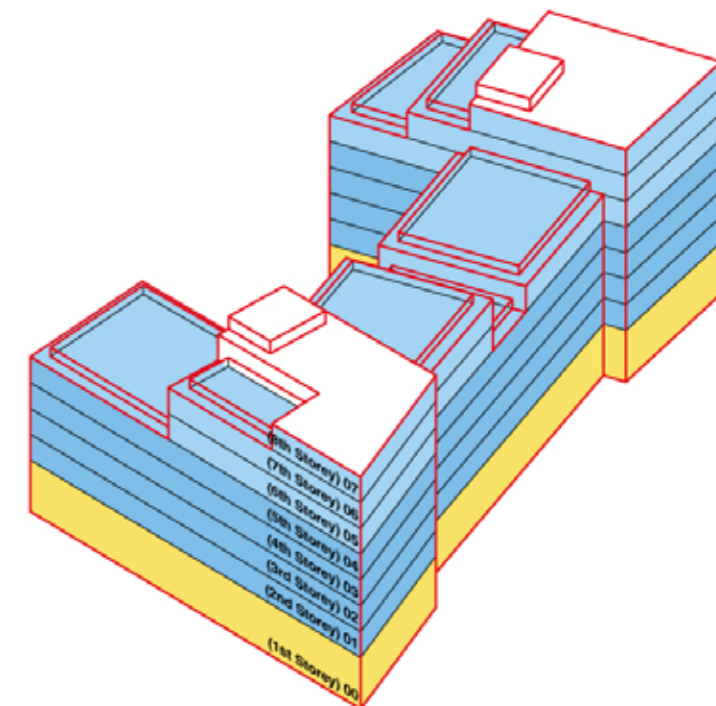

Figure 6.491 Plot E1 Indicative massing set up within maximum plot parameters

6. Plot Guide

6.7 Plot E1

6.7.6 Top of the Building

E1 TOP OF THE BUILDING - ROOF PROFILES

The general approach to E1 is to have set back and pitched roof treatments with inhabitation options to reduce the perceived building height. Variation to the overall roofscape should provide shelter to inhabited terrace spaces.

6.7.6.1 - Inhabited pitched and mansard with dormer roof elements should be incorporated and include sheltered greenspaces and terraces. See figures 6.493, 6.494, 6.496 and 6.497 on opposite page.

6.7.6.2 - Accessible terrace zones must be provided and should be set back from the façade by a minimum of 1.5m and have an upstand of minimum 1.1m. See figures 6.493, 6.494 and 6.495 on the opposite page.

6.7.6.3 - Perimeter and setback upstands for shelter and guarding should be provided to all accessible roofs.



Figure 6.492 Plot E1 Rooftop setback plan

Legend

- Maximum plot parameters
- Indicative suggested massing
- Accessible flat roof terrace
- Non-accessible roof
- - - - - Indicatively placed Technical/Plant Zones
- - - - - Indicative Core Positions

6. Plot Guide

6.7 Plot E1

6.7.6 Top of the Building

E1 TOP OF THE BUILDING - ROOF PROFILES CONTINUED

The general approach to E1 is to have set back and pitched roof treatments with inhabitation options to reduce the perceived building height. Variation to the overall roofscape should provide shelter to inhabited terrace spaces.

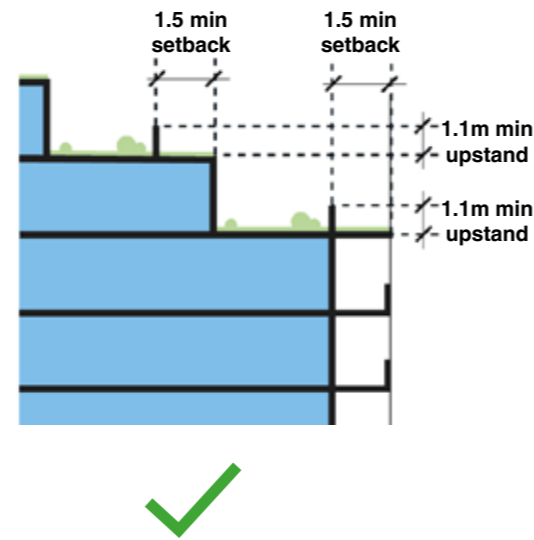

Figure 6.493 Single storey mansard roof with plant setback

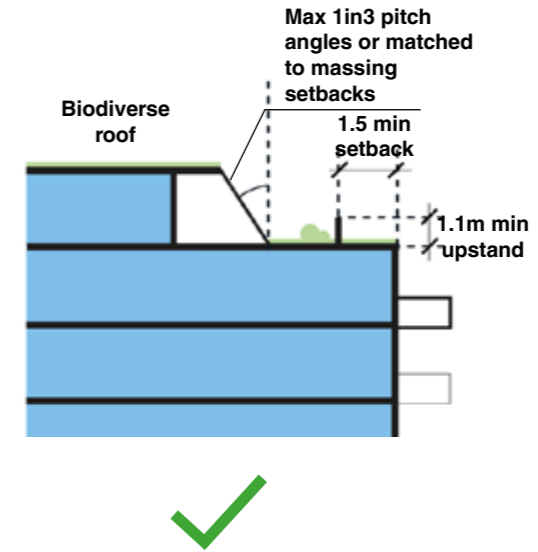

Figure 6.494 Single storey mansard roof

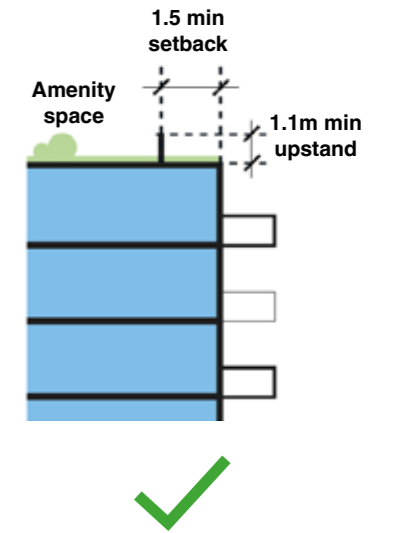

Figure 6.495 Upstand to 1.1m height and a 1.5m min setback

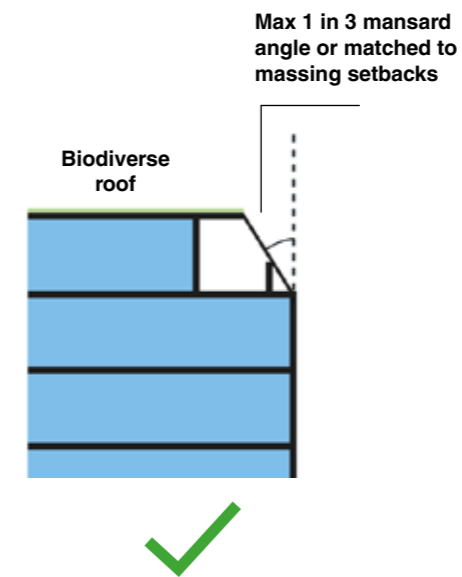

Figure 6.496 Single storey inhabited mansard roof

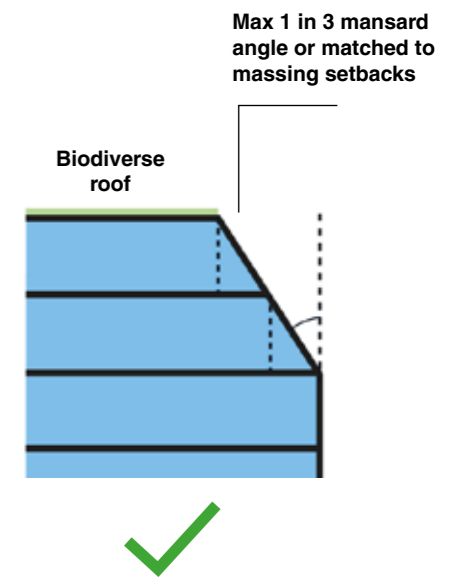

Figure 6.497 Two storey mansard roof option

6. Plot Guide

6.7 Plot E1

6.7.6 Top of the Building

E1 TOP OF THE BUILDING - ROOF TECHNICAL ZONE

A maximum AOD has been established for Plot E1. The maximum AOD steps down towards the west as well as the centre of the plot, providing variance in the massing.

Where not designated for accessible roof zones, a technical/plant zone exists that encompasses the maximum extents for any final arrangements of required plant.

All core positions, both full storey lobbied roof access extensions or nominal overruns, are shown indicatively.

6.7.6.4 - Any plant must be located within the technical zone and set back a minimum 3m from the façade line with a maximum 3m high enclosure.

6.7.6.5 - Green or brown roofs should be provided to all non accessible roof areas.

6.7.6.6 - Where plant and technical zones cannot be setback 3m or aligns with the façade edge a façade upstand should be used of a maximum height of 3m.

6.7.6.7 - All core positions, both full storey lobbied access extensions or nominal overruns should be located within the technical zones.



Figure 6.498 Plot E1 Maximum extents and setback roof plan

Legend

- Maximum plot parameters
- Indicative suggested massing
- Set back zone for technical/plant areas (no plant in these areas)
- Maximum extents available for potential technical/plant zone
- Indicatively placed technical/plant zones
- Indicative core positions

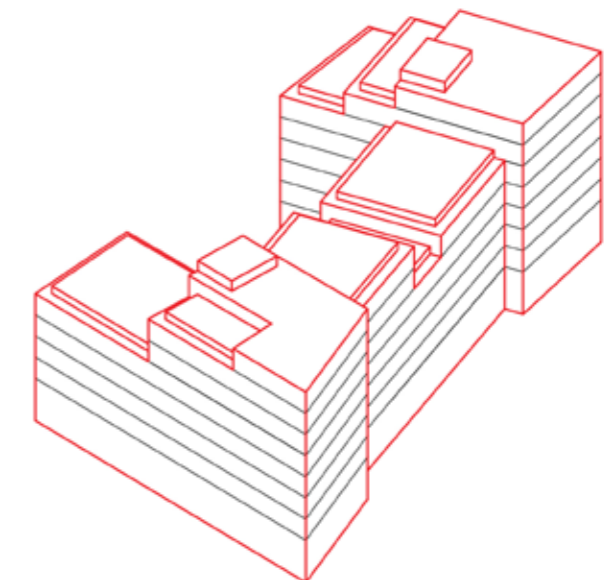

Figure 6.499 Plot E1 Available technical zones within maximum plot parameters

6. Plot Guide

6.7 Plot E1

6.7.7 Middle of Building

The overall approach is to create an elegant, high quality building. The façades should provide a strong frontage, contributing to the identity of the development. The materials palette proposed includes natural and re-constituted stone and high quality pre-cast concrete (see chapter 6.8.13 Material Appearance).

The urban analysis suggests (DAS - 5.8 Approach to Architecture) the façades should have a varied and characterful mix of frontages to surround and enliven the square.

A regular sub-grid should be set-up to coordinate the rhythm of the windows and balconies. Balcony solutions should complement any desired façade subdivision with further variation via the use of inset, juliet and proud balconies.

6.7.7.1 - All elevations must respond appropriately to their setting and their expression should complement the architectural language of Plots D1, E2, E3 and the IFC buildings opposite.

6.7.7.2 - The elevations should respond appropriately to their setting and their expression should follow the architectural language of the Neighbourhoods typology.

6.7.7.3 - There must be depth and layering in the articulation of the façades to provide a sense of quality.

6.7.7.4 - Designers should follow the glazing percentage per façade as set out in the Chapter 5.17 Windows.

6.7.7.5 - Window layouts should follow overall gridded arrangements. Windows can be amalgamated into double storey windows and/or with double storey expressed frames.

6.7.7.6 - The architectural language of the façades should continue to ground level to allow for the incorporation of duplex units. See figure 6.516.

6.7.7.7 - Corner features including balconies and chamfers should be considered as part of the building design.

6.7.7.8 - The architectural language should use a blend of punched and expressed windows with frame reveals and full height windows and infill to expressed structural frame to all elevations. This is to create frontage proportion and subdivision to the elevation. See figure 6.501.

6.7.7.9 - Architectural details should consider devices that include but not limited to shadow gaps and joint lines to express the unit divisions and rhythms.

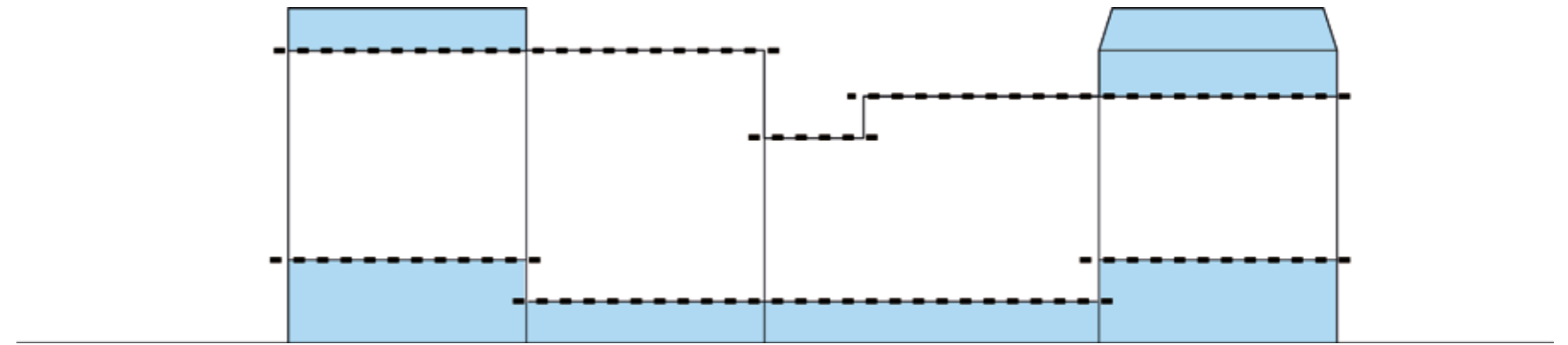

Figure 6.500 Plot E1 eastern elevation - top, middle, bottom

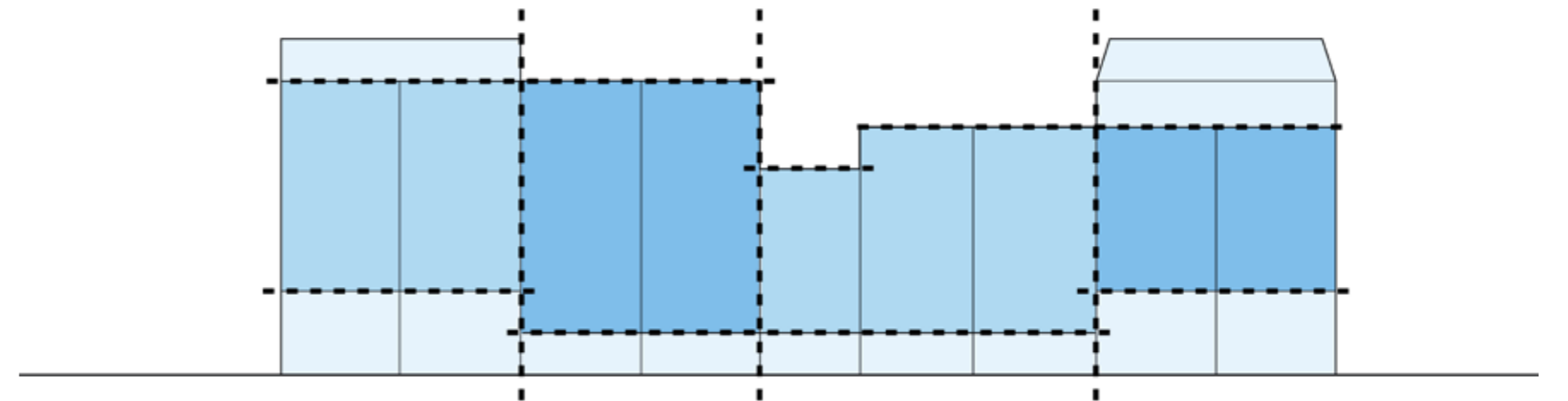

Figure 6.501 Plot E1 eastern elevation - frontage proportion and subdivision

6. Plot Guide

6.7 Plot E1

6.7.8 Bottom of Building

There may be a number of entrances required on this building including one or more commercial/leisure entrances and secondary entrances that include fire escape and/or service entrance(s).

All entrances should be carefully integrated into the façade and should be coherent with the façade material expression.

6.7.8.1 - A minimum of two residential entrance and associated lobby are to be provided within the zones identified. See figure 6.502.

6.7.8.2 - Non residential uses should have their own dedicated entrances.

6.7.8.3 - Entrances must be clearly legible through articulation and design and must have a high quality appearance.

6.7.8.4 - All entrances must be carefully integrated into the massing of the building.

6.7.8.5 - Nominally set back ground façade conditions should exist across plot E1. See figure 6.504.

6.7.8.6 - The bottom of the building must have a strong architectural expression (see Chapter 5.16 Bottom of building).

6.7.8.7 - Additional openings should be provided if required at ground level to La Route de La Libération.

6.7.8.8 - Plot E1 must have additional height at ground level to allow for the incorporation of residential duplex units as shown in figure 6.503.

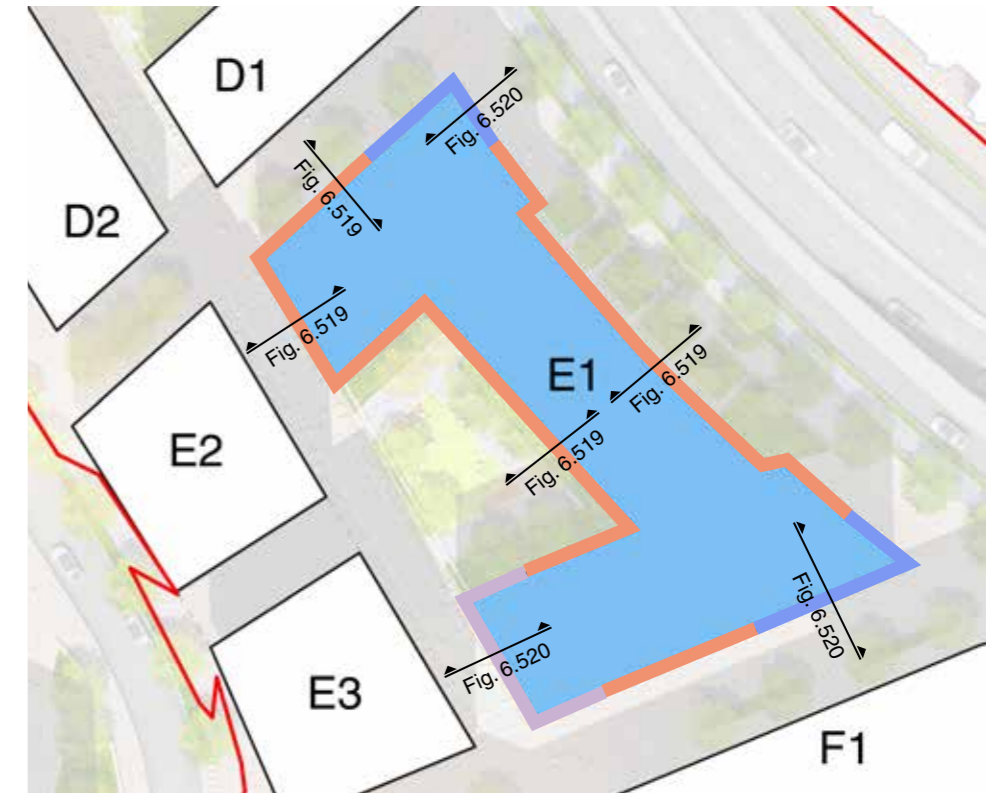

Legend

- Zone for retail entrances
- Zone for residential entrances
- Zone for social infrastructure entrances

Figure 6.502 Plot E1 bottom of building suggested condition

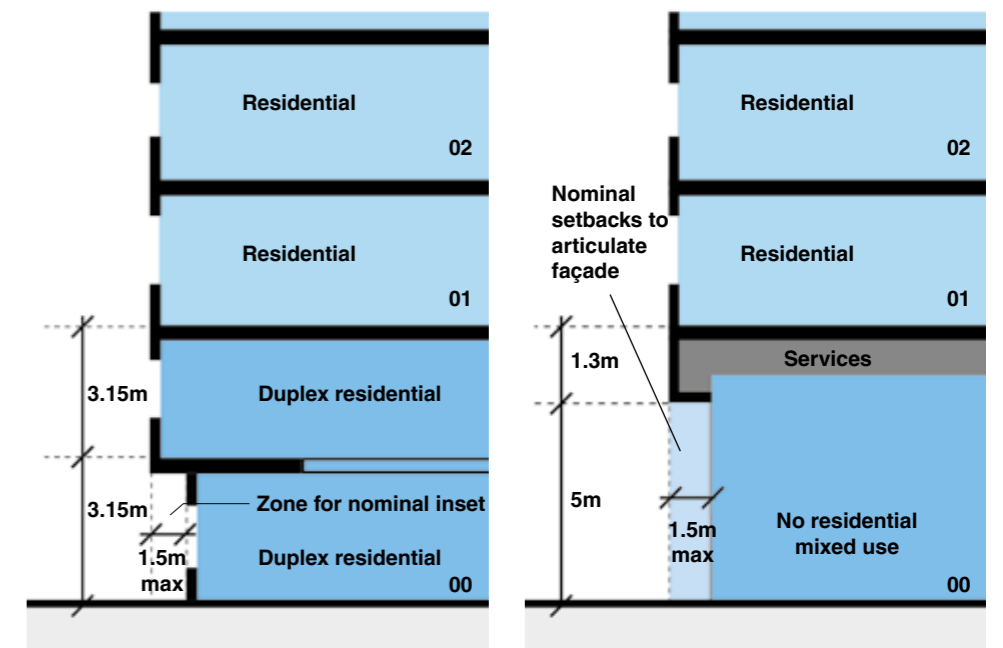

Figure 6.503 Duplex residential condition

Figure 6.504 Up to 1.5m nominal setback condition

6. Plot Guide

6.7 Plot E1

6.7.8 Bottom of Building

The plot is on a gradient. The location of the entrances at ground floor level should take into account any variance in external levels. There should be visual interest and a variety of type and colour to the retail and commercial frontages. The design of the frontages should be complementary to the architectural typology and draw upon the existing St Helier street-scape for inspiration.

6.7.8.9 - Entrances must have level access even where a change in level occurs.

6.7.8.10 - The floor to floor height at ground floor varies to provide level access to the residential and non-residential entrances and must be a maximum of 6.3m.

6.7.8.11 - Plot E1 should provide ground level retail and residential uses (see chapter 4.1.3 Use Distribution).

6.7.8.12 - Retail frontages should be complementary with the overall material palette of the typology. A variety of materials and colours should provide architectural accents and highlights to frontages. See figure 6.506.

6.7.8.13 - Residential lobbies are to be set in from street line with mainly glazed frontages. Where required residential entrance lobbies should have either integrated revolving doors or wind lobbies. See figure 6.507.

6.7.8.14 - Entrances to duplexes should be provided with direct access to the street and integrated into the bottom of the building as figure 6.505.

Legend

- Zone for material variance and signage
- Zones for portal/inset framing detail
- Zone for glazed entrance
- Inset of nominal depth
- A** Glazed entrance with no bays (e.g. Retail use)
- B** Glazed entrance with double or single bay (double shown) for typical retail entrances
- C+D** Wind lobby (C) or integrated revolving door (D) arrangements for residential lobbies

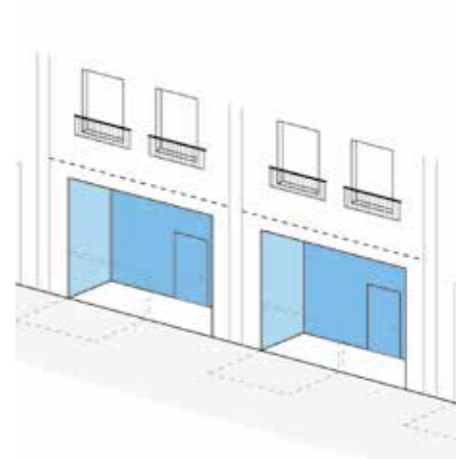

Figure 6.505 Illustrative example of a protected residential duplex entrance

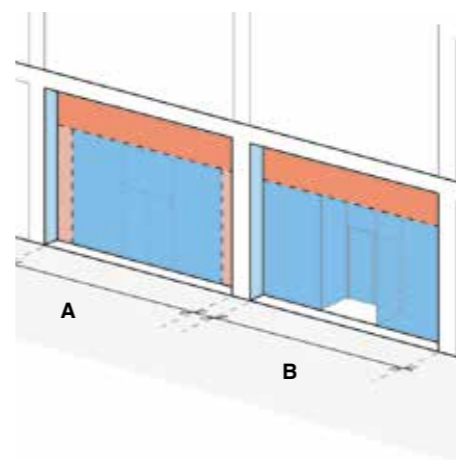

Figure 6.506 Illustrative example of non-bayed and bayed retail entrances

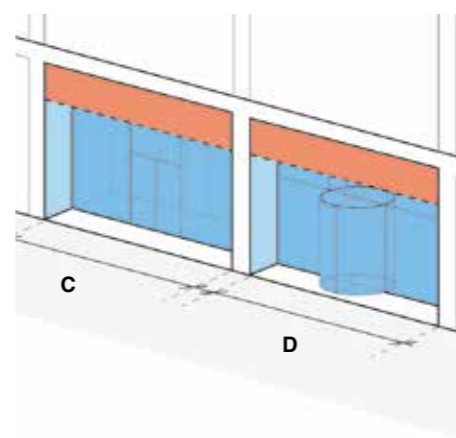

Figure 6.507 Illustrative example of wind lobbies or revolving doors at building entrances

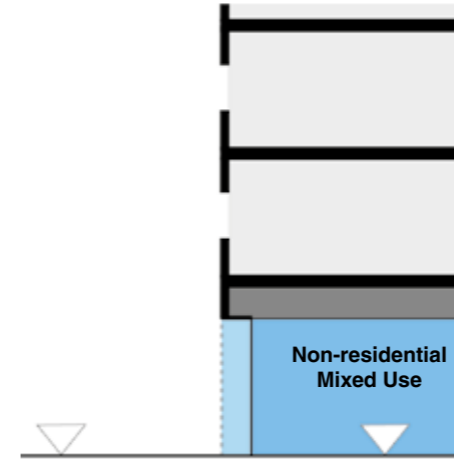

Figure 6.508 All primary entrances to have level access



Figure 6.509 Example of seating integrated into retail frontages



Figure 6.510 Example of awnings to retail



Figure 6.511 Illustrative duplex residential entrance to street



Figure 6.512 Double bay retail frontages suggested to link to typical Jersey vernacular types

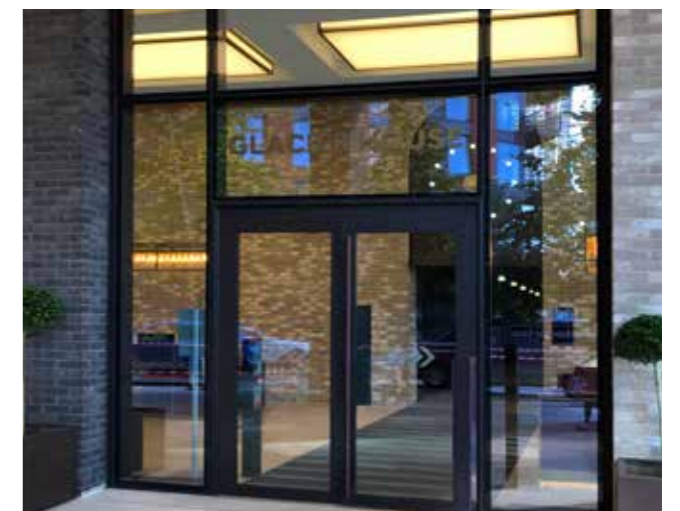

Figure 6.513 Example of a glazed residential lobby entrance

6. Plot Guide

6.7 Plot E1

6.7.9 Adjacent Buildings

E1 BUILDING ADJACENCIES

Plot E1 is located within close proximity to plots D1 and E2, E3 and F1.

6.7.9.1 - Consideration for balcony placement and openings should be taken to minimise proximity issues where façades face onto closely adjacent plots such as E1 and D2. See also section 6.7.10 and 6.7.11.

6.7.9.2 - Consideration of window placement and directional framing should be taken where plots are directly adjacent to one another to minimise overlooking. See chapter 5.18 Proximity and Overlooking.



Figure 6.514 Plot E1 Building adjacencies key plan



Figure 6.515 Plot E1 Building adjacencies key plan

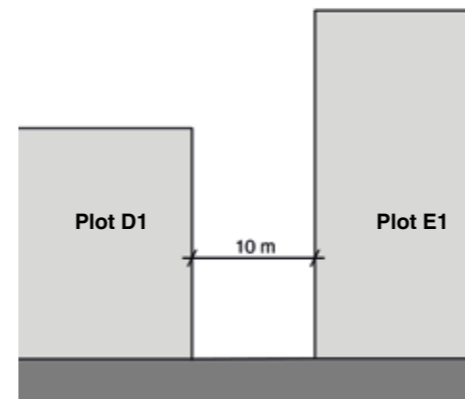

Figure 6.516 Building adjacency between D1 and E1

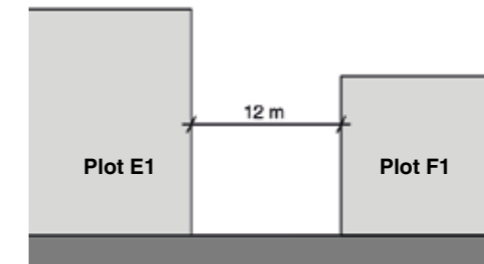

Figure 6.517 Building adjacency between E1 and F1

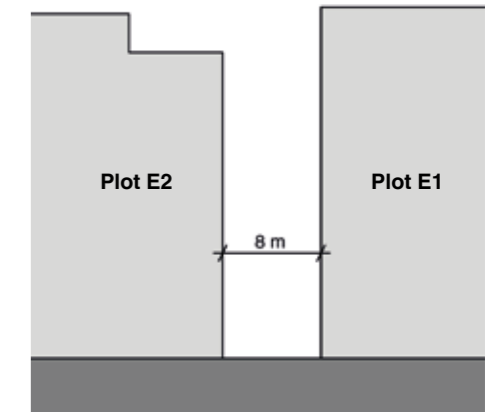

Figure 6.518 Building adjacency between E2 and E1

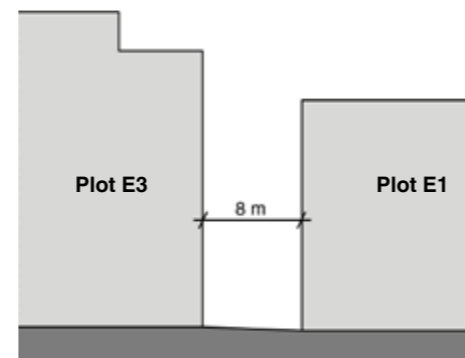

Figure 6.519 Building adjacency between E3 and E1

6. Plot Guide

6.7 Plot E1

6.7.10 Openings

E1 OPENINGS IN THE FAÇADE

Designers should pay careful attention to the placement of openings across the façade. Whilst different opening compositions should be considered, they should also be as part of a coherent façade design strategy.

6.7.10.1 - Windows should form consistent patterns across the façade, but allow for variation within the overall grid. See figures 6.520 and 6.521.

6.7.10.2 - Dormers should feature where mansard roofs are used. See figures 6.522 and 6.523.

6.7.10.3 - Inhabited sections of pitched or mansard roof should be used to create semi enclosed and sheltered terrace spaces within plot E1. See figures 6.524 and 6.525.

6.7.10.4 - Upstands and setback upstands should be used as part of the wind mitigation strategy to provide shelter for rooftop amenity spaces.

6.7.10.5 - All façades should have a considered level of detail to the window openings - depth, reveals and framing, to give a high quality layered result.

6.7.10.6 - Areas for building services should be treated as screened openings (e.g. Louvres/ventilation grills), for a coherent elevation strategy. These should be minimised on principal elevations wherever possible.

6.7.10.7 - Consideration for access for the cleaning, maintenance and potential replacement of window elements should be incorporated into the design.

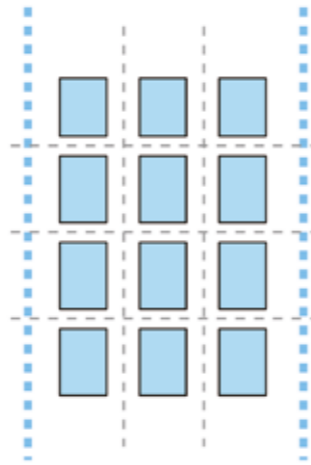

Figure 6.520 Gridded window layout

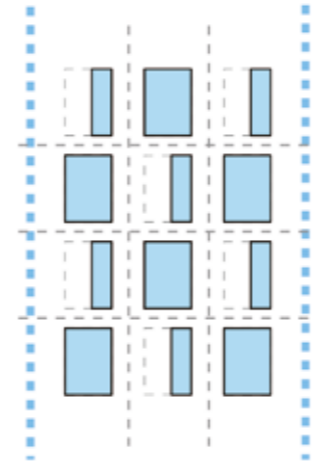

Figure 6.521 Gridded window layout with slipped windows



Figure 6.522 Double mansard windows

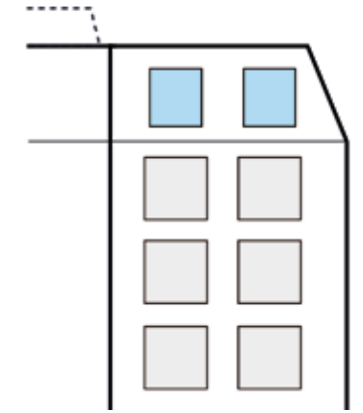

Figure 6.523 Single mansard windows



Figure 6.524 Double mansard/pitched inhabited roof



Figure 6.525 Single mansard/pitched inhabited roof

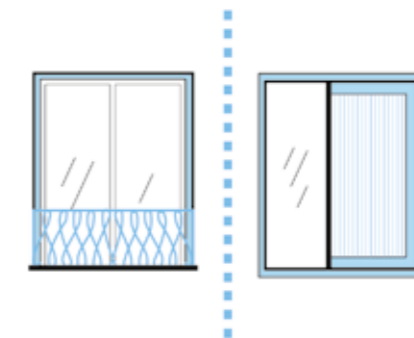

Figure 6.526 Variation in window detail

6. Plot Guide

6.7 Plot E1

6.7.11 Balconies

E1 BALCONY CONDITIONS

The balcony arrangement should be carefully positioned as part of the overall composition of the façade.

Consideration of the balcony location should be taken into account in order to avoid overlooking and proximity issues.

Consideration of the balcony location within the façade should be taken into account to avoid unnecessary shading to the rooms below.

It is suggested that the overall predominant balcony be proud balconies and inset with juliet balconies used for façade variation e.g. 40% proud, 40% inset and 20% juliet where proximity allows. Elsewhere it is suggested that there is a façade variation of 70% inset - 30% juliet.

6.7.11.1 - Inset, projecting and juliet balconies are permitted.

6.7.11.2 - Proud balconies are not permitted where proximity prohibits, see Chapter 5.18 Proximity and Overlooking for further guidance.

6.7.11.3 - Balustrades can vary in design but must be complementary to the façade design.

6.7.11.4 - A minimum balustrade height of 1.1m must be provided for all balconies.

6.7.11.5 - Horizontally barred balustrades are not permitted as they are a climbing hazard.

6.7.11.6 - There should be variation in colour and material of balustrading as well as specific highlighting materials to the returns and soffits of any inset balconies for visual interest and variation across façades.

6.7.11.7 - Corner balconies should be integrated into the façade with indicated on figure 6.527.

6.7.11.8 - Proud balconies should start at the first typical residential floor.



Figure 6.527 Plot E1 balcony condition key plan

Legend

- - - Building boundary
- Inset, juliet and proud balconies
- Inset and juliet balconies
- Inset corner balcony

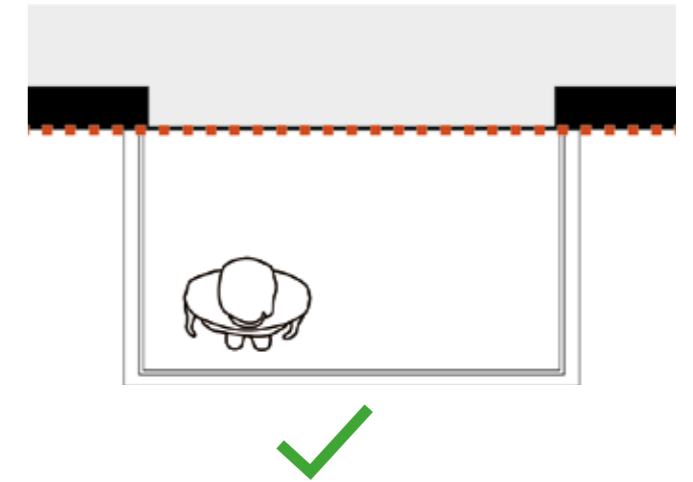

Figure 6.528 Proud balcony condition

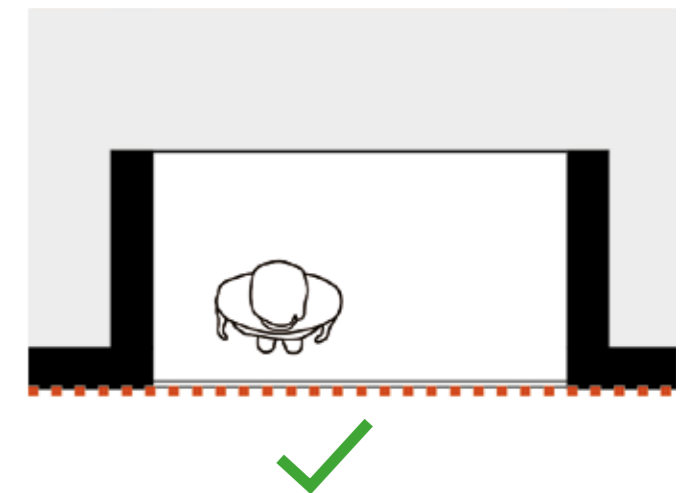

Figure 6.529 Inset balcony condition

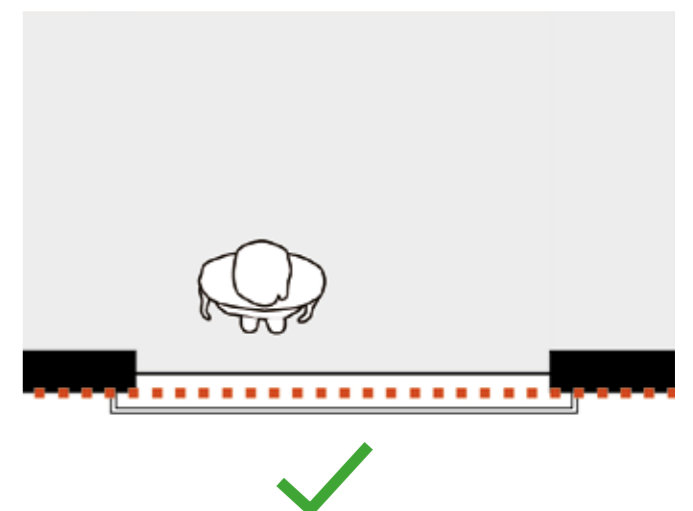

Figure 6.530 Juliet balcony condition

6. Plot Guide

6.7 Plot E1

6.7.12 Material Appearance

Hard-wearing and long-life quality materials should be selected. This should take inspiration from the existing local façade colours, textures and materials and new or complementary material types can be introduced where appropriate.

Care should be taken when sourcing all materials to ensure minimum environmental impact and the sustainable credentials of the source and the materials lifecycle, see Chapter 6.9 of SWSH Visioning Framework Sustainability Statement for further guidance.

The inner courtyards to the residential neighbourhoods form a series of more informal, human scale experiences along the lane way characterised by community gardens and a finer grain to the architectural detailing and use of materials. This is in contrast to the more robust, formal elevational treatments to the outward facing elevations of the residential neighbourhoods that form the edges to major streets and routes.

The primary material palette for the façade of the E1 Neighbourhoods typology should be drawn from both the St Helier local stone types as full stone clad items in conjunction with a mix of re-constituted stone 'frame and infill' approaches.

The secondary material palette for areas of roof of Plot E1 could include various 'infill' material options to add life, vibrancy and character to the residential neighbourhoods.

The tertiary material palette for all framing, detailing and areas of variation or highlight within inset infill zones, balconies, balustrades and openings across façades of Plot E1 could include an expanded palette of metals including wood, terracotta, glazed brick/tile and ceramic elements, with associated pattern and texture/relief options for further interest.

6.7.12.1 - Warm and restrained natural tones of stone should be considered in particular local, or equivalent granites, limestones, and equivalent reconstituted stones in a similar tone where a building is completely stone clad.

6.7.12.2 - Warm and restrained natural tones of stone, reconstituted stones and concretes should be used for the overall enclosure or 'frame' where a building is utilising the 'frame and infill' approach.

6.7.12.3 - Material selection should consider material used on neighbouring plot façades.

6.7.12.4 - Material selection should be responsive to the neighbouring IFC buildings

6.7.12.5 - Materials palette used in the inner courtyards should use a finer grain of architectural detailing to create 'softer' approach as set in the Neighbourhoods typology.

6.7.12.6 - Promotion of the use of materials that incorporate recycled content and procuring products with a low environmental impact should be a priority when choosing materials. For further guidance see Chapter 6.9 of SWSH Visioning Framework Sustainability Statement.

6.7.12.7 - The secondary material palette should be complementary to the primary composition.

6.7.12.8 - The materials palette for areas of façade that extend to form roof upstands should either be formed from the primary palette or include various 'infill' material options to add life, vibrancy and character.

6.7.12.9 - The tertiary material palette should be complementary to the primary and secondary composition.

6.7.12.10 - Exuberant and varied palettes of materials should be used as the tertiary palette to introduce patterning, texturing and finer detail.

6.7.12.11 - All materials should be hard wearing and suitable for a marine environment.

6.7.12.12 - Colours for the window frames, door frames, balcony metalwork and other architectural and design features must be complementary to the materials used on the rest of the building.

PRIMARY PALETTE



Figure 6.531 Limestones



Figure 6.532 Re-constituted Stone



Figure 6.533 Granites

SECONDARY AND TERTIARY PALETTES



Figure 6.535 Concrete, light brick as well as GRCs and metals

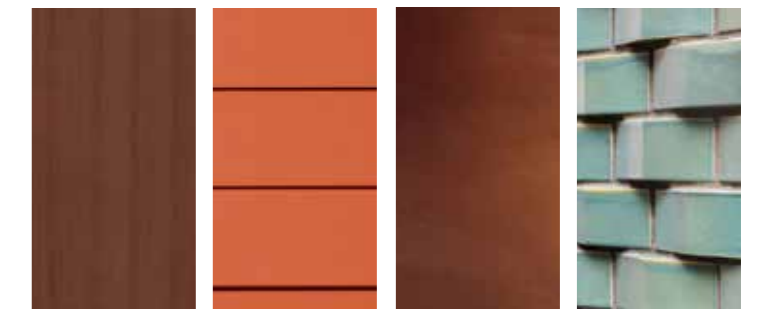

Figure 6.536 Acetylated or equivalent woods, terracotta, pre-oxidised and/or sealed/coated pre-weathered metals and glazed brick/tiles

This Page is Left Intentionally Blank

6. Plot Guide

6.8 Plot E2

6.8.1 Overview

PLOT OVERVIEW

Plot E2 is located in the southern part of the site and is part of the Neighbourhoods typology as described in Chapter 5.9 - Architectural Typologies. It is a 'Square' shaped building which, in conjunction with plot E3, encloses a semi private communal courtyard of E1. It has a key western elevation on Rue de L'etau.

6.8.1.1 - The use for plot E2 should include residential use on all floors.

6.8.1.2 - The maximum plot parameter diagrams identify the maximum extent permissible of the building and should be read with the parameter plans see figures 6.556 and 6.557.

6.8.1.3 - Plot E2 should allow for duplex units at ground level.

6.8.1.4 - All building elements with the exception of projecting balconies must be designed within the maximum plot parameters.

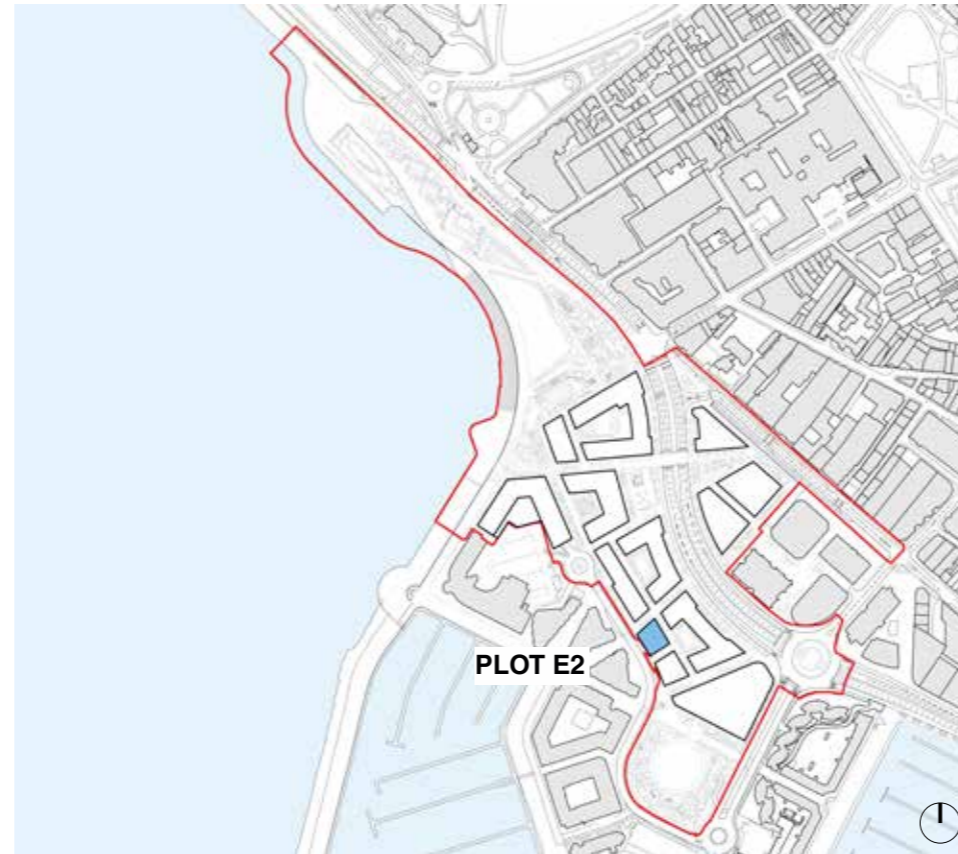

Figure 6.538 Plot parameters key plan

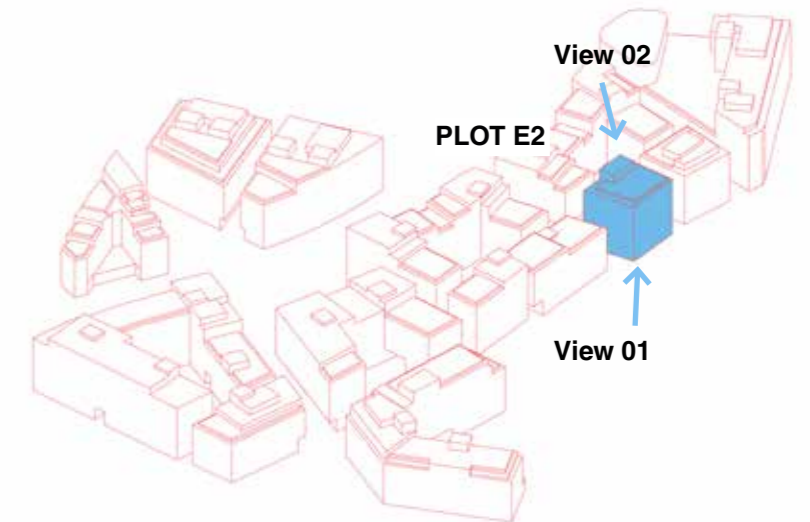

Figure 6.539 Plot parameters key diagram

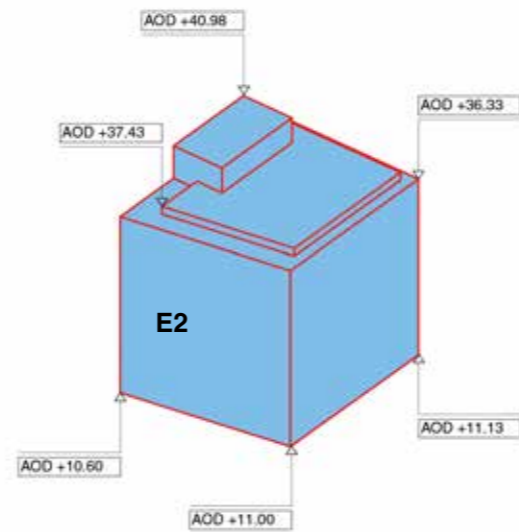

Figure 6.540 Maximum plot parameters diagram - View 01

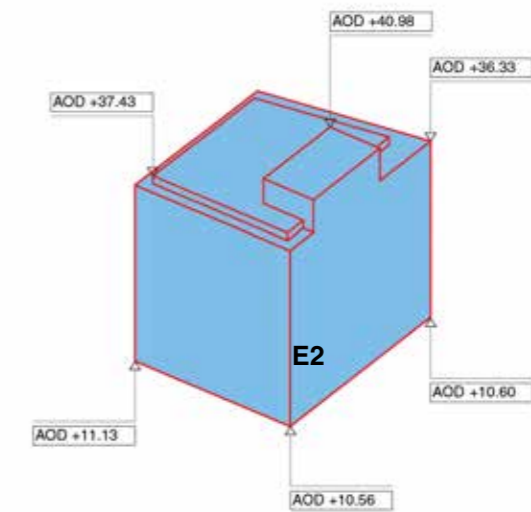

Figure 6.541 Maximum plot parameters diagram - View 02

6. Plot Guide

6.8 Plot E2

6.8.2 Plot Overview

Plot E2 is part of the Neighbourhood typology, with a calm 'neighbourhood' feel designed to support a new community of waterfront residents keen to live, work and play in St Helier and well supported by local shops and community provision.

Figure 6.558 demonstrates how plot E2 is located within the illustrative landscape framework, and provides key plot dimensions.

For further details on dimensions of key routes and codes relating to Plot E2's relationship with the public realm please refer to Chapter 4 - Prescription of Future of Development - Public Realm and Open Space, of this document set.



Figure 6.542 Ground floor plan

Legend

 Plot E2

 Adjacent Plots

6. Plot Guide

6.8 Plot E2

6.8.3 General Appearance

The analysis in Chapter - 5.8 Approach to Architecture in the design and access statement indicates the plot should respond in scale and façade articulation to the adjacent character areas. The overall approach is to create a high quality building with a distinct frontage that contributes to the identity of the residential neighbourhoods.

The architectural language of each façade should be consistent although the composition may vary to respond to specific considerations e.g. proximity to neighbouring plots and daylight/sunlight.

6.8.3.1 - The elevations should respond appropriately to their setting and their expression should complement the architectural language of plots D2, E1 and E3. They should also respect the character of the Horizon buildings along Rue de L'etau.

6.8.3.2 - Plot E2 is part of the Neighbourhoods typology. All elevations should respect their typology and should also consider the character of the buildings opposite Rue de L'etau.

6.8.3.3 - Windows should have deep reveals to provide adequate depth to the façade.

6.8.3.4 - The building envelope must define a clear bottom, middle and top through the architectural expression and treatment of the façade. See figure 6.559.

6.8.3.5 - Consideration must be given to how duplex units are integrated into the building at ground floor level

6.8.3.6 - There must be depth and layering in the articulation of the façades to provide a sense of quality.

6.8.3.7 - The architectural language should use full height windows and infill to expressed structural frame to all elevations.

6.8.3.8 - Variations in depth, height and materials should be used to break down the horizontal elevation into distinct vertical proportions. See figure 6.544.

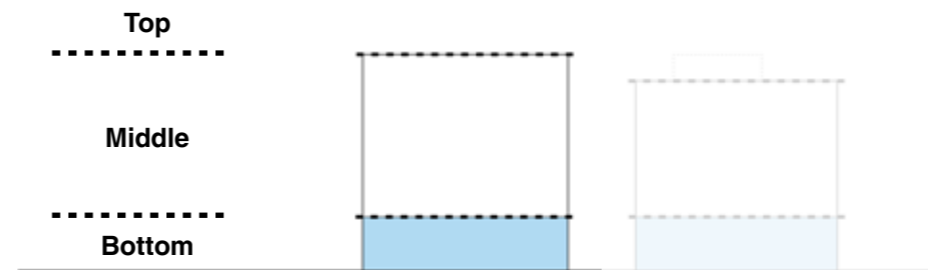

Figure 6.543 Plot E2 - The Neighbourhoods reference elevation top, middle and bottom clearly defined by ground and roof treatments

6. Plot Guide

6.8 Plot E2

6.8.4 Wind mitigation

The impact of wind on the public and private realm environment should be mitigated by the incorporation of design features highlighted in the SWSH Visioning Framework Wind and Microclimate Assessment.

6.8.4.1 - Rooftop balustrades and set backs must be considered as indicated in section 6.9.6 - Top of the Building.

6.8.4.2 - Corner inset balconies must be considered as indicated in the section 6.9.11 - Balconies and figure 6.562 opposite.

6.8.4.3 - Wind mitigation solutions should be complementary to overall architectural typology design and integrated into the building design.

6.8.4.4 - The design of plot E2 must incorporate wind mitigation measures as identified in the wind chapter of the EIS, or alternative equivalent measures to achieve the same mitigation effect developed and tested through detailed design.

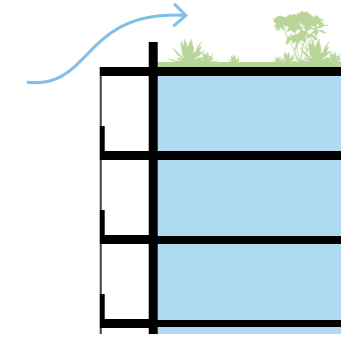

Figure 6.545 Upstand for wind mitigation

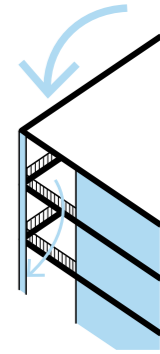

Figure 6.546 Inset balconies on corners for wind mitigation



Figure 6.547 Example of upstand



Figure 6.548 Example of inset balconies

6. Plot Guide

6.8 Plot E2

6.8.5 Massing

A maximum AOD has been established for Plot E2. The maximum AOD allows for lobby access to the rooftop amenity space.

Within these maximum extents upstands should be used to enclose amenity space on the roof as a wind mitigation device.

6.8.5.1 - The ground floor should have additional height to accommodate residential duplex use. See figure 6.549 below.

6.8.5.2 - The maximum number of storeys permissible for Plot E2 is 7 storeys (ground plus 6). See figure 6.551 for indicative floor to floor setting out.

6.8.5.3 - Figure 6.550 identifies the maximum shoulder heights permissible.

6.8.5.4 - Balustrades and privacy screens may project above the shoulder height provided they are contained within the accessible terrace zone as indicated in figure 6.567.

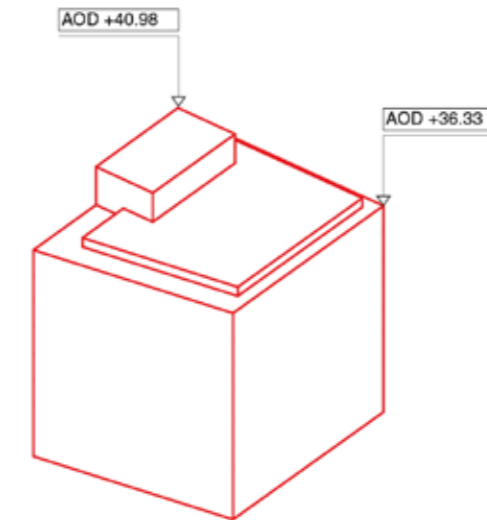

Figure 6.550 Plot E2 Maximum plot parameters showing shoulder heights

Legend

- Maximum plot parameters
- +6.3m floor to floor bottom zone
- Indicative shaped massing where applicable
- Suggested roof treatment & accessible terrace zones

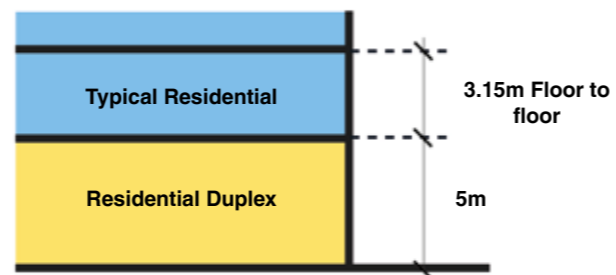

Figure 6.549 Typical floor to floor

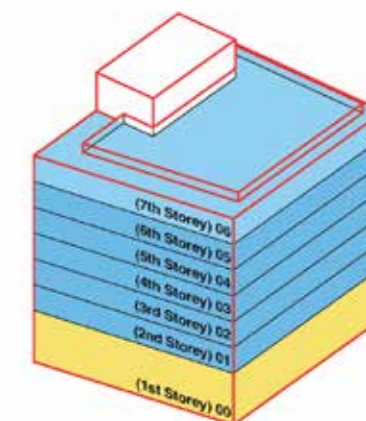

Figure 6.551 Plot E2 Indicative massing set up within maximum plot parameters

6. Plot Guide

6.8 Plot E2

6.8.6 Top of the Building

E2 TOP OF THE BUILDING - ROOF PROFILES

General approach to E2 is to have set back upstands to maintain perceived building height.

6.8.6.1 - Accessible terrace zones must be provided and should be set back from the façade by a minimum of 1.5m and have an upstand of minimum 1.1m. See figures 6.553, 6.554 and 6.555.

6.8.6.2 - Where the accessible roof terrace is directly adjacent to the plant technical zone, the design of the plant enclosure should be considered.

6.8.6.3 - Perimeter and setback upstands for shelter and guarding should be provided to all accessible roofs.



Figure 6.552 Plot E2 Rooftop setback plan

Legend

- Maximum plot parameters
- Indicative suggested massing
- Accessible flat roof terrace
- Non-accessible roof
- Indicatively placed Technical/Plant Zones
- Indicative Core Positions

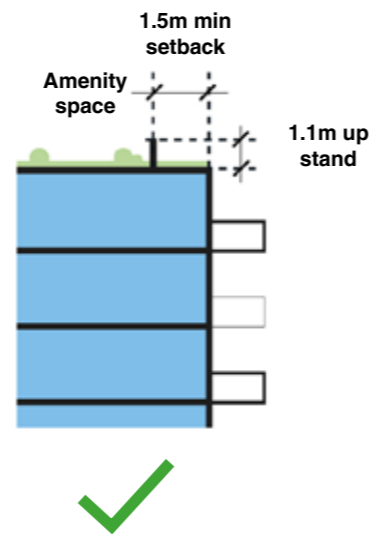

Figure 6.553 Upstand to 1.1m min height and a 1.5m min setback

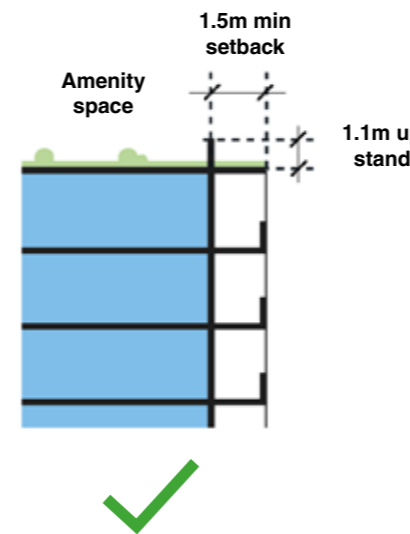

Figure 6.554 Upstand to 1.1m min height and a 1.5m min setback

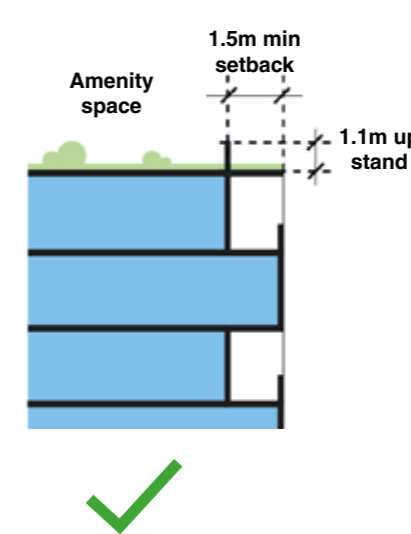

Figure 6.555 Upstand to 1.1m min and a 1.5m min setback

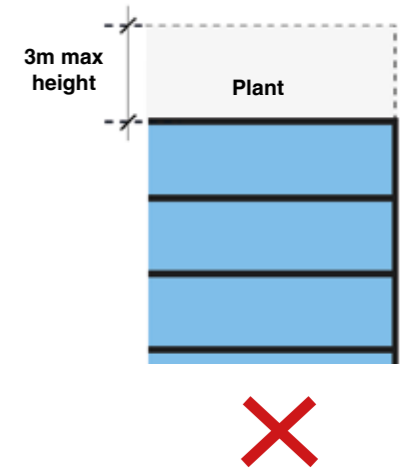

Figure 6.556 No flat roofs or plant

6. Plot Guide

6.8 Plot E2

6.8.6 Top of the Building

E2 TOP OF THE BUILDING - ROOF TECHNICAL ZONE

A maximum AOD has been established for Plot E2. The maximum AOD allows for lobby access to the rooftop amenity space.

Where not designated for accessible roof zones, a technical/plant zone exists that encompasses the maximum extents for any final arrangements of required plant.

All core positions, both full storey lobbied roof access extensions or nominal overruns, are shown indicatively.

6.8.6.4 - Core positions must be located within the technical zone and set back a minimum of 1.5m from the façade line with a 1.1m high upstand. See figure 6.554 on previous page.

6.8.6.5 - Green or brown roofs should be provided to all non accessible roof areas.

6.8.6.6 - Any plant should not align directly to the perimeter of the façade. See figure 6.572 on the previous page.

6.8.6.7 - Where core, plant and technical zones cannot be setback 3m or aligns with the façade edge a façade upstand should be used of a maximum height of 3m.

6.8.6.8 - All core positions, both full storey lobbied access extensions or nominal overruns should be located within the technical zones.



Figure 6.557 Plot E2 Maximum extents and setback roof plan

Legend

- Maximum plot parameters
- Indicative suggested massing
- Set back zone for technical/plant areas (no plant in these areas)
- Maximum extents available for potential technical/plant zone
- Indicatively placed technical/plant zones
- Indicative core positions

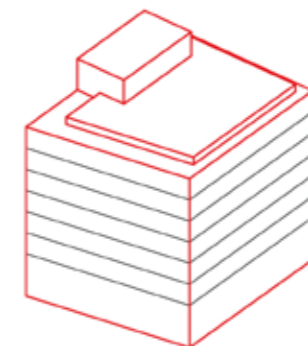

Figure 6.558 Plot E2 Available technical zones within maximum plot parameters

6. Plot Guide

6.8 Plot E2

6.8.7 Middle of Building

The overall approach is to create an elegant, high quality building. The façades should provide a strong frontage, contributing to the identity of the development. The materials palette proposed includes natural and re-constituted stone and high quality pre-cast concrete (see section 6.9.13 Material Appearance).

The urban analysis suggests (DAS - 5.8 Approach to Architecture) the façades should have a varied and characterful mix of frontages around the residential neighbourhoods.

A regular sub-grid should be set-up to coordinate the rhythm of the windows and balconies. Balcony positions should complement any desired façade subdivision with further variation via the use of inset, juliet and proud balconies.

6.8.7.1 - All elevations must respond appropriately to their setting and their expression should complement the architectural language of Plots D2, E1, E3 and the Horizon buildings opposite.

6.8.7.2 - The elevations should respond appropriately to their setting and their expression should follow the architectural language of the Neighbourhoods typology.

6.8.7.3 - There must be depth and layering in the articulation of the façades to provide a sense of quality.

6.8.7.4 - Designers should follow the glazing percentage per façade as set out in the Chapter 5.17 Windows.

6.8.7.5 - Window layouts should follow overall gridded arrangements.

6.8.7.6 - The architectural language of the façades should continue to ground level to allow for the incorporation of duplex units. See figure 6.560.

6.8.7.7 - Corner features including balconies should be considered as part of the building design.

6.8.7.8 - The architectural language should use full height windows and infill to expressed structural frame to all elevations. This is to create frontage proportion and subdivision to the elevation.

6.8.7.9 - Architectural details should consider devices that include but not limited to shadow gaps and joint lines to express the unit divisions and rhythms.

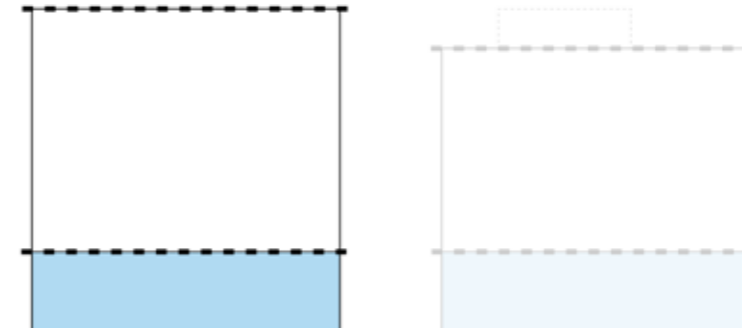

Figure 6.559 Plot E2 Elevation - top, middle, bottom

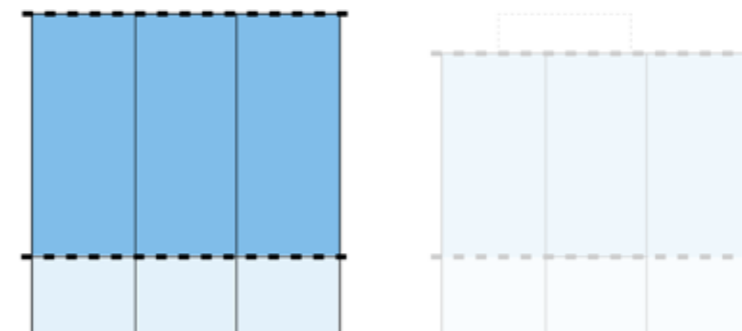

Figure 6.560 Plot E2 Elevation - frontage proportion and subdivision

6. Plot Guide

6.8 Plot E2

6.8.8 Bottom of Building

There may be a number of entrances required on this building that include fire escape and/or service entrance(s).

All entrances should be carefully integrated into the façade and should be coherent with the façade material expression.

6.8.8.1 - A minimum of one residential entrance and associated lobby are to be provided within the zones identified. See figure 6.561.

6.8.8.2 - Entrances must be clearly legible through articulation and design and must have a high quality appearance.

6.8.8.3 - All entrances must be carefully integrated into the massing of the building.

6.8.8.4 - The bottom of the building must have a strong architectural expression (see Chapter 5.16 Bottom of building).

6.8.8.5 - Plot E2 must have additional height at ground level to allow for the incorporation of residential duplex units as shown in figure 6.562.

Legend

 Zone for residential entrances



Figure 6.561 Plot E2 bottom of building suggested condition

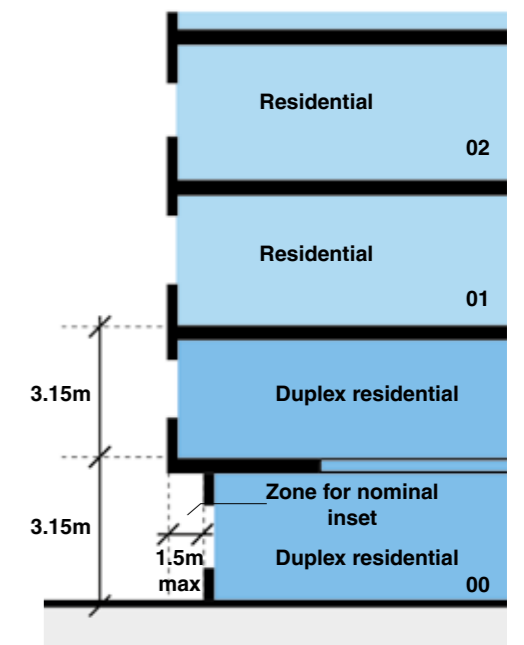

Figure 6.562 Duplex residential condition

6. Plot Guide

6.8 Plot E2

6.8.8 Bottom of Building

The plot is on a gradient. The location of the entrances at ground floor level should take into account any variance in external levels. There should be visual interest and a variety of type and colour to the retail and commercial frontages. The design of the frontages should be complementary to the architectural typology and draw upon the existing St Helier street-scape for inspiration.

6.8.8.6 - Entrances must have level access even where a change in level occurs.

6.8.8.7 - The floor to floor height at ground floor varies to provide level access to the communal residential must be a maximum of 6.3m.

6.8.8.8 - Plot E2 should not provide ground level commercial uses (see Chapter 4.1.3 Use Distribution).

6.8.8.9 - Residential lobbies should be set in from street unless sufficient space is provided on the lane way. Entrances should have mainly glazed frontages with options for further solid/inset materials. Where required glazed main entrance residential lobbies should have either integrated revolving doors or wind lobbies. See figure 6.563.

Legend

 Zone for material variance and signage

 Zones for portal/inset framing detail

 Zone for glazed entrance

A+B Wind lobby (C) or integrated revolving door (D) arrangements for residential lobbies

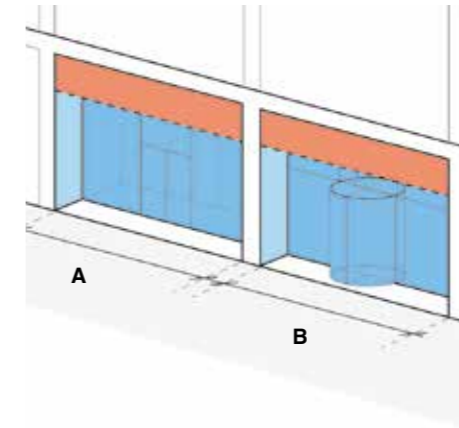

Figure 6.563 Illustrative example of wind lobbies or revolving doors at building entrances

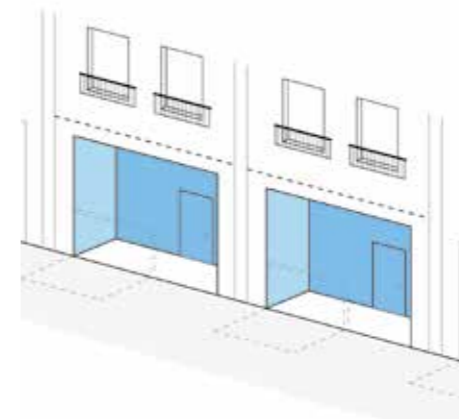

Figure 6.564 Illustrative example of a protected residential duplex entrance

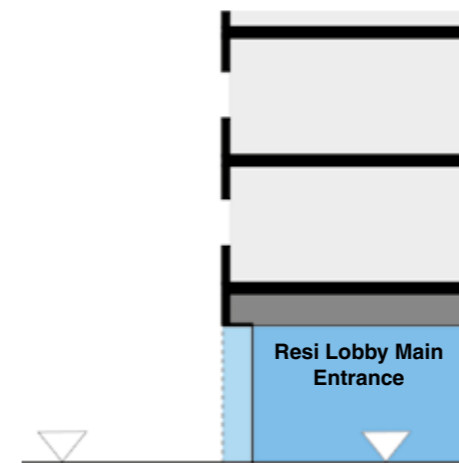

Figure 6.565 All primary entrances to have level access



Figure 6.566 Example of a duplex residential entrances directly onto street



Figure 6.567 Example of a duplex residential entrance to street



Figure 6.568 Example of a glazed residential lobby entrance

6. Plot Guide

6.8 Plot E2

6.8.9 Adjacent Buildings

E2 BUILDING ADJACENCIES

Plot E2 is located within close proximity to plots D2, E1 and E3 and the Horizon development.

6.8.9.1 - Consideration for balcony placement and openings should be taken to minimise proximity issues where façades face onto closely adjacent plots such as D2, E1 and E3, see also section 6.8.10 and 6.8.11.

6.8.9.2 - Consideration of window placement and directional framing should be taken where plots are directly adjacent to one another to minimise overlooking, see chapter 5.18 Proximity and Overlooking.



Figure 6.569 Plot E2 Building adjacencies key plan

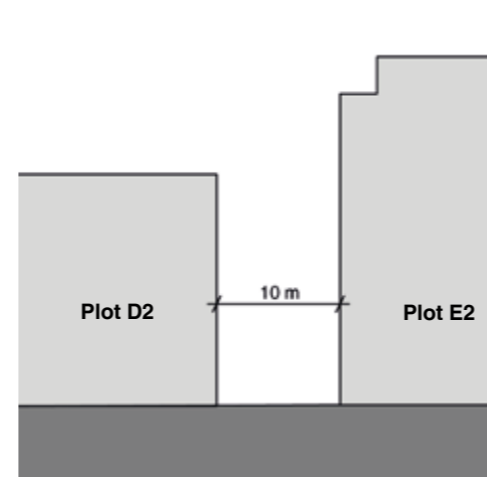

Figure 6.570 Building adjacency between D2 and E2

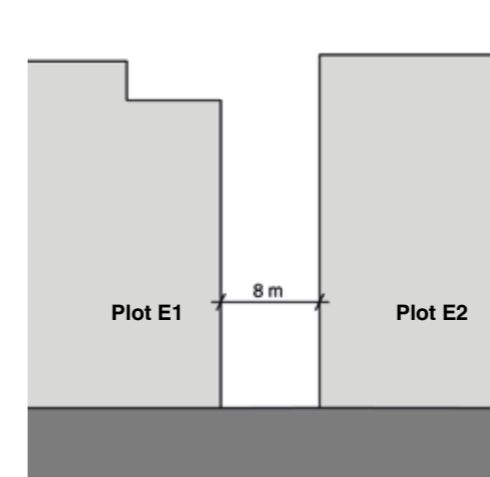

Figure 6.571 Building adjacency between E1 and E2

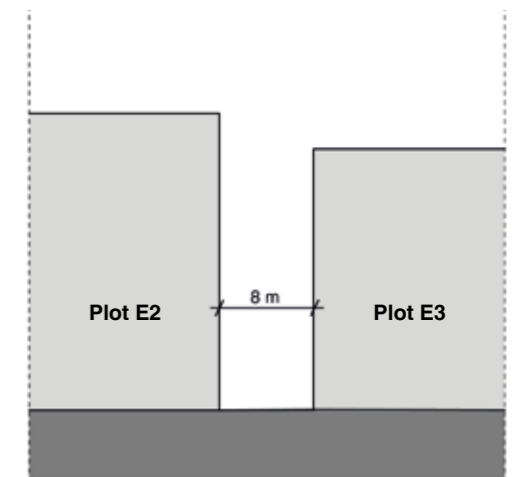

Figure 6.572 Building adjacency between E2 and E3

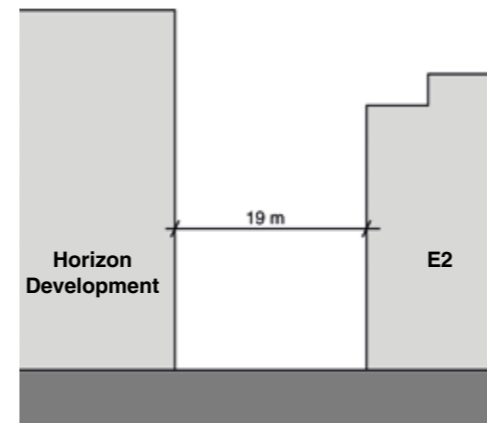

Figure 6.573 Building adjacency between Horizon and E2

6. Plot Guide

6.8 Plot E2

6.8.10 Openings

E2 OPENINGS IN THE FAÇADE

Designers should pay careful attention to the placement of openings across the façade. Whilst different opening compositions should be considered, they should also be as part of a coherent façade design strategy.

6.8.10.1 - Windows should form consistent patterns across the façade, allowing a degree of variation. See figures 6.574 and 6.575.

6.8.10.2 - Dormers and mansard roofs must not be used on plot E2. See figures 6.576 and 6.577.

6.8.10.3 - All façades should have a considered level of detail to the window openings - depth, reveals and framing, to give a high quality layered result.

6.8.10.4 - Areas for building services should be treated as screened openings with colour and materiality to work with façade materials (e.g. Louvres/ventilation grills), for a coherent elevation strategy. These should be minimised on principal elevations wherever possible.

6.8.10.5 - Consideration for access for the cleaning, maintenance and potential replacement of all elements should be given when designing openings.

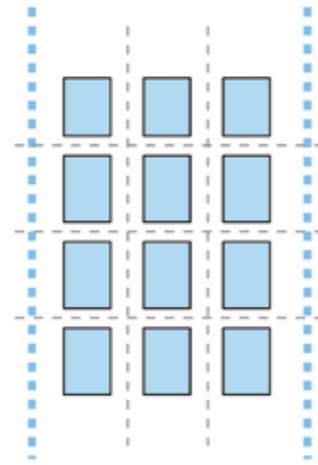

Figure 6.574 Gridded window layout

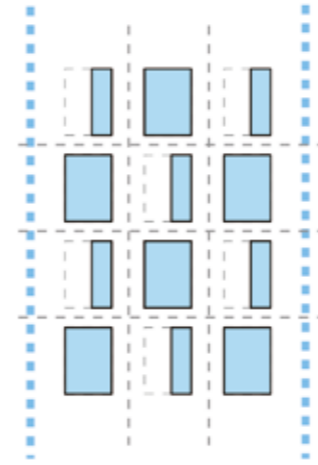

Figure 6.575 Gridded window layout with slipped windows



Figure 6.576 Double mansard windows

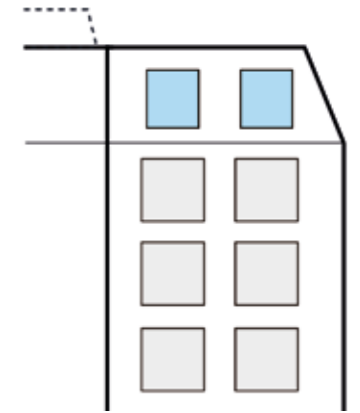

Figure 6.577 Single mansard windows



Figure 6.578 Double mansard/pitched inhabited roof



Figure 6.579 Single mansard/pitched inhabited roof

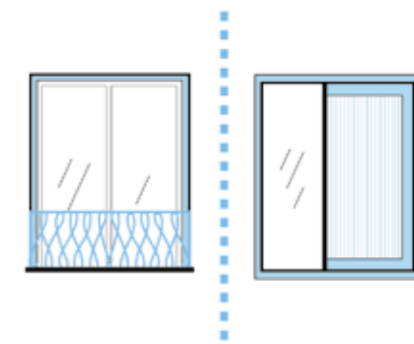

Figure 6.580 Variation in window detail

6. Plot Guide

6.8 Plot E2

6.8.11 Balconies

E2 BALCONY CONDITIONS

The balcony arrangement should be carefully positioned as part of the overall composition of the façade.

Consideration of the balcony location should be taken into account in order to avoid overlooking and proximity issues.

Consideration of the balcony location within the façade should be taken into account to avoid unnecessary shading to the rooms below.

It is suggested that the overall predominant balcony be inset with juliet used for façade variation e.g. 70% inset - 30% juliet on the southern and eastern facing façades. Elsewhere it is suggested that there is a façade variation of 40% proud, 40% inset and 20% juliet balconies.

6.8.11.1 - Inset, projecting and juliet balconies are permitted.

6.8.11.2 - Proud balconies are not permitted where proximity prohibits, see Chapter 5.18 Proximity and Overlooking for further guidance.

6.8.11.3 - Balustrades can vary in design but must be complementary to the façade design.

6.8.11.4 - A minimum balustrade height of 1.1m must be provided for all balconies.

6.8.11.5 - Horizontally barred balustrades are not permitted as they are a climbing hazard.

6.8.11.6 - There should be variation in colour and material of balustrading as well as specific highlighting materials to the returns and soffits of any inset balconies for visual interest and variation across façades.

6.8.11.7 - Corner balconies should be integrated into the façade with indicated on figure 6.581.

6.8.11.8 - Proud balconies should start at the first typical residential floor.

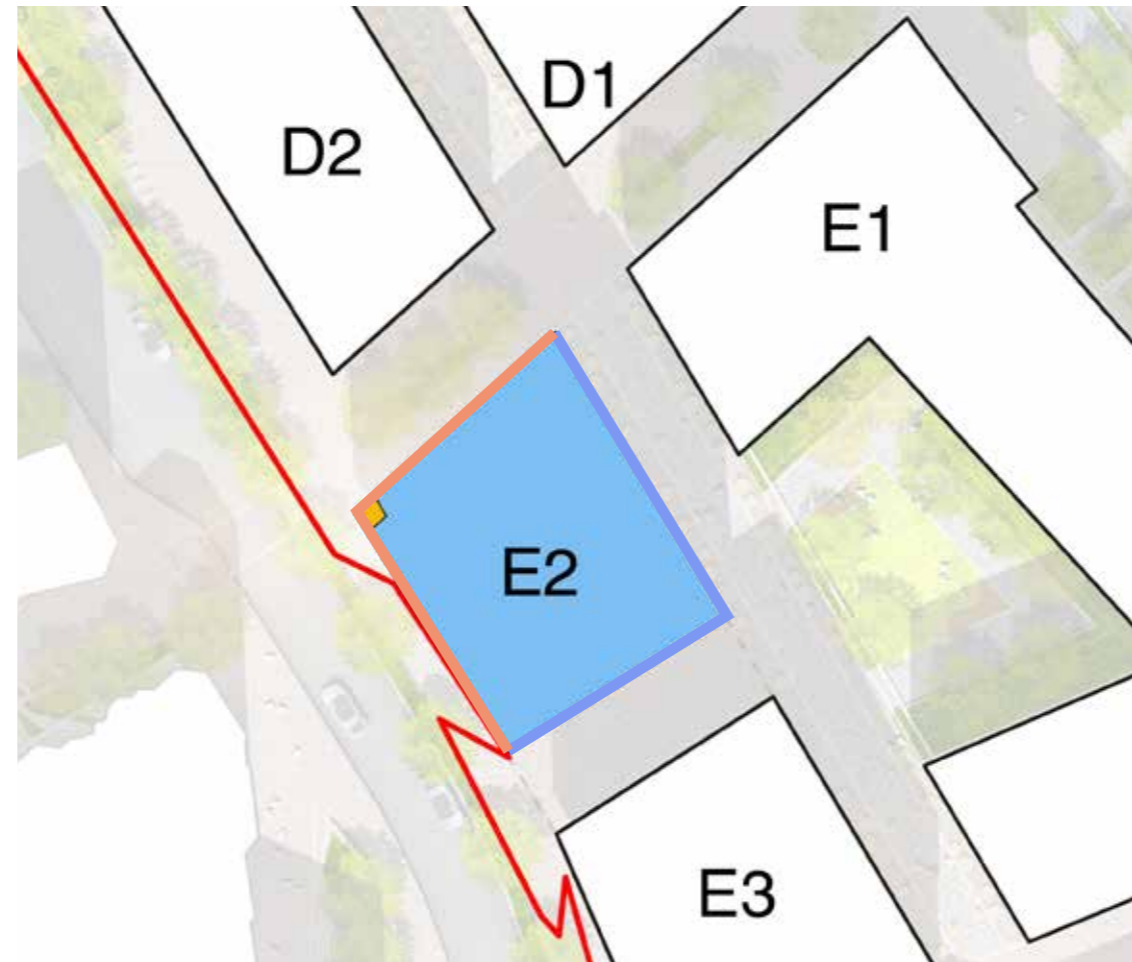

Figure 6.581 Plot E2 balcony condition key plan

Legend

- Building boundary
- Inset, juliet and proud balconies
- Inset and juliet balconies
- Inset corner balcony

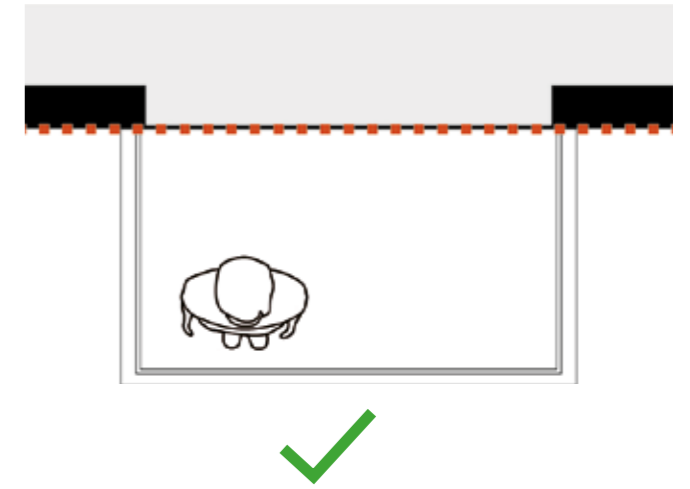

Figure 6.582 Proud balcony condition

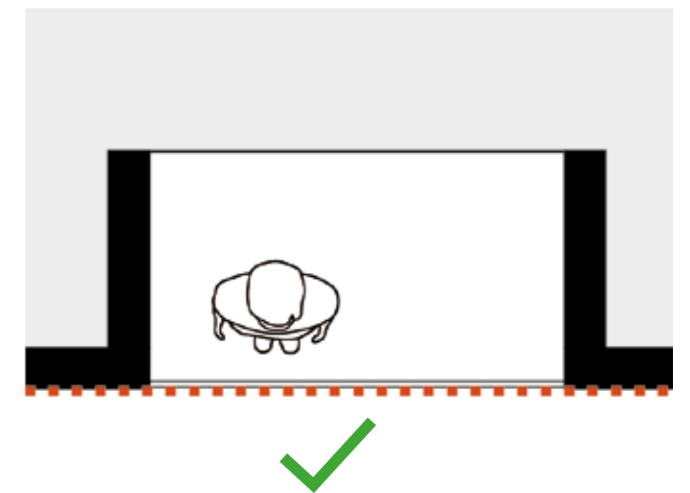

Figure 6.583 Inset balcony condition

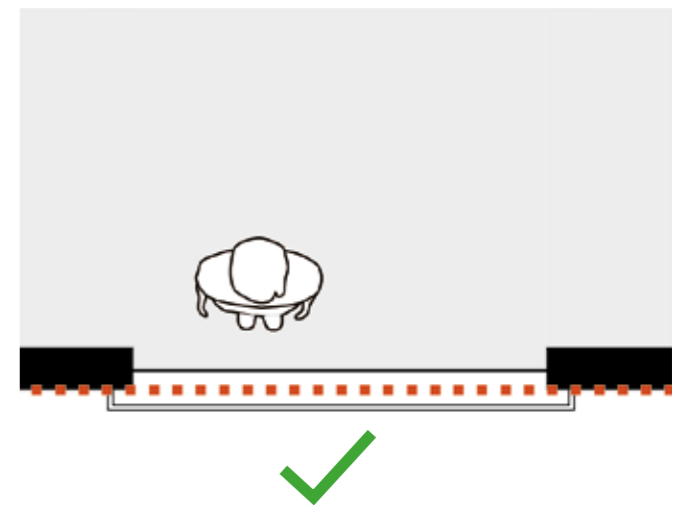

Figure 6.584 Juliet balcony condition

6. Plot Guide

6.8 Plot E2

6.8.12 Material Appearance

Hard-wearing and long-life quality materials should be selected. This should take inspiration from the existing local façade colours, textures and materials and new or complementary material types can be introduced where appropriate.

Care should be taken when sourcing all materials to ensure minimum environmental impact and the sustainable credentials of the source and the materials lifecycle, see Chapter 6.9 of SWSH Visioning Framework Sustainability Statement for further guidance.

The inner courtyards to the residential neighbourhoods form a series of more informal, human scale experiences along the lane way characterised by community gardens and a finer grain to the architectural detailing and use of materials. This is in contrast to the more robust, formal elevational treatments to the outward facing elevations of the residential neighbourhoods that form the edges to major streets and routes.

The primary material palette for the façade of the E2 Neighbourhoods typology should be drawn from both the St Helier local stone types as full stone clad items in conjunction with a mix of re-constituted stone 'frame and infill' approaches.

The secondary material palette for areas of roof of Plot E2 could include various 'infill' material options to add life, vibrancy and character to the residential neighbourhoods.

The tertiary material palette for all framing, detailing and areas of variation or highlight within inset infill zones, balconies, balustrades and openings across façades of Plot E2 could include an expanded palette of metals including wood, terracotta, glazed brick/tile and ceramic elements, with associated pattern and texture/relief options for further interest.

6.8.12.1 - Warm and restrained natural tones of stone should be considered in particular local, or equivalent granites, limestones, and equivalent reconstituted stones in a similar tone where a building is completely stone clad.

6.8.12.2 - Warm and restrained natural tones of stone, reconstituted stones and concretes should be used for the overall enclosure or 'frame' where a building is utilising the 'frame and infill' approach.

6.8.12.3 - Material selection should consider material used on neighbouring plot façades.

6.8.12.4 - Material selection should be responsive to the neighbouring Horizon buildings.

6.8.12.5 - Materials palette used in the inner courtyards should use a finer grain of architectural detailing to create 'softer' approach as set in the Neighbourhoods typology.

6.8.12.6 - Promotion of the use of materials that incorporate recycled content and procuring products with a low environmental impact should be a priority when choosing materials. For further guidance see Chapter 6.9 of SWSH Visioning Framework Sustainability Statement.

6.8.12.7 - The secondary material palette should be complementary to the primary composition.

6.8.12.8 - The materials palette for areas of façade that extend to form roof upstands should either be formed from the primary palette or include various 'infill' material options to add life, vibrancy and character.

6.8.12.9 - The tertiary material palette should be complementary to the primary and secondary composition.

6.8.12.10 - Exuberant and varied palettes of materials should be used as the tertiary palette to introduce patterning, texturing and finer detail.

6.8.12.11 - All materials should be hard wearing and suitable for a marine environment.

6.8.12.12 - Colours for the window frames, door frames, balcony metalwork and other architectural and design features must be complementary to the materials used on the rest of the building.

PRIMARY PALETTE



Figure 6.585 Limestones



Figure 6.586 Re-constituted Stone



Figure 6.587 Granites

SECONDARY AND TERTIARY PALETTES



Figure 6.589 Concrete, light brick as well as GRCs and metals



Figure 6.590 Acetylated or equivalent woods, terracotta, pre-oxidised and/or sealed/ coated pre-weathered metals and glazed brick/ tiles

This Page is Left Intentionally Blank

6. Plot Guide

6.9 Plot E3

6.9.1 Overview

PLOT OVERVIEW

Plot E3 is located in the southern part of the site and is part of the Neighbourhoods typology as described in Chapter 5.9 - Architectural Typologies. It is a 'Square' shaped building which, in conjunction with plot E2, encloses a semi private communal courtyard of E1. It has a key western elevation on Rue de L'etau.

6.9.1.1 - The use for plot E3 should include food and beverage, with residential use on all floors.

6.9.1.2 - Non-residential uses are permitted at ground floor only. For the floors above only residential use is permitted.

6.9.1.3 - The maximum plot parameter diagrams identify the maximum extent permissible of the building and should be read with the parameter plans. See figures 6.694 and 6.695.

6.9.1.4 - Plot E3 should allow for duplex units at ground level.

6.9.1.5 - All building elements with the exception of projecting balconies, canopies and awnings must be designed within the maximum plot parameters.

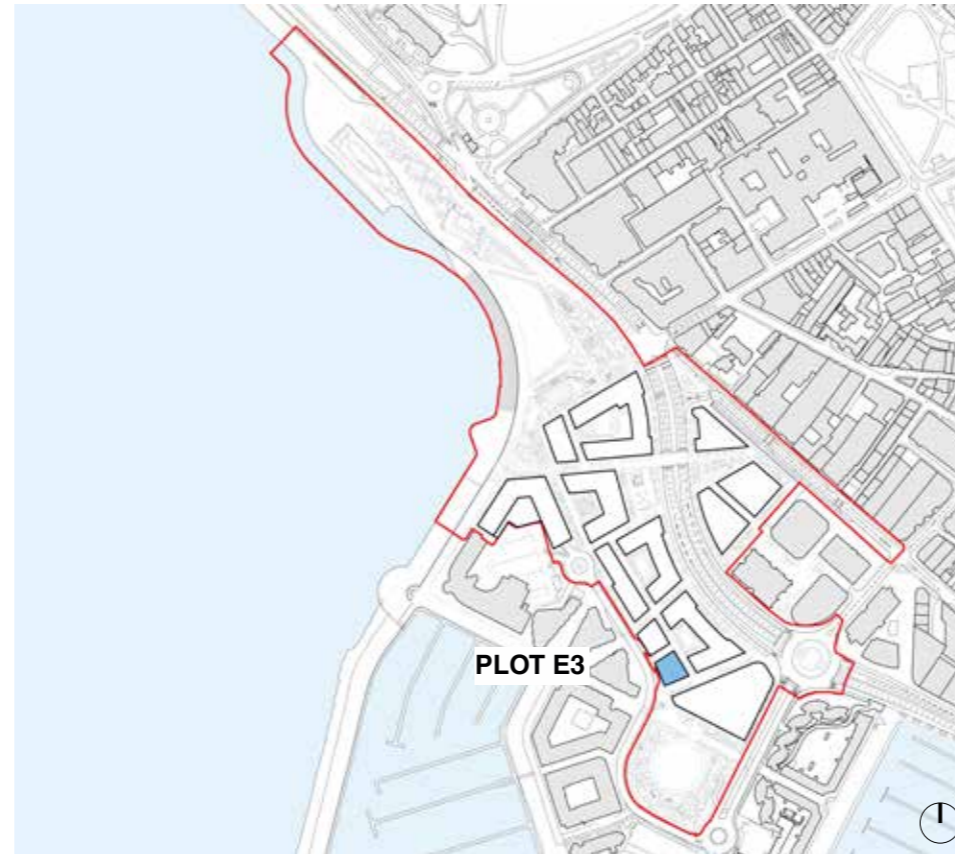

Figure 6.592 Plot parameters key plan

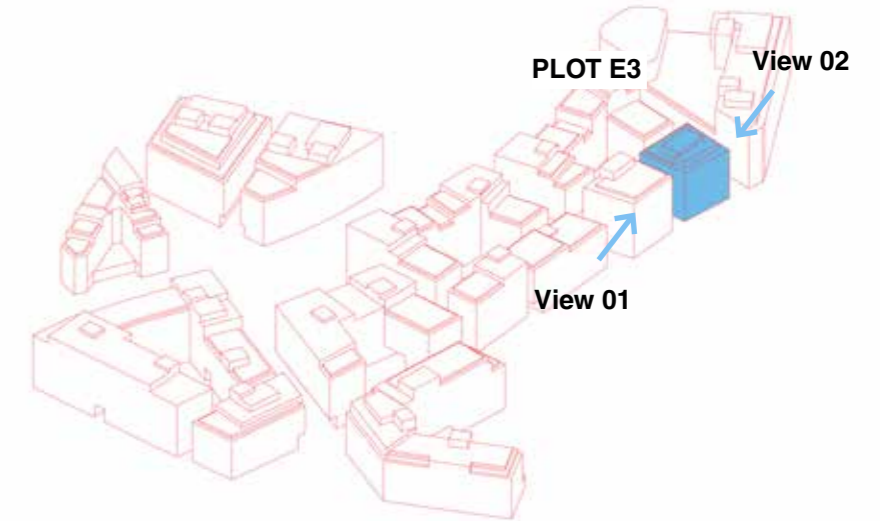

Figure 6.593 Plot parameters key diagram

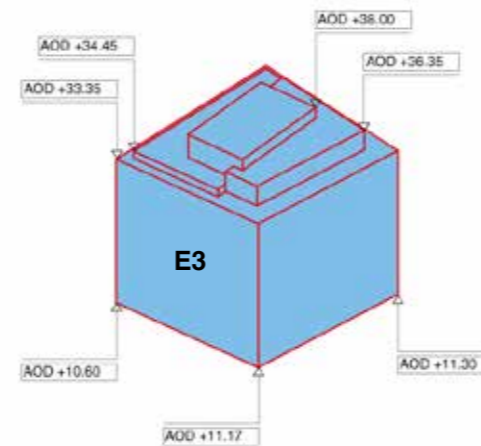

Figure 6.594 Maximum plot parameters diagram - View 01

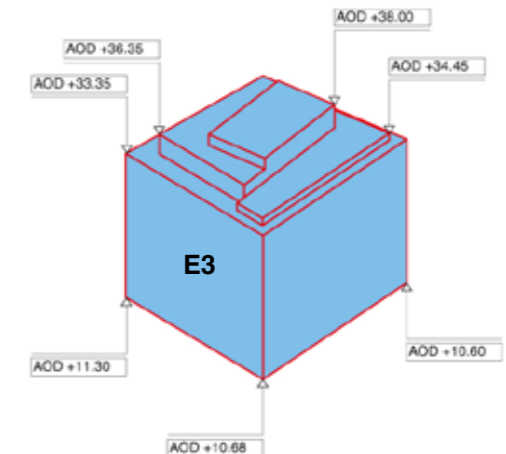

Figure 6.595 Maximum plot parameters diagram - View 02

6. Plot Guide

6.9 Plot E3

6.9.2 Plot Overview

Plot E3 is part of the Neighbourhood typology, with a calm 'neighbourhood' feel designed to support a new community of waterfront residents keen to live, work and play in St Helier and well supported by local shops and community provision.

Figure 6.613 demonstrates how plot E3 is located within the illustrative landscape framework, and provides key plot dimensions.

For further details on dimensions of key routes and codes relating to Plot E3's relationship with the public realm please refer to Chapter 4 - Prescription of Future of Development - Public Realm and Open Space, of this document set.

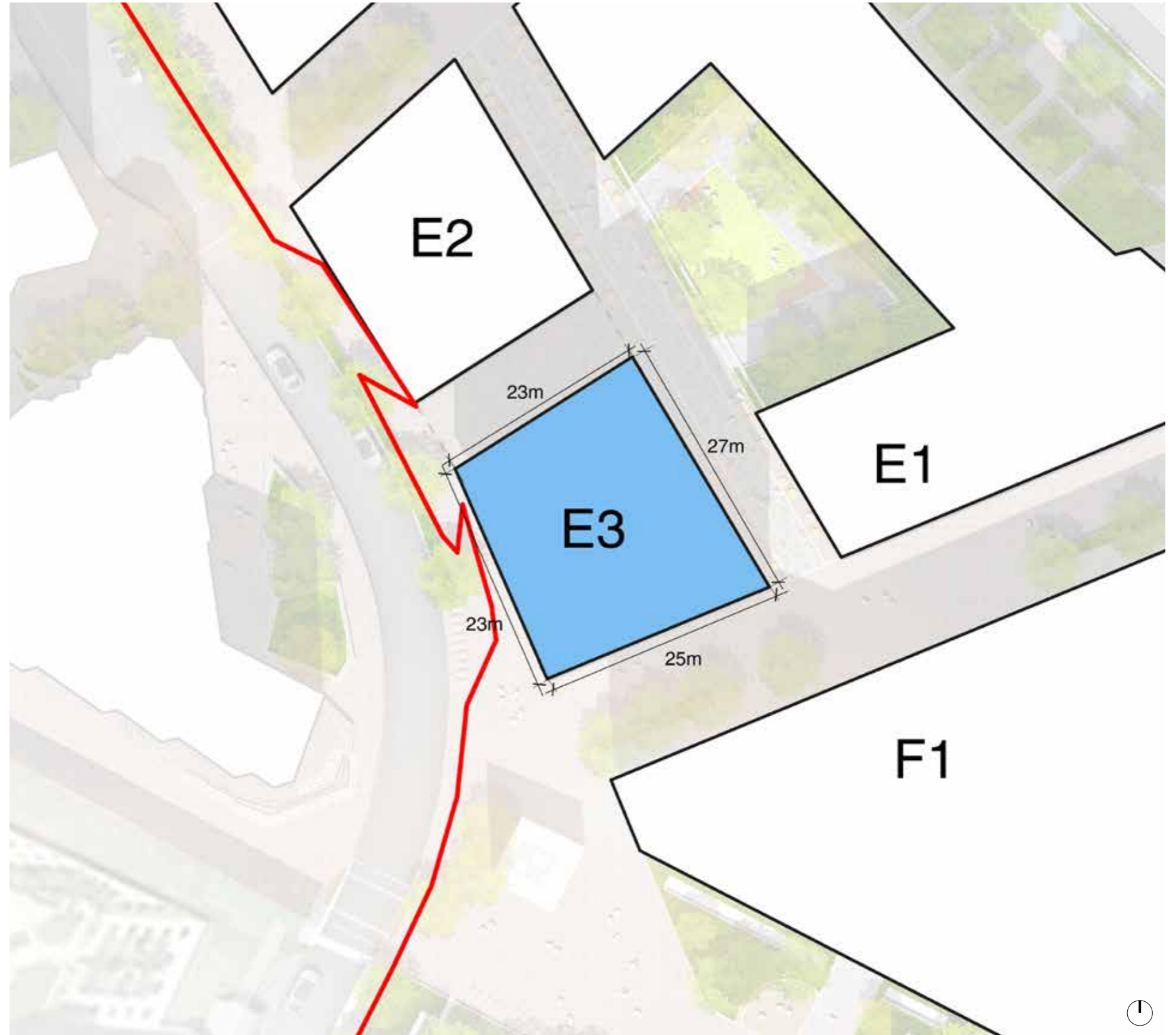

Figure 6.596 Ground floor plan

Legend

 Plot E3

 Adjacent Plots

6. Plot Guide

6.9 Plot E3

6.9.3 General Appearance

The analysis in Chapter - 5.8 Approach to Architecture of the design and access statement indicates the plot should respond in scale and façade articulation to the adjacent character areas. The overall approach is to create a high quality building with a distinct frontage that contributes to the identity of the residential neighbourhoods.

The architectural language of each façade should be consistent although the composition may vary to respond to specific considerations e.g. proximity to neighbouring plots and daylight/sunlight.

6.9.3.1 - The elevations should respond appropriately to their setting and their expression should complement the architectural language of plots E1, E2 and F1.

6.9.3.2 - Plot E3 is part of the Neighbourhoods typology. All elevations should respect their typology and should also consider the character of the Leisure Quarter typology of the buildings opposite Rue de L'etau.

6.9.3.3 - Windows should have deep reveals to provide adequate depth to the façade.

6.9.3.4 - The building envelope must define a clear bottom, middle and top through the architectural expression and treatment of the façade. See figure 6.597.

6.9.3.5 - Consideration must be given to how duplex units are integrated into the building at ground floor level.

6.9.3.6 - There must be depth and layering in the articulation of the façades to provide a sense of quality.

6.9.3.7 - The architectural language should use a blend of punched and expressed windows with frame reveals and full height windows and infill to expressed structural frame to all elevations.

6.9.3.8 - Variations in depth, height and materials should be used to break down the horizontal elevation into distinct vertical proportions. See figure 6.598.



Figure 6.597 Plot E3 - The Neighbourhoods reference elevation top, middle and bottom clearly defined by ground and roof treatments

6. Plot Guide

6.9 Plot E3

6.9.4 Wind mitigation

The impact of wind on the public and private realm environment should be mitigated by the incorporation of design features highlighted in the SWSH Visioning Framework Wind and Microclimate Assessment.

6.9.4.1 - Rooftop balustrades and set backs must be considered as indicated in section 6.9.6 - Top of Building.

6.9.4.2 - Corner inset balconies must be considered as indicated in the section 6.9.11 - Balconies and figure 6.601 opposite.

6.9.4.3 - Awnings should be considered for retail.

6.9.4.4 - Wind mitigation solutions should be complementary to overall architectural typology design and integrated into the building design.

6.9.4.5 - The design of plot E3 must incorporate wind mitigation measures as identified in the wind chapter of the EIS, or alternative equivalent measures to achieve the same mitigation effect developed and tested through detailed design.

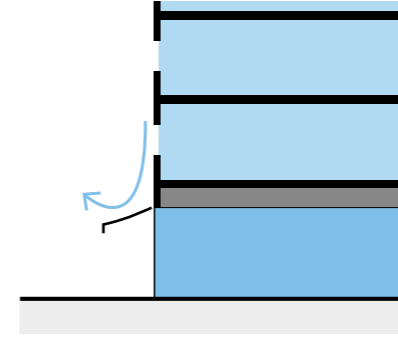

Figure 6.599 Awnings for wind for mitigation

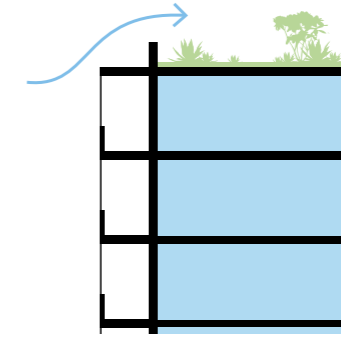

Figure 6.600 Upstand for wind mitigation

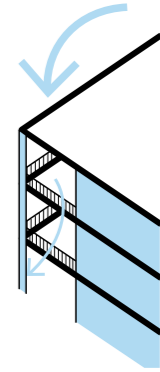

Figure 6.601 Inset balconies on corners for wind mitigation



Figure 6.602 Example of awnings



Figure 6.603 Example of upstand



Figure 6.604 Example of inset balconies

6. Plot Guide

6.9 Plot E3

6.9.5 Massing

A maximum AOD has been established for Plot E3. The maximum AOD allows for lobby access to the rooftop amenity space.

Within these maximum extents upstands should be used to enclose amenity space on roofs as a wind mitigation device.

6.9.5.1 - The ground floor should have additional height to accommodate residential duplex use. See figure 6.622 below.

6.9.5.2 - The maximum number of storeys permissible for Plot E3 is 6 storeys (ground plus 5). See figure 6.623 for indicative floor to floor setting out.

6.9.5.3 - Figure 6.623 identifies the maximum shoulder heights permissible.

6.9.5.4 - Balustrades and privacy screens may project above the shoulder height provided they are contained within the accessible terrace zone as indicated in figure 6.624.

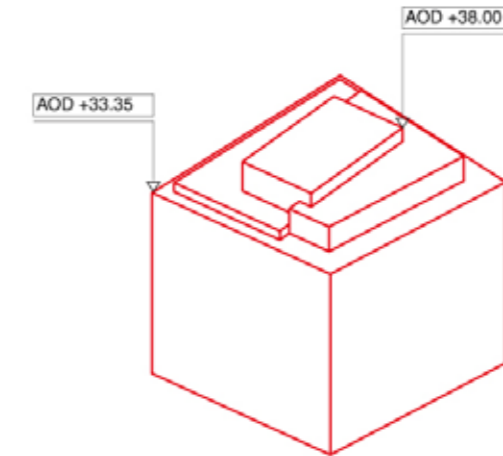

Figure 6.606 Plot E3 Maximum plot parameters showing shoulder heights

Legend

- Maximum plot parameters
- +6.3m floor to floor bottom zone
- Indicative shaped massing where applicable
- Suggested roof treatment & accessible terrace zones

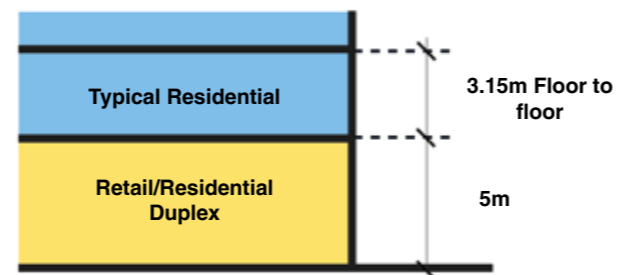

Figure 6.605 Typical floor to floor

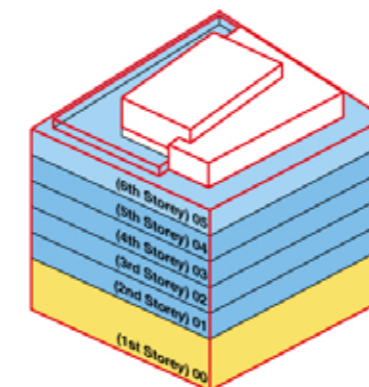

Figure 6.607 Plot E3 Indicative massing set up within maximum plot parameters

6. Plot Guide

6.9 Plot E3

6.9.6 Top of the Building

E3 TOP OF THE BUILDING - ROOF PROFILES

General approach to E3 is to have set back upstands to maintain perceived building height.

6.9.6.1 - Accessible terrace zones must be provided and should be set back from the façade by a minimum of 1.5m and have an upstand of minimum 1.1m. See figures 6.609 and 6.611.

6.9.6.2 - Where the accessible roof terrace is directly adjacent to the plant technical zone, the design of the plant enclosure should be considered.

6.9.6.3 - Perimeter and setback upstands for shelter and guarding should be provided to all accessible roofs.



Figure 6.608 Plot E3 Rooftop setback plan

Legend

- Maximum plot parameters
- Indicative suggested massing
- Accessible flat roof terrace
- Non-accessible roof
- Indicatively placed Technical/Plant Zones
- Indicative Core Positions

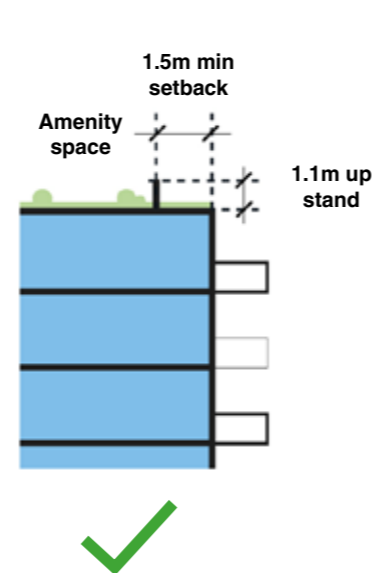

Figure 6.609 Upstand up to max height 1.1m and 1.5m setback

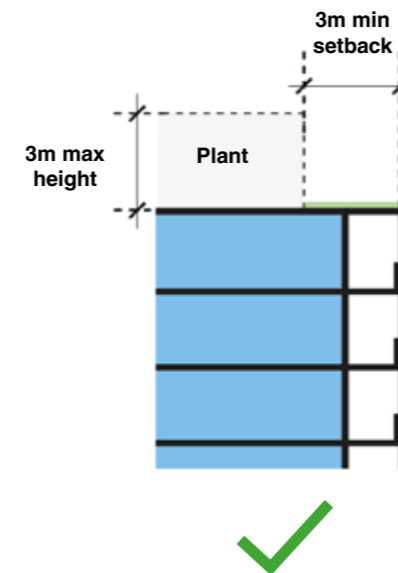

Figure 6.610 Plant setback 3m

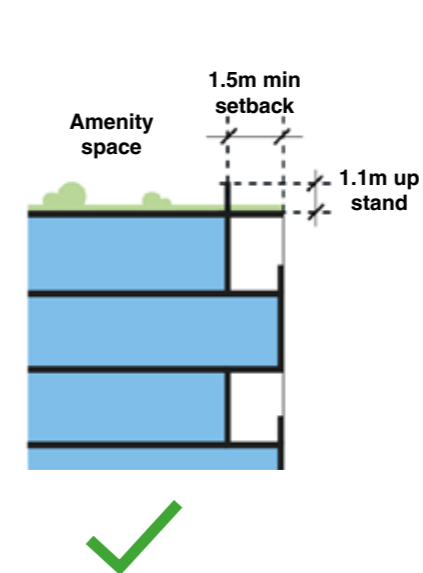

Figure 6.611 Upstand up to max height 1.1m and 1.5m setback

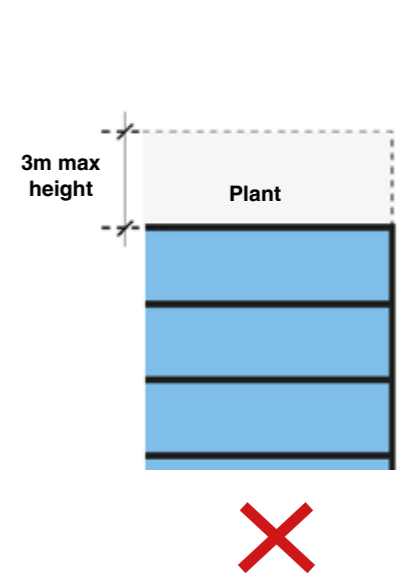

Figure 6.612 No flat roofs or plant

6. Plot Guide

6.9 Plot E3

6.9.6 Top of the Building

E3 TOP OF THE BUILDING - ROOF TECHNICAL ZONE

A maximum AOD has been established for Plot E3. The maximum AOD allows for lobby access to the rooftop amenity space.

Where not designated for accessible roof zones, a technical/plant zone exists that encompasses the maximum extents for any final arrangements of required plant.

All core positions, both full storey lobbied roof access extensions or nominal overruns, are shown indicatively.

6.9.6.4 - Any plant must be located within the technical zone and set back a minimum 3m from the façade line with a maximum 3m high enclosure. See figure 6.610 on previous page.

6.9.6.5 - Green or brown roofs should be provided to all non accessible roof areas.

6.9.6.6 - Any plant should not align directly to the perimeter of the façade. See figure 6.612 on the previous page.

6.9.6.7 - Where plant and technical zones cannot be setback 3m or aligns with the façade edge a façade upstand should be used of a maximum height of 3m.

6.9.6.8 - All core positions, both full storey lobbied access extensions or nominal overruns should be located within the technical zones.



Figure 6.613 Plot E3 Maximum extents and setback roof plan

Legend

- Maximum plot parameters
- Indicative suggested massing
- Set back zone for technical/plant areas (no plant in these areas)
- Maximum extents available for potential technical/plant zone
- Indicatively placed technical/plant zones
- Indicative core positions

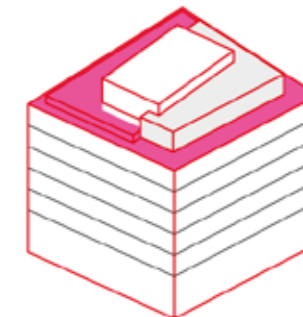

Figure 6.614 Plot E3 Available technical zones within maximum plot parameters

6. Plot Guide

6.9 Plot E3

6.9.7 Middle of the Building

E3 MIDDLE OF THE BUILDING

The overall approach is to create an elegant, high quality building. The façades should provide a strong frontage, contributing to the identity of the development. The materials palette proposed includes natural and re-constituted stone and high quality pre-cast concrete (see section 6.10.13 Material Appearance).

The urban analysis suggests (DAS - 5.8 Approach to Architecture) the façades should have a varied and characterful mix of frontages around the residential neighbourhoods.

A regular sub-grid should be set-up to coordinate the rhythm of the windows and balconies. Balcony positions should complement any desired façade subdivision with further variation via the use of inset, juliet and proud balconies.

6.9.7.1 - All elevations must respond appropriately to their setting and their expression should complement the architectural language of Plots E1, E2, F1 and the Horizon buildings opposite.

6.9.7.2 - The elevations should respond appropriately to their setting and their expression should follow the architectural language of the Neighbourhoods typology.

6.9.7.3 - There must be depth and layering in the articulation of the façades to provide a sense of quality.

6.9.7.4 - Designers should follow the glazing percentage per façade as set out in the Chapter 5.17 Windows.

6.9.7.5 - Window layouts should follow overall gridded arrangements as illustrated in the indicative figure 6.616.

6.9.7.6 - The architectural language of the façades should continue to ground level to allow for the incorporation of duplex units. See figure 6.616.

6.9.7.7 - Corner features including balconies should be considered as part of the building design.

6.9.7.8 - The architectural language should use full height windows and infill to expressed structural frame to all elevations. This is to create frontage proportion and subdivision to the elevation. See figure 6.616.

6.9.7.9 - Architectural details should consider devices that include but not limited to shadow gaps and joint lines to express the unit divisions and rhythms.

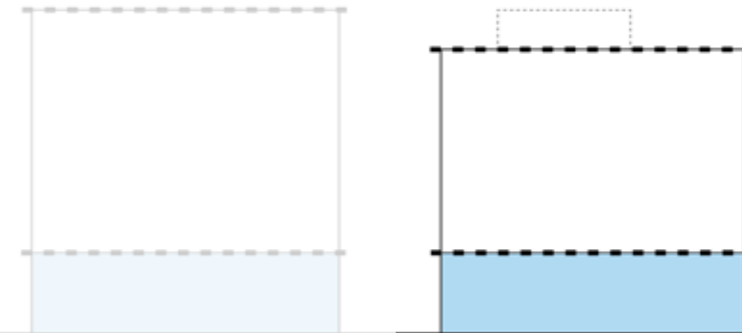

Figure 6.615 Plot E3 Elevation - top, middle, bottom



Figure 6.616 Plot E3 Elevation - frontage proportion and subdivision

6. Plot Guide

6.9 Plot E3

6.9.8 Bottom of the Building

There may be a number of entrances required on this building including one or more retail entrances and secondary entrances that include fire escape and/or service entrance(s).

All entrances should be carefully integrated into the façade and should be coherent with the façade material expression.

6.9.8.1 - A minimum of one residential entrance and associated lobby are to be provided within the zones identified. See figure 6.617.

6.9.8.2 - Entrances must be clearly legible through articulation and design and must have a high quality appearance.

6.9.8.3 - All entrances must be carefully integrated into the massing of the building.

6.9.8.4 - The bottom of the building must have a strong architectural expression (see Chapter 5.16 Bottom of building).

6.9.8.5 - Non residential uses should have their own dedicated entrances.

6.9.8.6 - Awnings should be integrated into the design of the building façade.

6.9.8.7 - Plot E3 must have additional height at ground level to allow for the incorporation of residential duplex units as shown in figure 6.619.

Legend

 Zone for residential entrances

 Zone for retail entrances



Figure 6.617 Plot E3 bottom of building suggested condition

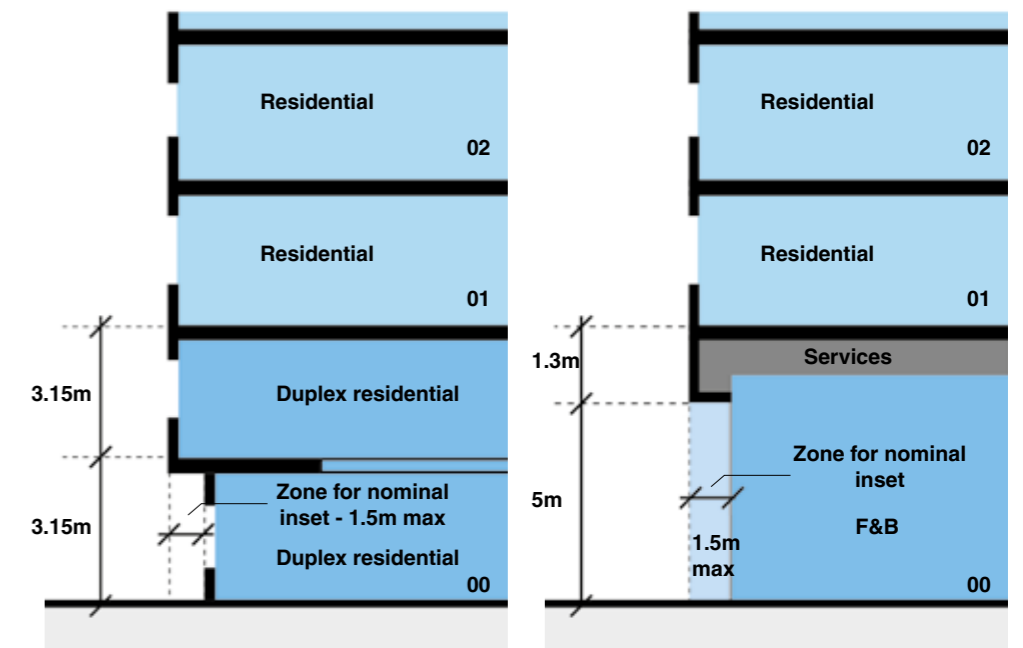

Figure 6.618 Duplex residential condition

Figure 6.619 Up to 1.5m nominal setback condition

6. Plot Guide

6.9 Plot E3

6.9.8 Bottom of the Building

The plot is on a gradient. The location of the entrances at ground floor level should take into account any variance in external levels. There should be visual interest and a variety of type and colour to the retail and commercial frontages. The design of the frontages should be complementary to the architectural typology and draw upon the existing St Helier street-scape for inspiration.

6.9.8.8 - Entrances must have level access even where a change in level occurs.

6.9.8.9 - The floor to floor height at ground floor varies to provide level access to the residential and non-residential entrances and must be a maximum of 6.3m.

6.9.8.10 - Plot E3 should provide ground level residential and food and beverage spaces (see chapter 4.1.3 Use Distribution).

6.9.8.11 - Non-residential frontages should be of a considered arrangement and complementary with the overall material palette of the typology. However a variety of materials and colours can be used for visual highlight. Other design variations to the frontages can be considered. See figure 6.621.

6.9.8.12 - Residential lobbies should be set in from street unless sufficient space is provided on the lane way. Entrances should have mainly glazed frontages with options for further solid/inset materials. Where required glazed main entrance residential lobbies to have either integrated revolving doors or wind lobbies. See figure 6.622.

Legend

- Zone for material variance and signage
- Zones for portal/inset framing detail
- Zone for glazed entrance
- Inset of nominal depth
- A** Glazed entrance with no bays (e.g. Retail use)
- B** Glazed entrance with double or single bay (double shown) for typical retail entrances
- C+D** Wind lobby (C) or integrated revolving door (D) arrangements for residential lobbies

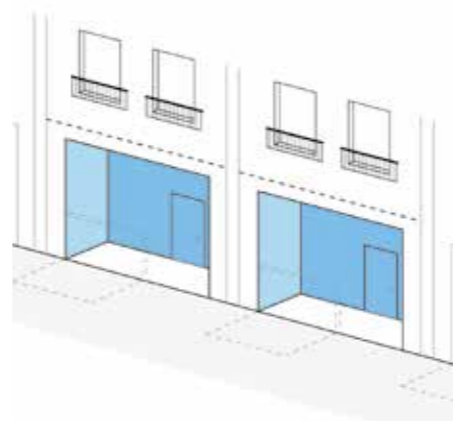

Figure 6.620 Illustrative example of a protected residential duplex entrance

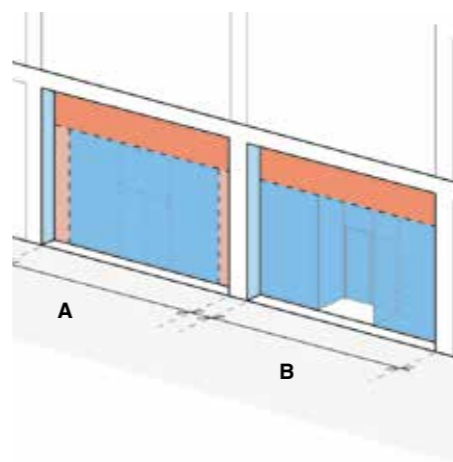

Figure 6.621 Illustrative example of non-bayed and bayed retail entrances

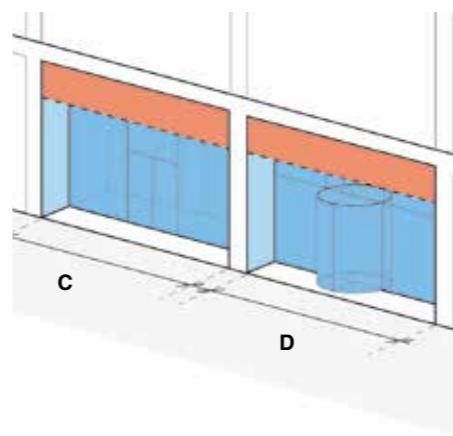

Figure 6.622 Illustrative example of wind lobbies or revolving doors at building entrances



Figure 6.623 All primary entrances to have level access



Figure 6.624 Example of seating integrated into retail frontages



Figure 6.625 Example of awnings to retail



Figure 6.626 Example of duplex residential entrance to street



Figure 6.627 Example of nominal inset to retail frontages especially where predominantly glazed



Figure 6.628 Example of a glazed residential lobby entrance

6. Plot Guide

6.9 Plot E3

6.9.9 Adjacent Buildings

E3 BUILDING ADJACENCIES

Plot E3 is located within close proximity to plots E1, E2 and F1.

6.9.9.1 - Consideration for balcony placement and openings should be taken to minimise proximity issues where façades face onto closely adjacent plots such as E1, E2 and F1, see also sections 6.9.10 and 6.9.11.

6.9.9.2 - Consideration of window placement and directional framing should be taken where plots are directly adjacent to one another to minimise overlooking, see chapter 5.18 Proximity and Overlooking.



Figure 6.629 Plot E3 Building adjacencies key plan



Figure 6.630 Building adjacency between E3 and F1

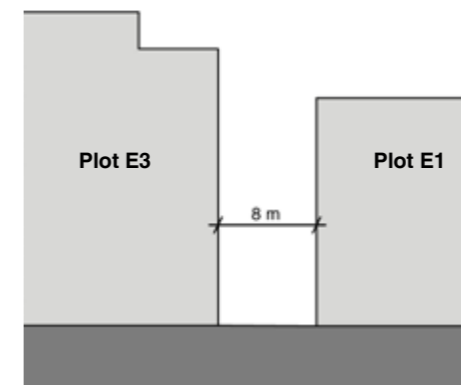

Figure 6.631 Building adjacency between E3 and E1

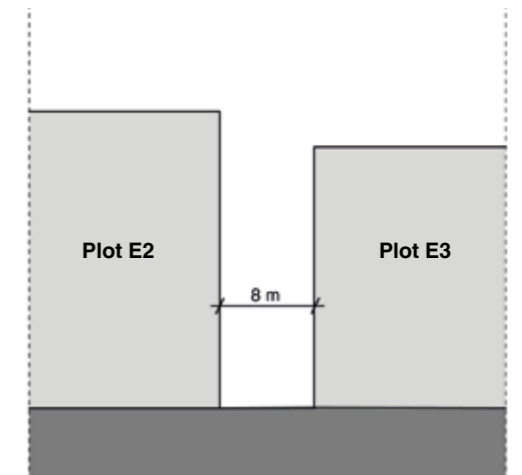

Figure 6.632 Building adjacency between E2 and E3

6. Plot Guide

6.9 Plot E3

6.9.10 Openings

E3 OPENINGS IN THE FAÇADE

Designers should pay careful attention to the placement of openings across the façade. Whilst different opening compositions should be considered, they should also be as part of a coherent façade design strategy.

6.9.10.1 - Windows should form consistent patterns across the façade, allowing a degree of variation. See figures 6.633 and 6.634.

6.9.10.2 - Dormers and mansard roofs must not be used on plot E3. See figures 6.635 and 6.636.

6.9.10.3 - All façades should have a considered level of detail to the window openings - depth, reveals and framing, to give a high quality layered result.

6.9.10.4 - Areas for building services should be treated as screened openings with colour and materiality to work with façade materials (e.g. Louvres/ventilation grills), for a coherent elevation strategy. These should be minimised on principal elevations wherever possible.

6.9.10.5 - Consideration for access for the cleaning, maintenance and potential replacement of all elements should be given when designing openings.

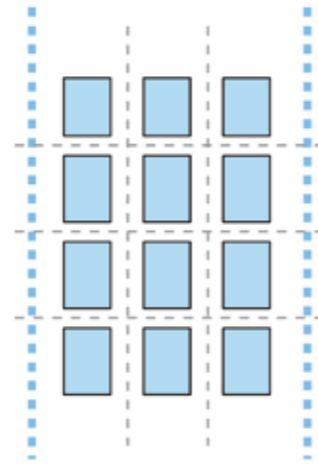

Figure 6.633 Gridded window layout

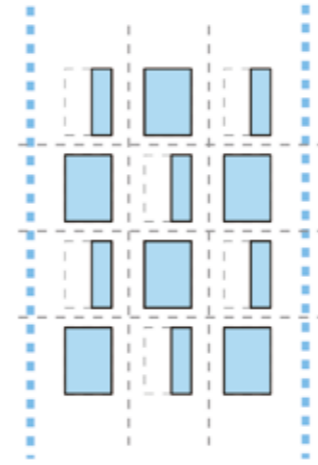

Figure 6.634 Gridded window layout with slipped windows



Figure 6.635 Double mansard dormer windows

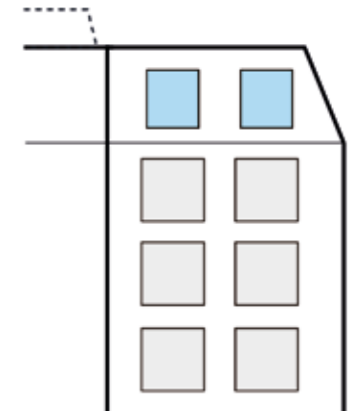

Figure 6.636 Single mansard dormer windows



Figure 6.637 Double mansard/pitched inhabited roof



Figure 6.638 Single mansard/pitched inhabited roof

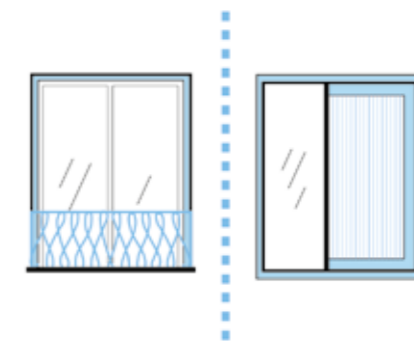

Figure 6.639 Variation in window detail

6. Plot Guide

6.9 Plot E3

6.9.11 Balconies

E3 BALCONY CONDITIONS

The balcony arrangement should be carefully positioned as part of the overall composition of the façade.

Consideration of the balcony location should be taken into account in order to avoid overlooking and proximity issues.

Consideration of the balcony location within the façade should be taken into account to avoid unnecessary shading to the rooms below.

It is suggested that the overall predominant balcony be inset with juliet used for façade variation e.g. 70% inset - 30% juliet on the northern and eastern facing façades. Elsewhere it is suggested that there is a façade variation of 40% proud, 40% inset and 20% juliet balconies.

6.9.11.1 - Inset, projecting and juliet balconies are permitted.

6.9.11.2 - Proud balconies are not permitted where proximity prohibits, see Chapter 5.18 Proximity and Overlooking for further guidance.

6.9.11.3 - Balustrades can vary in design but must be complementary to the façade design.

6.9.11.4 - A minimum balustrade height of 1.1m must be provided for all balconies.

6.9.11.5 - Horizontally barred balustrades are not permitted as they are a climbing hazard.

6.9.11.6 - There should be variation in colour and material of balustrading as well as specific highlighting materials to the returns and soffits of any inset balconies for visual interest and variation across façades.

6.9.11.7 - Corner balconies should be integrated into the façade as indicated in figure 6.640.

6.9.11.8 - Proud balconies should start at the first typical residential floor.

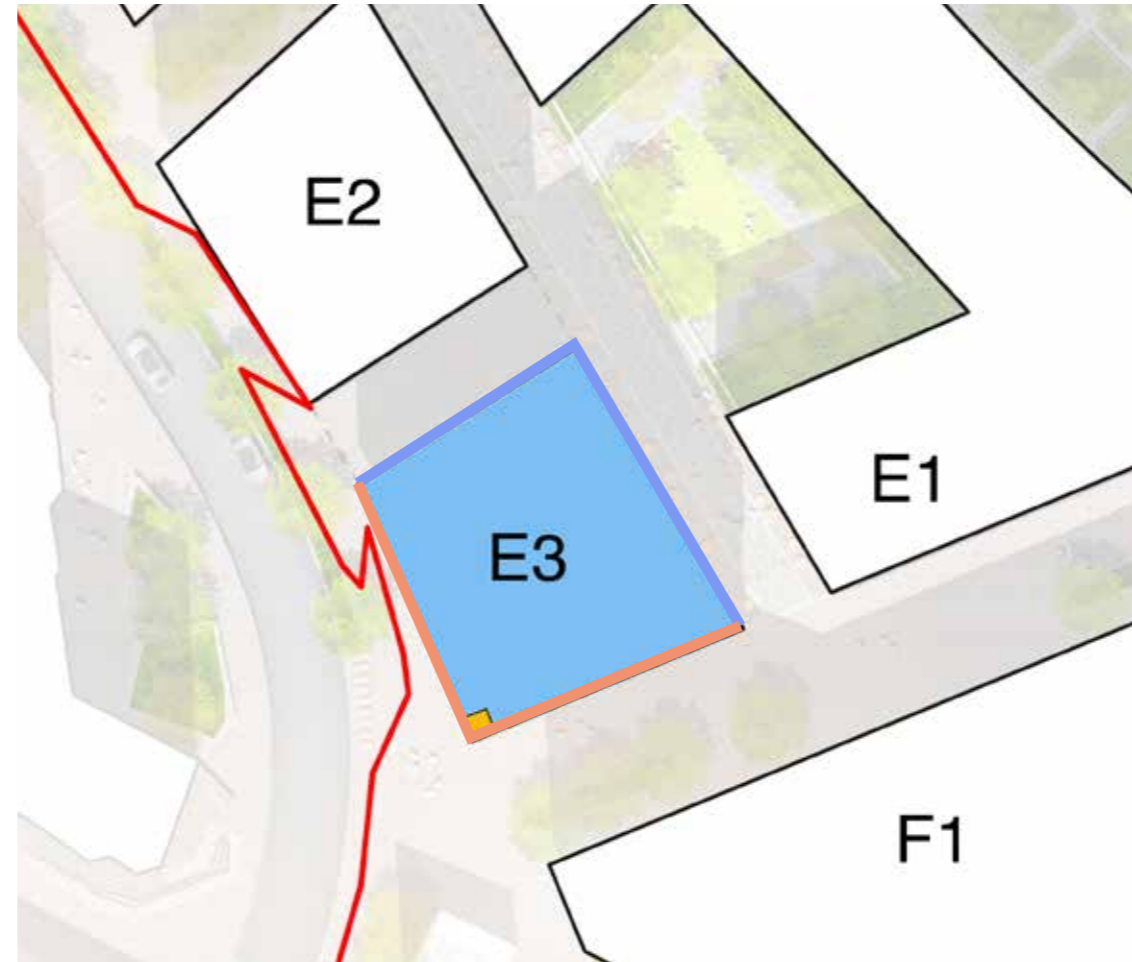

Figure 6.640 Plot E3 balcony condition key plan

Legend

- - - Building boundary
- Inset, juliet and proud balconies
- Inset and juliet balconies
- Inset corner balcony

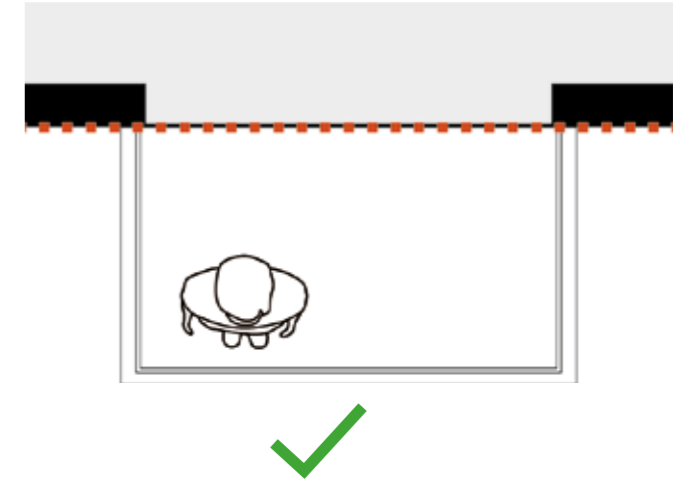

Figure 6.641 Proud balcony condition

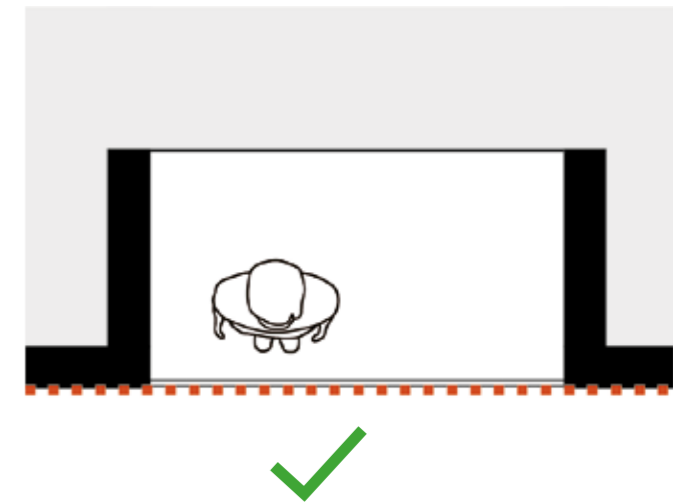

Figure 6.642 Inset balcony condition

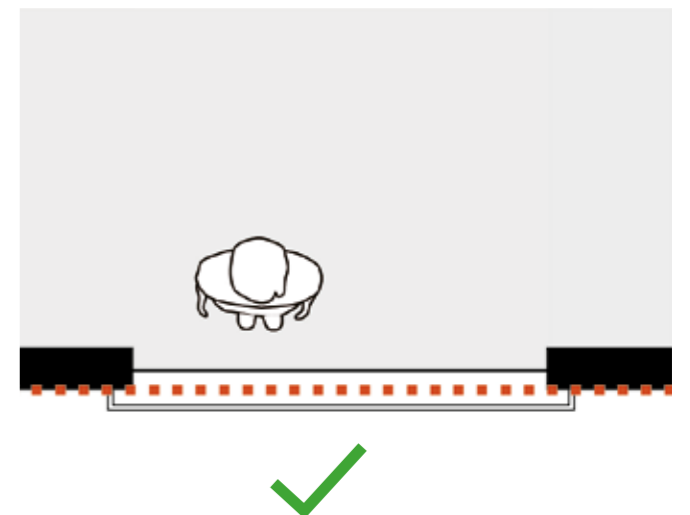

Figure 6.643 Juliet balcony condition

6. Plot Guide

6.9 Plot E3

6.9.12 Material appearance

Hard-wearing and long-life quality materials should be selected. This should take inspiration from the existing local façade colours, textures and materials and new or complementary material types can be introduced where appropriate.

Care should be taken when sourcing all materials to ensure minimum environmental impact and the sustainable credentials of the source and the materials lifecycle, see Chapter 6.9 of SWSH Visioning Framework Sustainability Statement for further guidance.

The inner courtyards to the residential neighbourhoods form a series of more informal, human scale experiences along the lane way characterised by community gardens and a finer grain to the architectural detailing and use of materials. This is in contrast to the more robust, formal elevational treatments to the outward facing elevations of the residential neighbourhoods that form the edges to major streets and routes.

The primary material palette for the façade of the E3 Neighbourhoods typology should be drawn from both the St Helier local stone types as full stone clad items in conjunction with a mix of re-constituted stone 'frame and infill' approaches.

The secondary material palette for areas of roof of Plot E3 could include various 'infill' material options to add life, vibrancy and character to the residential neighbourhoods.

The tertiary material palette for all framing, detailing and areas of variation or highlight within inset infill zones, balconies, balustrades and openings across façades of Plot E3 could include an expanded palette of metals including wood, terracotta, glazed brick/tile and ceramic elements, with associated pattern and texture/relief options for further interest.

6.9.12.1 - Warm and restrained natural tones of stone should be considered in particular local, or equivalent granites, limestones, and equivalent reconstituted stones in a similar tone where a building is completely stone clad.

6.9.12.2 - Warm and restrained natural tones of stone, reconstituted stones and concretes should be used for the overall enclosure or 'frame' where a building is utilising the 'frame and infill' approach.

6.9.12.3 - Material selection should consider material used on neighbouring plot façades.

6.9.12.4 - Material selection should be responsive to the neighbouring Horizon buildings.

6.9.12.5 - Materials palette used in the inner courtyards should use a finer grain of architectural detailing to create 'softer' approach as set in the Neighbourhoods typology.

6.9.12.6 - Promotion of the use of materials that incorporate recycled content and procuring products with a low environmental impact should be a priority when choosing materials. For further guidance see Chapter 6.9 of SWSH Visioning Framework Sustainability Statement.

6.9.12.7 - The secondary material palette should be complementary to the primary composition.

6.9.12.8 - The materials palette for areas of façade that extend to form roof upstands should either be formed from the primary palette or include various 'infill' material options to add life, vibrancy and character.

6.9.12.9 - The tertiary material palette should be complementary to the primary and secondary composition.

6.9.12.10 - Exuberant and varied palettes of materials should be used as the tertiary palette to introduce patterning, texturing and finer detail.

6.9.12.11 - All materials should be hard wearing and suitable for a marine environment.

6.9.12.12 - Colours for the window frames, door frames, balcony metalwork and other architectural and design features must be complementary to the materials used on the rest of the building.

PRIMARY PALETTE



Figure 6.644 Limestones



Figure 6.645 Re-constituted Stone



Figure 6.646 Granites

SECONDARY AND TERTIARY PALETTES



Figure 6.648 Concrete, light brick as well as GRCs and metals

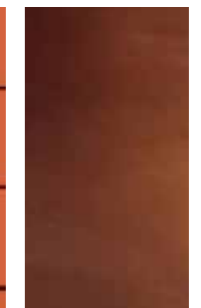
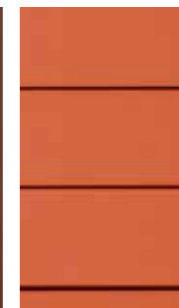

Figure 6.649 Acetylated or equivalent woods, terracotta, pre-oxidised and/or sealed/coated pre-weathered metals and glazed brick/tiles

This Page is Left Intentionally Blank

6. Plot Guide

6.10 Plot F1

6.10.1 Overview

PLOT OVERVIEW

Plots F1A and F1B occupy a large anchor plot at a prominent location on the southern end of the Framework. Together with the IFC development opposite it forms a new gateway into St Helier for visitors arriving from the harbour and a key elevation onto the Marina Gardens.

Plot F1A forms the northern part of the F1 plot and comprises the primary portion of new leisure facility that replaces the existing leisure complex. It overlooks La Route de la Libération and the Castle Street roundabout.

Plot F1B occupies the southern part of the plot and forms the residential component. It occupies the upper levels of the Marina Gardens park frontage with the leisure use continuing underneath at ground.

6.10.1.1 - The use for plot F1 should include food and beverage and leisure as part of the Leisure Quarter - Leisure component with residential on the upper floors.

6.10.1.2 - Residential uses are permitted above ground floor level on plot F1B only.

6.10.1.3 - The maximum plot parameter diagrams identify the maximum extent permissible of the building and should be read with the parameter plans. See figures 6.653 and 6.654.

6.10.1.4 - All building elements with the exception of projecting balconies, canopies and awnings must be designed within the maximum plot parameters.

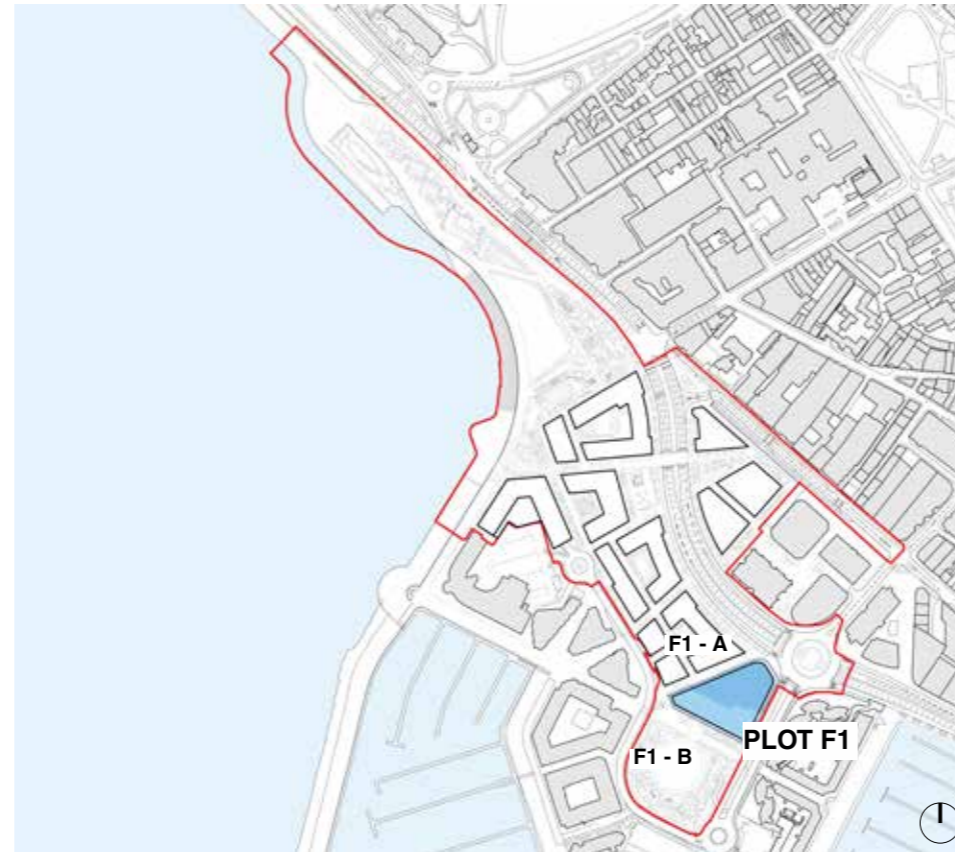

Figure 6.651 Plot parameters key plan

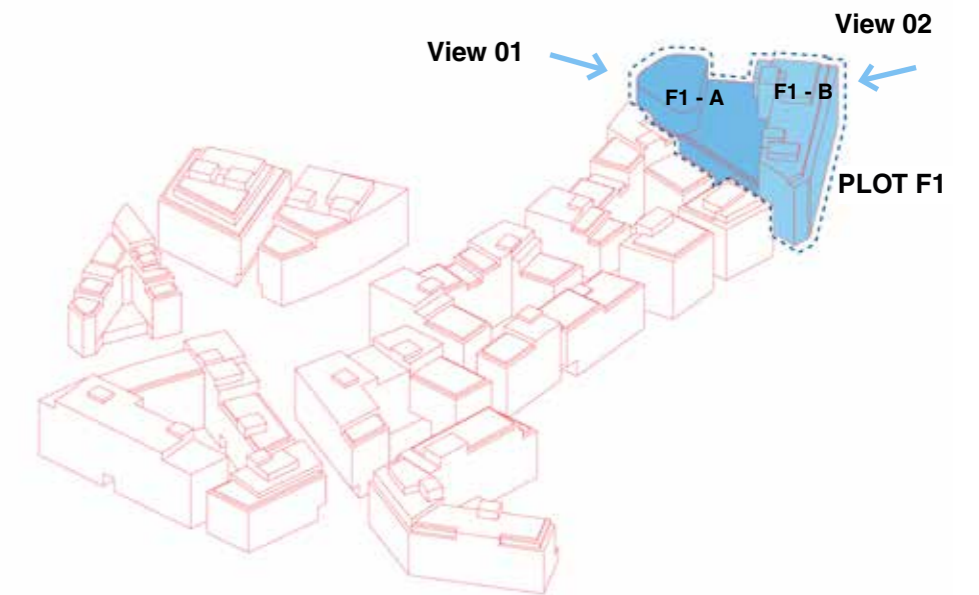

Figure 6.652 Plot parameters key diagram

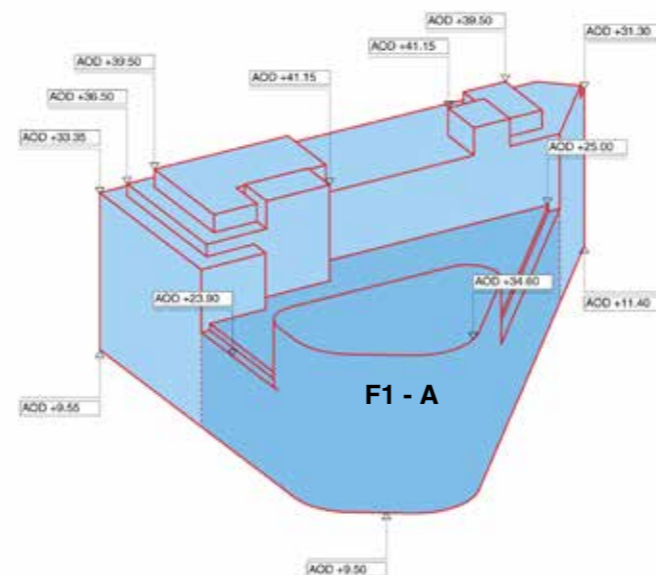

Figure 6.653 Maximum plot parameters diagram - View 01

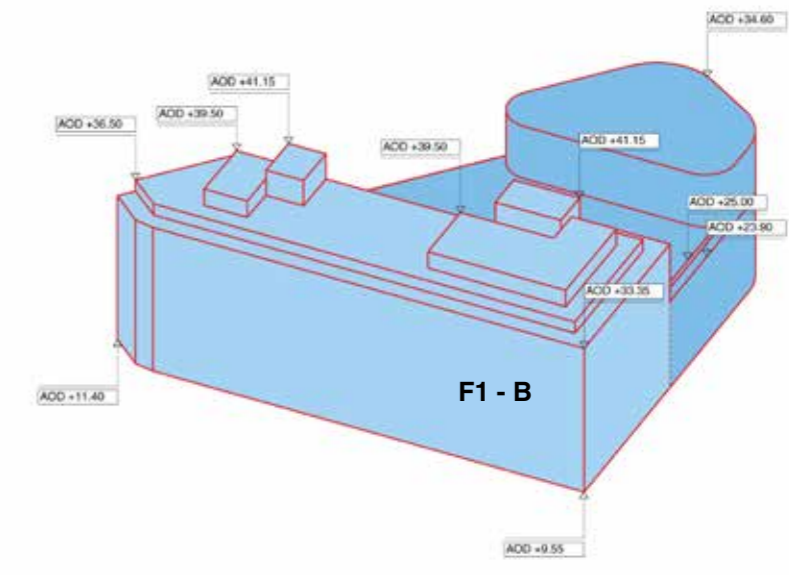

Figure 6.654 Maximum plot parameters diagram - View 02

6. Plot Guide

6.10 Plot F1

6.10.2 Plot Overview

The Leisure Quarter typology can be more adventurous and expressive within the waterfront townscape. Its Castle Street façade will become a new landmark and visible anchor to the southern end of the Framework.

Figure 6.673 demonstrates how Plot F1 is located within the illustrative landscape framework, providing key plot dimensions.

For further details on dimensions of key routes and codes relating to Plot F1's relationship with the public realm please refer to Chapter 4 - Prescription of Future Development - Public Realm and Open Space, of this document set.

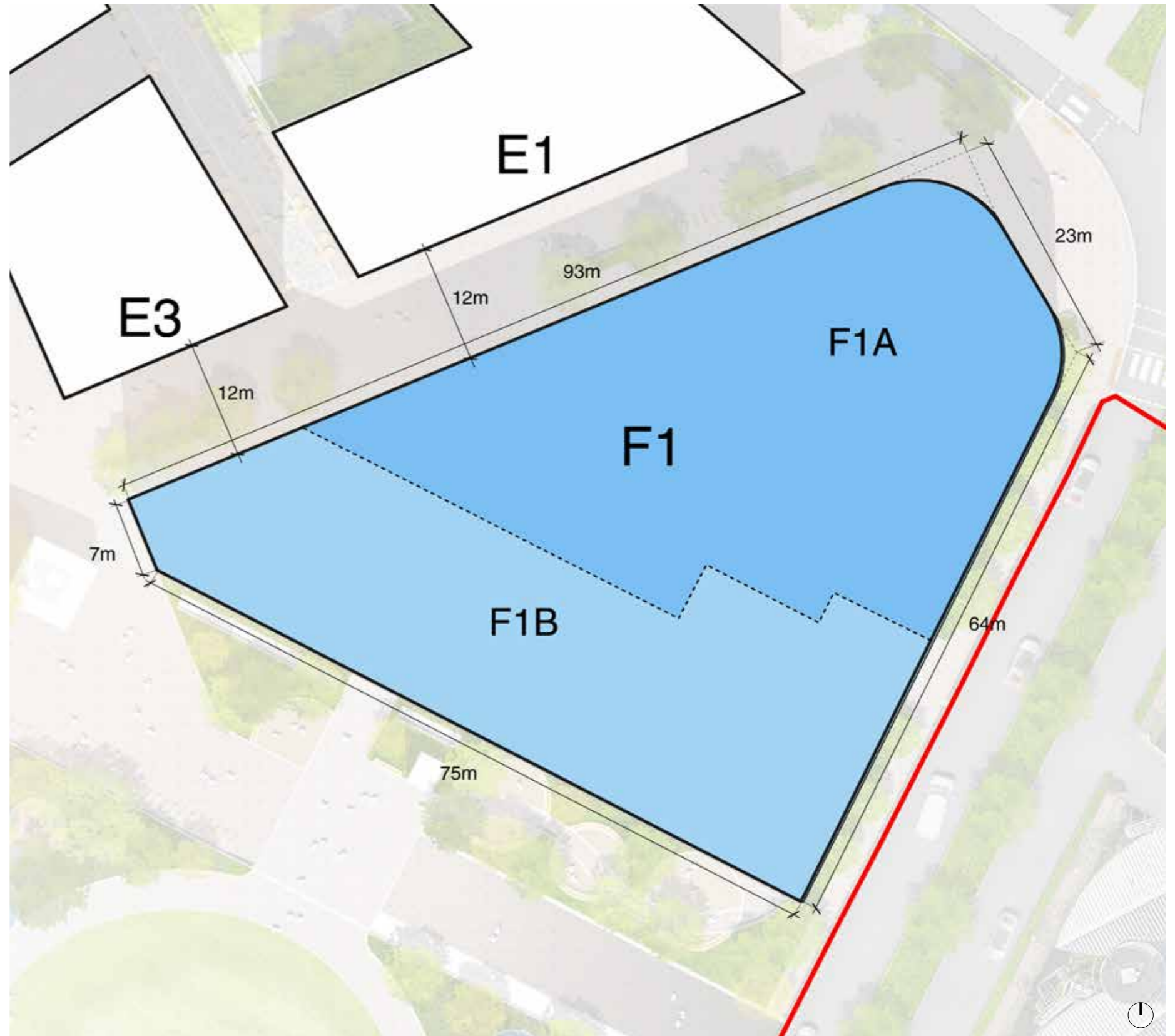





Figure 6.655 Ground floor plan

Legend

-  Plot F1A
-  Plot F1B
-  Adjacent Plots

6. Plot Guide

6.10 Plot F1

6.10.3 General Appearance

F1A AND F1B GENERAL APPEARANCE

The overall approach is to create an elegant, high quality building. The façades should provide a strong frontage, that not only contributing to the identity of the development but holding this critical anchor corner of the framework.

The architectural language of Plot F1A façade should be consistent and wrap around Plot F1 including at low level below the residential use of Plot F1B.

The residential portion Plot F1B should step back with terraces at high level to maximise its seaside and park aspect and incorporate winter gardens or similar vertical features to break up the long elevation.

6.10.3.1 - Plots F1 should be treated as one building formed from two elements: F1A and F1B.

6.10.3.2 - The elevations of Plot F1A should respond appropriately to its gateway setting and compliment the massing and architectural language of the adjacent buildings that form the International Financial Centre.

6.10.3.3 - The elevations to Plot F1B should respond appropriately to their park setting and their expression should complement the architectural language of the adjacent Plot E1 and Castle Quay developments.

6.10.3.4 - The building envelope of F1B must define a clear bottom, middle and top through the architectural expression and treatment of the façade. See figure 6.657.

6.10.3.5 - Consideration must be given to how the building interfaces with the ground and the skyline.

6.10.3.6 - There must be depth and layering in the articulation of the façades to provide a sense of quality in particular at ground level where the bottom of building forms a key edge to the Marina Gardens and Castle Street.

6.10.3.7 - There is an opportunity to showcase the activity within the Leisure Quarter - Leisure component and the façade treatments should allow for transparency whilst respecting the privacy of the user.

6.10.3.8 - Vertical winter gardens or similar architectural features should form part of the F1B plot to reduce the overall long horizontal elevations into distinct vertical portions.

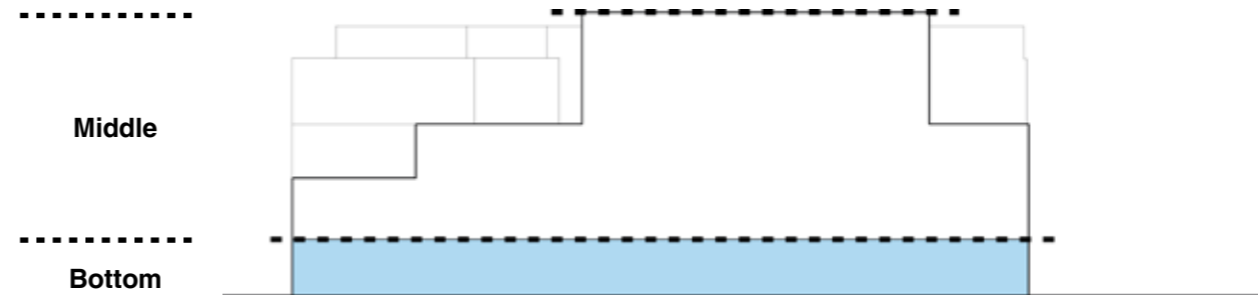

Figure 6.656 Plot F1A - Leisure Centre reference elevation with clearly defined ground level



Figure 6.657 Plot F1B - Leisure Centre residential reference elevation with clearly defined top, middle and bottom

6. Plot Guide

6.10 Plot F1

6.10.4 Wind mitigation

F1A AND F1B OTHER ELEMENTS - WIND MITIGATION

The impact of wind on the public and private realm environment should be mitigated by the incorporation of design features highlighted in the SWSH Visioning Framework Wind and Microclimate Assessment.

6.10.4.1 - Rooftop balustrades and set backs must be considered as indicated in 6.10.6 - Top of the Building.

6.10.4.2 - Inset balconies must be considered as a wind mitigation device as indicated in section 6.10.11 - Balconies and figure 6.662 opposite.

6.10.4.3 - Wind mitigation solutions should be complementary to overall architectural typology design and integrated into the building design.

6.10.4.4 - The design of plot F1 must incorporate wind mitigation measures as identified in the wind chapter of the EIS, or alternative equivalent measures to achieve the same mitigation effect developed and tested through detailed design.

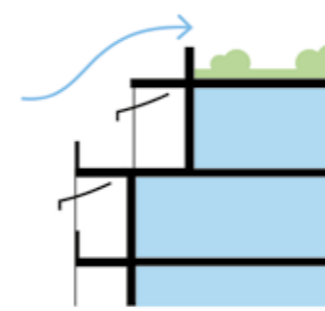

Figure 6.660 Awnings and/or canopy for wind mitigation

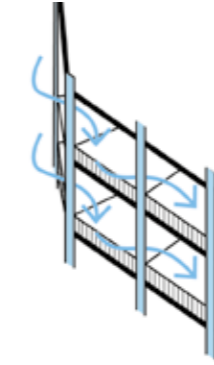

Figure 6.661 Setback upstand for wind mitigation

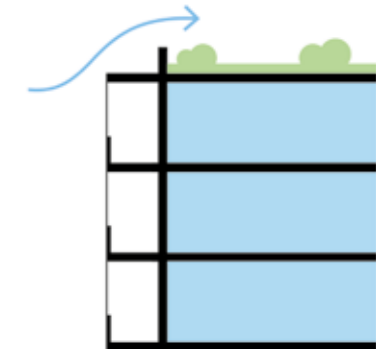

Figure 6.662 Setback upstand for wind mitigation



Figure 6.663 Example of awnings



Figure 6.664 Example of inset balconies



Figure 6.665 Example of 1.1m upstand

6. Plot Guide

6.10 Plot F1

6.10.5 Massing

F1A MASSING

A maximum AOD has been established for Plot F1A. This part of the plot maximises the available area for the building's leisure uses on the north east corner of the plot and then steps down towards the Marina Gardens.

Plot F1A has a more expressive and modern architectural approach with large roof spans to accommodate the leisure uses within. The roofscape is formed from flat planes in preference to more traditional roof profiles.

6.10.5.1 - The ground floor should have additional height to accommodate retail uses. See figure 6.666 below.

6.10.5.2 - Identified roof zone should form a prominent corner facing the Castle Street roundabout. See figure 6.667.

6.10.5.3 - The overall vertical set out of Plot F1A should maximise the internal volume available for multiple leisure uses.

6.10.5.4 - Figure 6.667 identifies the maximum shoulder heights permissible.

Legend

- Maximum plot parameters
- Leisure use portion of the building
- Indicative shaped massing where applicable
- Suggested roof treatment & accessible terrace zones

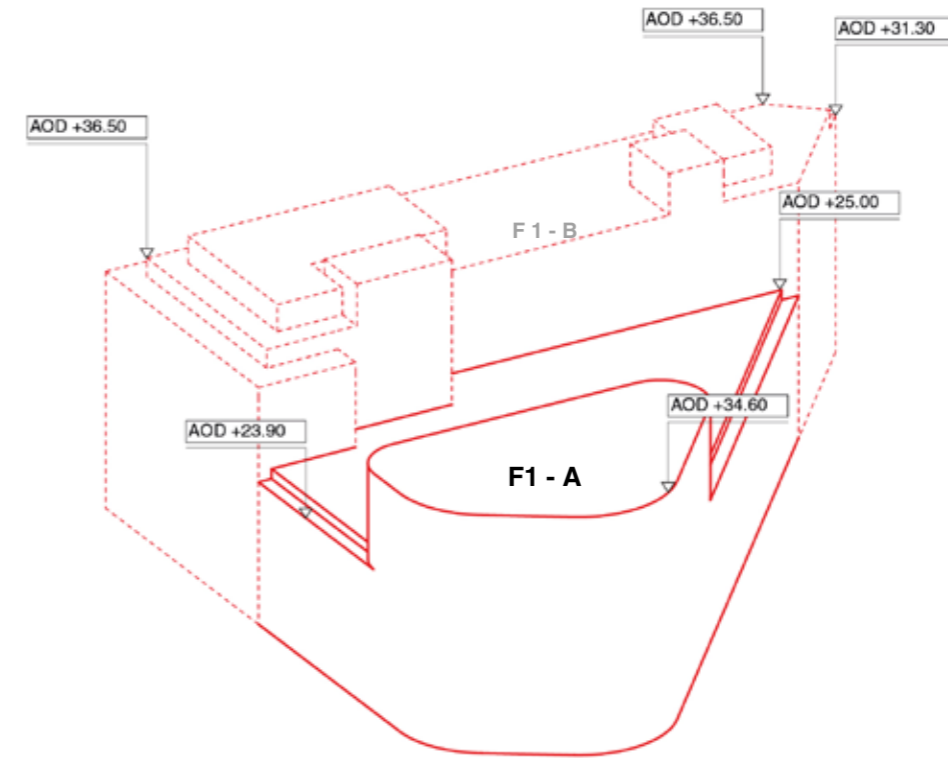

Figure 6.667 Plot F1A Maximum plot parameters showing shoulder heights

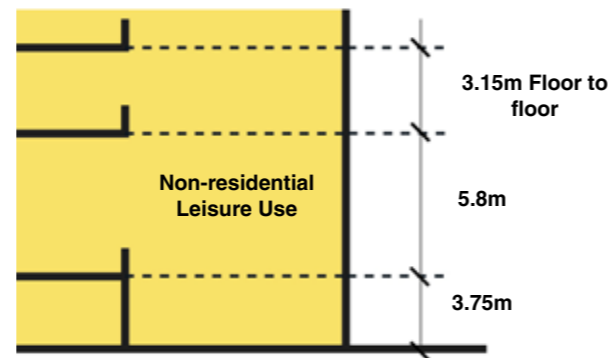

Figure 6.666 Typical floor to floor

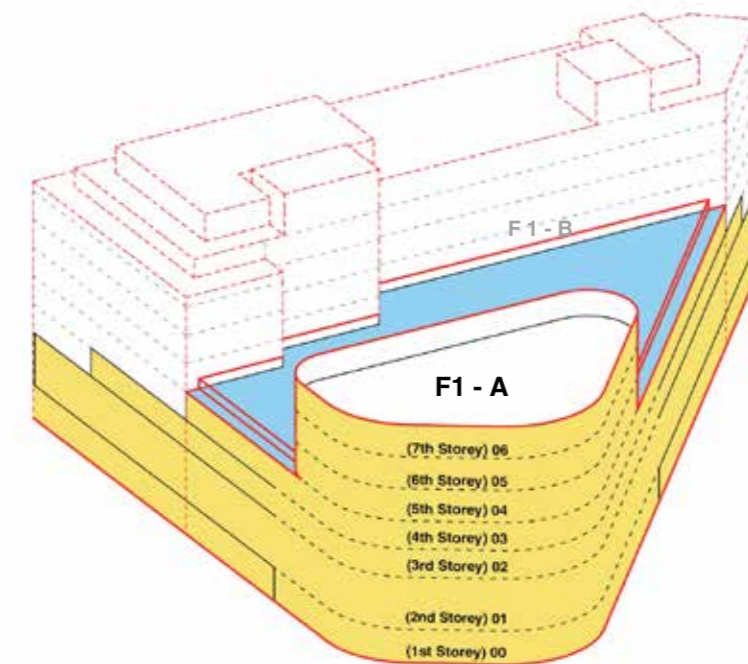

Figure 6.668 Plot F1A Indicative massing set up within maximum plot parameters

6. Plot Guide

6.10 Plot F1

6.10.5 Massing

F1B MASSING

A maximum AOD has been established for Plot F1B. The maximum AOD steps down along its long south west and south east elevations.

The ground level is maximised for leisure and retail uses and forms part of a consistent façade approach that wraps the entire F1 plot.

6.10.5.5 - The ground floor should have additional height to accommodate retail uses. See figure 6.669 below.

6.10.5.6 - Identified roof zone should have a variation in roof profile. See figure 6.689.

6.10.5.7 - The maximum number of storeys permissible for Plot F1B is 6 storeys (ground plus 5) with multiple shoulder heights. See figure 6.671.

6.10.5.8 - Balustrades and privacy screens may project above the shoulder height provided they are contained within the accessible terrace zone as indicated in figure 6.671.

Legend

- Maximum Plot Parameters
- +6m Floor to Floor Base Zone
- Indicative Shaped Massing where applicable
- Suggested Roof Treatment & Accessible Terrace Zones



Figure 6.669 Typical floor to floor

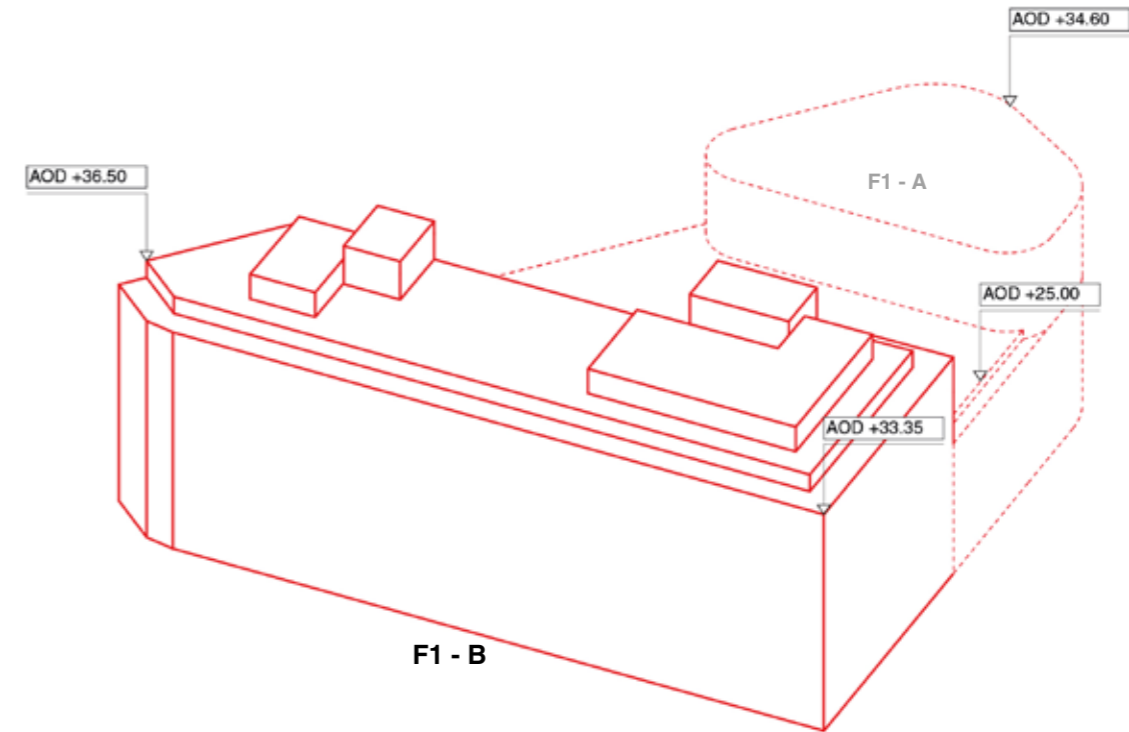

Figure 6.670 Plot F1B Maximum plot parameters showing shoulder heights

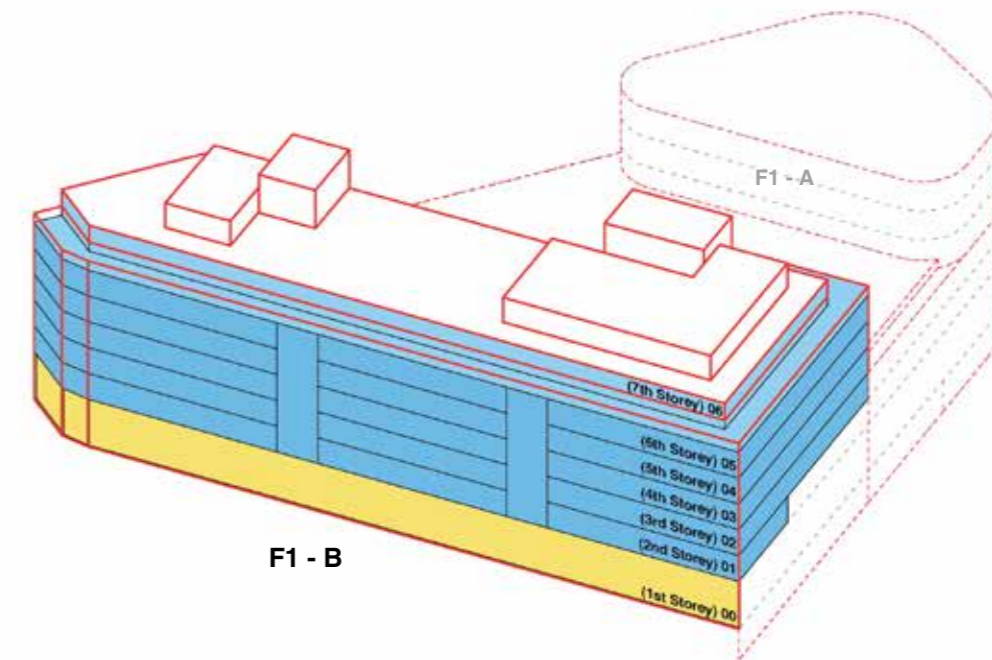

Figure 6.671 Plot F1B Indicative allowable massing set up within maximum plot parameters

6. Plot Guide

6.10 Plot F1

6.10.6 Top of the Building

F1A TOP OF THE BUILDING - ROOF PROFILE

F1A is to have a lower, flat accessible roof for amenity space and an upper flat roofed technical zone for roof top plant.

6.10.6.1 - Accessible terrace zones must be provided and should be set back from the façade by a minimum of 1.5m and have an upstand of minimum 1.1m. See figure 6.673.

6.10.6.2 - The flat roofed technical zone must be hidden from the street by a 3m extension to the façade to form a consistent plant screen. See figure 6.674.

6.10.6.3 - Access for the cleaning, maintenance and potential replacement of façade elements should be allowed for within the design.

6.10.6.4 - Any plant must not align directly to the perimeter of the façade without a concealing façade extension. See figure 6.675.

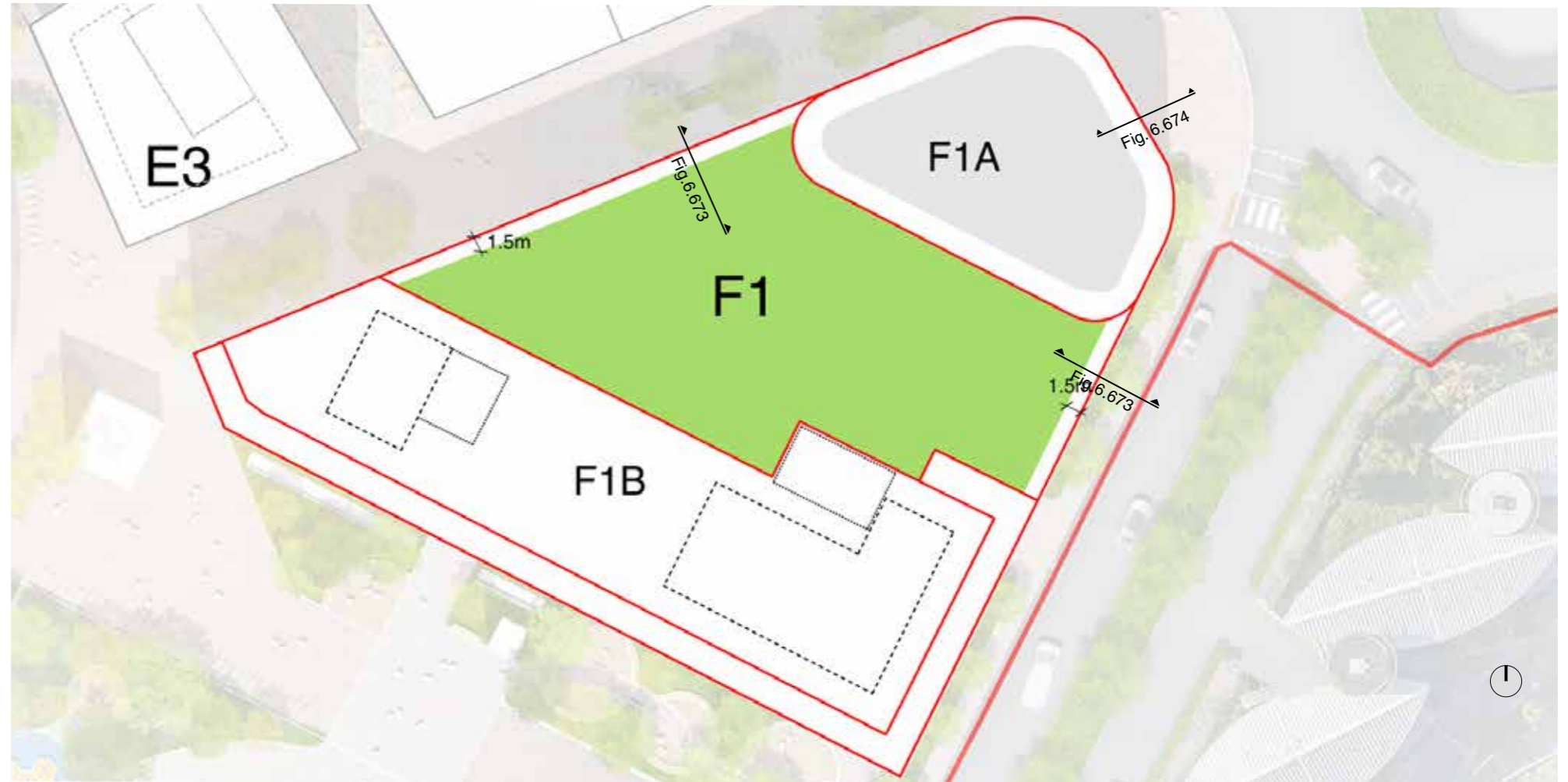

Figure 6.672 Plot F1A Rooftop setback plan

Legend

- Maximum plot parameters
- Indicative suggested massing
- Accessible flat roof terrace
- Non-accessible roof
- Indicatively placed Technical/Plant Zones
- Indicative Core Positions

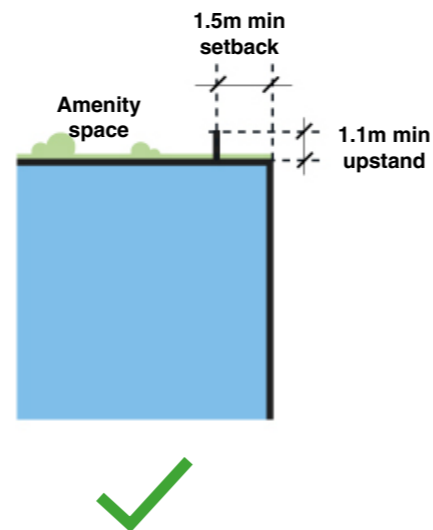

Figure 6.673 Upstand up to max height 1.1m and 1.5m setback

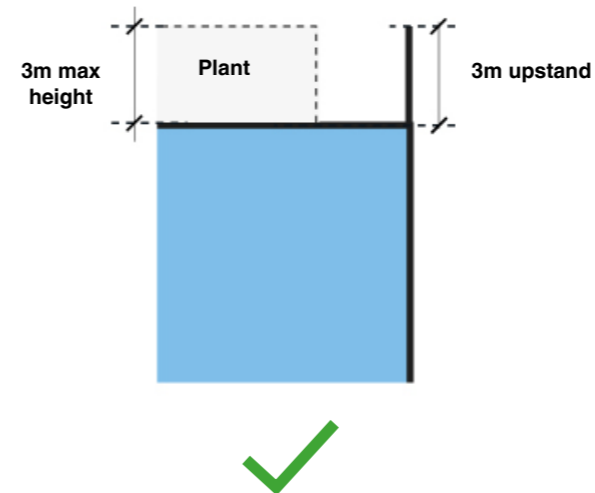

Figure 6.674 3m façade upstand integrated into building envelope to hide plant requirement

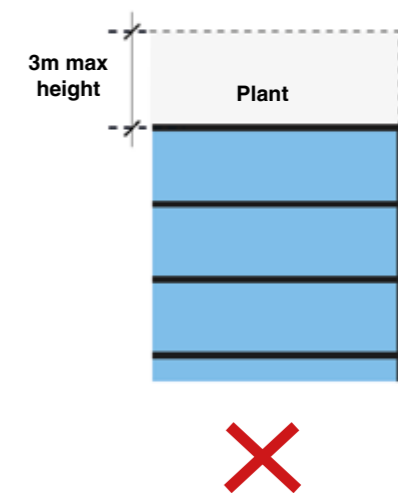

Figure 6.675 No flat roofs or non set back plant

6. Plot Guide

6.10 Plot F1

6.10.6 Top of the Building

F1B TOP OF THE BUILDING - ROOF PROFILE

The residential accommodation in plot F1B steps back at high level to reduce its vertical impact upon the street and to provide accessible flat roof terraces with views out across the Marina Gardens.

6.10.6.5 - The upper level residential accommodation to Plot F1B should be set back a minimum of 3m from the building line. See figure 6.676, 6.678 and 6.679.

6.10.6.6 - Where accessible roof zones align with the façade edge a façade upstand should be used of a maximum height of 1.1m. See figure 6.679.

6.10.6.7 - Perimeter and setback upstands for shelter and guarding should be provided to all accessible roofs.

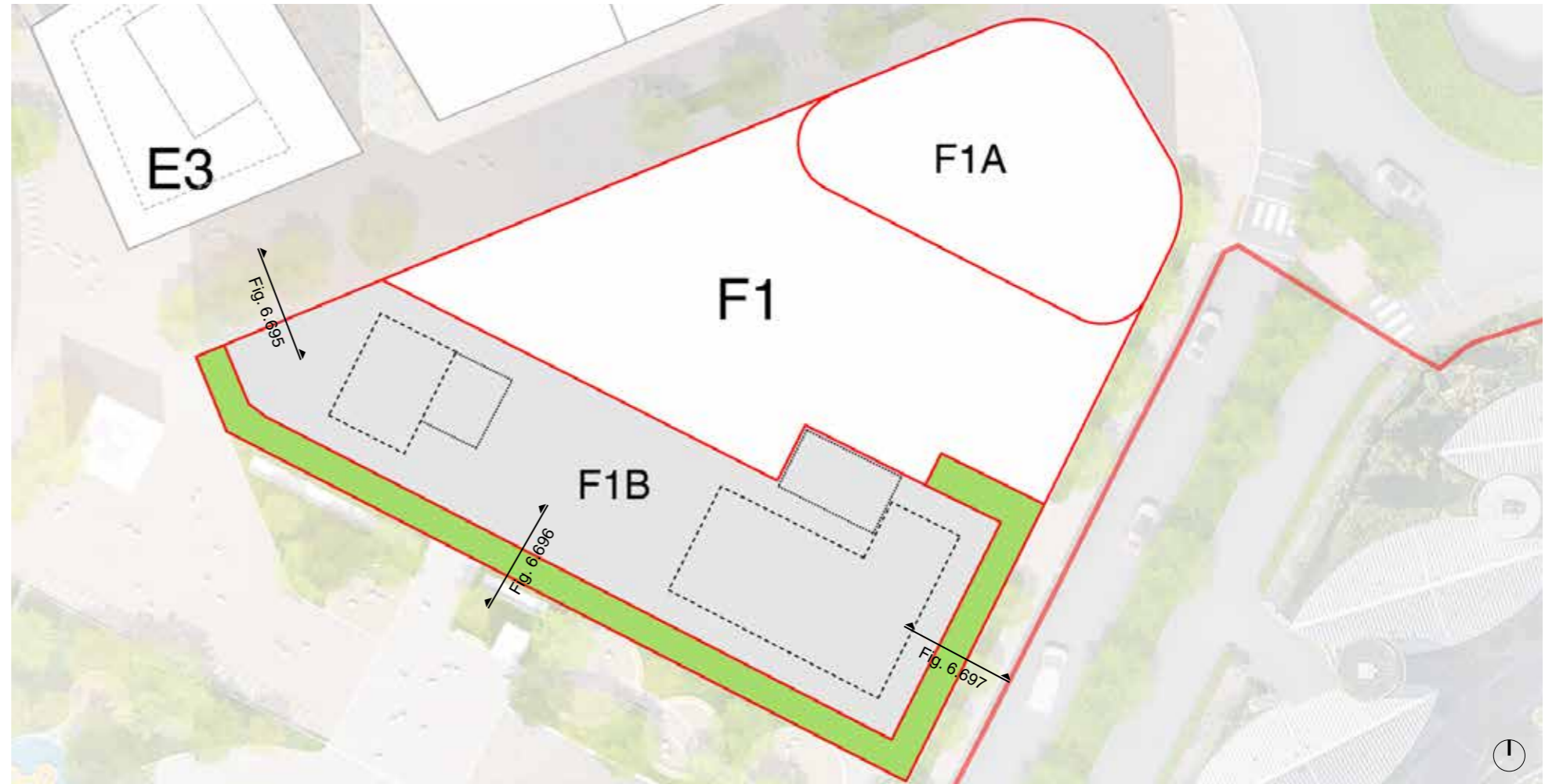

Figure 6.676 Plot F1B Rooftop setback plan

Legend

- Maximum plot parameters
- Indicative suggested massing
- Accessible flat roof terrace
- Non-accessible roof
- Indicatively placed Technical/Plant Zones
- Indicative Core Positions



Figure 6.677 Terraced roofline with 1.1m upstand

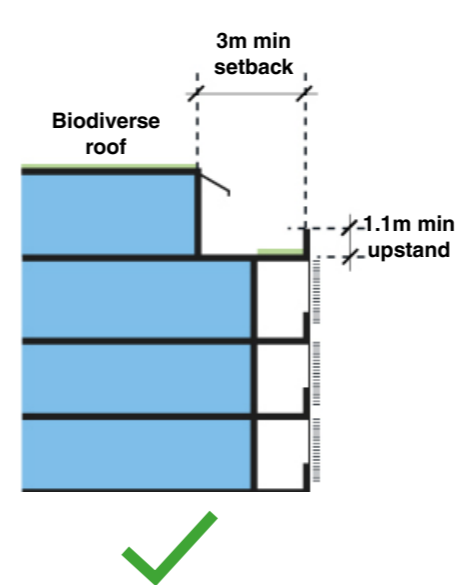

Figure 6.678 Terraced roofline with 1.1m upstand

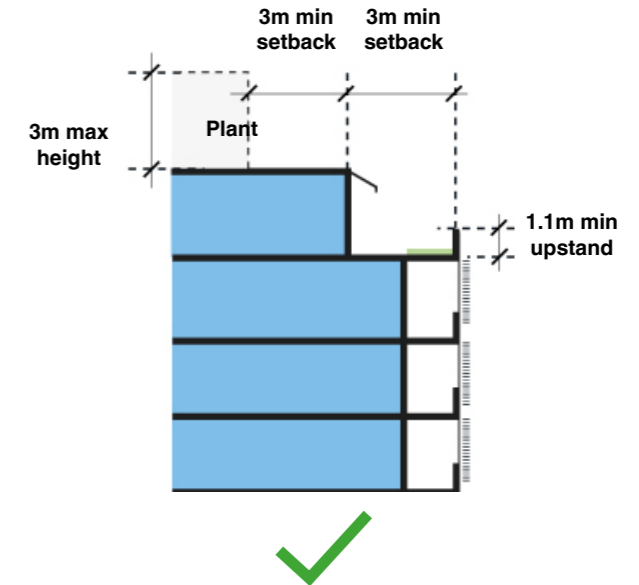

Figure 6.679 Terraced roofline with 1.1m upstand

6. Plot Guide

6.10 Plot F1

6.10.6 Top of the Building

F1A TOP OF THE BUILDING - ROOF TECHNICAL ZONE

A maximum AOD has been established for Plot F1A. The maximum AOD accommodates a roof top technical zone in the north-east corner of the plot.

6.10.6.8 - Any roof top plant is to be located wherever possible within the F1A technical zone and set back 3m from the façade line concealed by a maximum 3m high enclosure designed as an extension to the building's façade.

6.10.6.9 - All core positions, both full storey lobbied access extensions or nominal overruns should be located within the technical zones.

6.10.6.10 - Green or brown roofs should be provided to all non accessible roof areas.

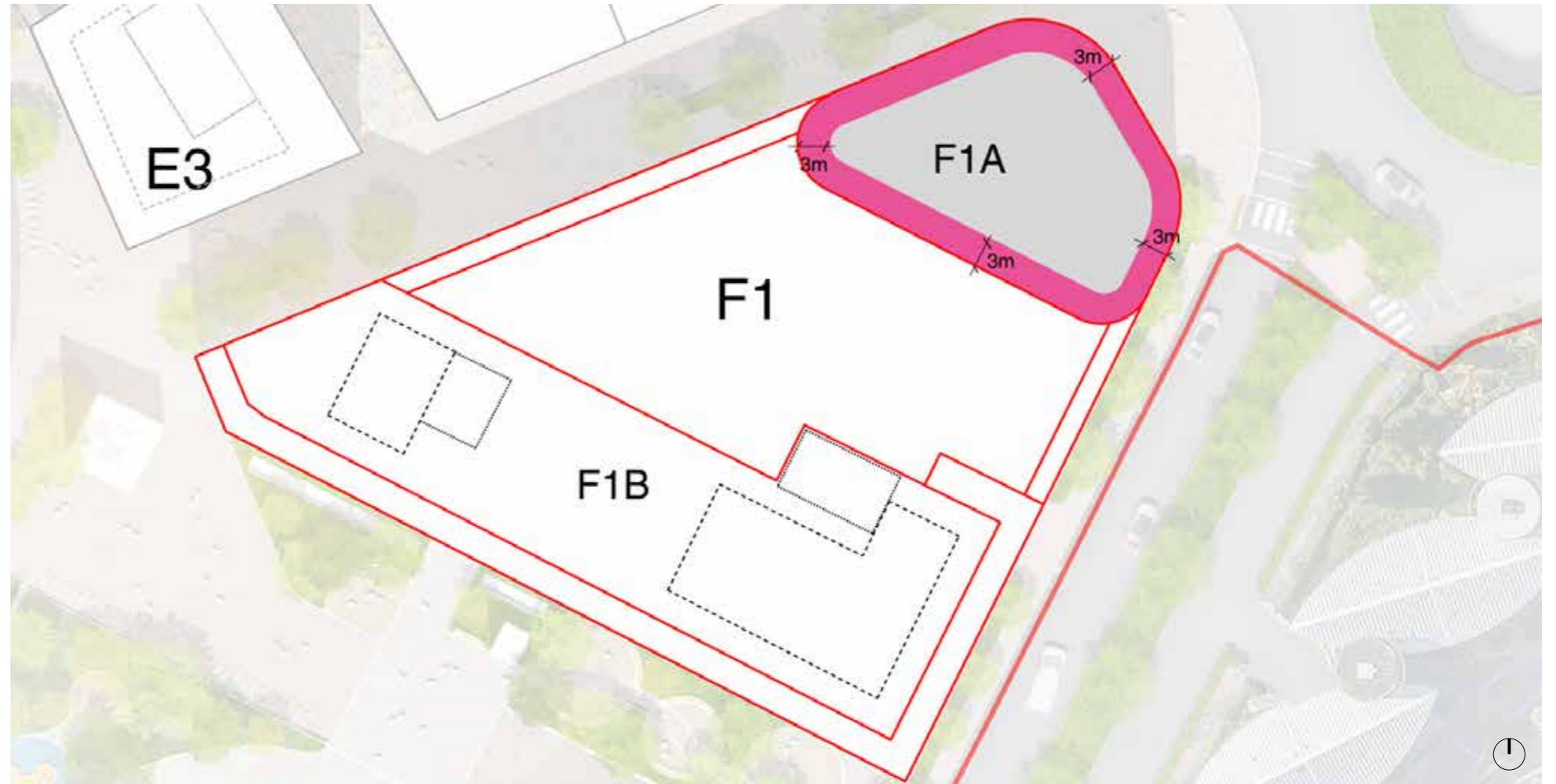

Figure 6.680 Plot F1A Maximum extents and setback roof plan

Legend

- Maximum plot parameters
- Indicative suggested massing
- Set back zone for technical/plant areas (no plant in these areas)
- Maximum extents available for potential technical/plant zone
- Indicatively placed technical/plant zones
- Indicative core positions

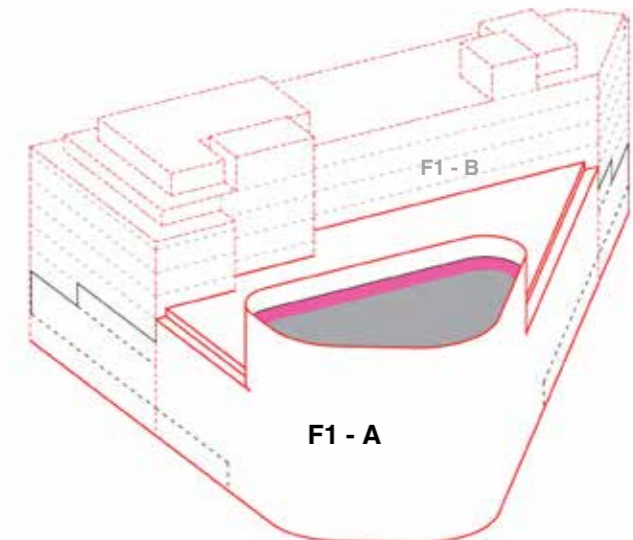

Figure 6.681 Plot F1A Available technical zones within maximum plot parameters

6. Plot Guide

6.10 Plot F1

6.10.6 Top of the Building

F1B TOP OF THE BUILDING - ROOF TECHNICAL ZONE

A maximum AOD has been established for Plot F1B. The maximum AOD accommodates a roof top technical zone set back from the roof edge.

Where not designated for accessible roof zones, a technical/plant zone exists that encompasses the maximum extents for any final arrangements of required plant.

All core positions, both full storey lobbied roof access extensions or nominal overruns, are shown indicatively.

6.10.6.11 - Any plant must be located within the technical zone and set back a minimum 3m from the façade line with a maximum 3m high enclosure. See figure 6.677 and 6.679.

6.10.6.12 - All core positions, both full storey lobbied access extensions or nominal overruns should be located within the technical zones.

6.10.6.13 - Green or brown roofs should be provided to all non accessible roof areas.

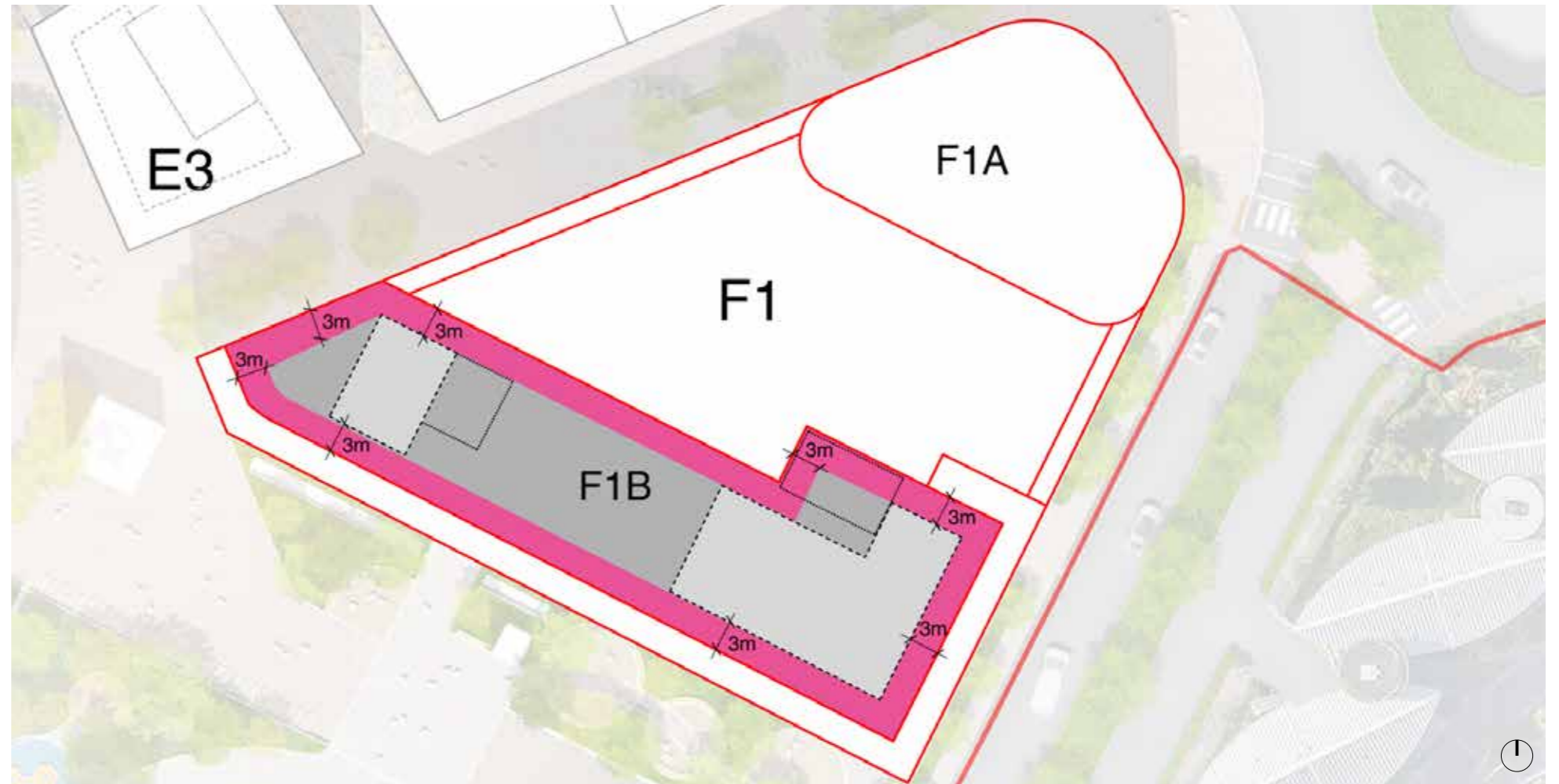

Figure 6.682 Plot F1B Maximum extents and setback roof plan

Legend

- Maximum plot parameters
- Indicative suggested massing
- Set back zone for technical/plant areas (no plant in these areas)
- Maximum extents available for potential technical/plant zone
- Indicatively placed technical/plant zones
- Indicative core positions

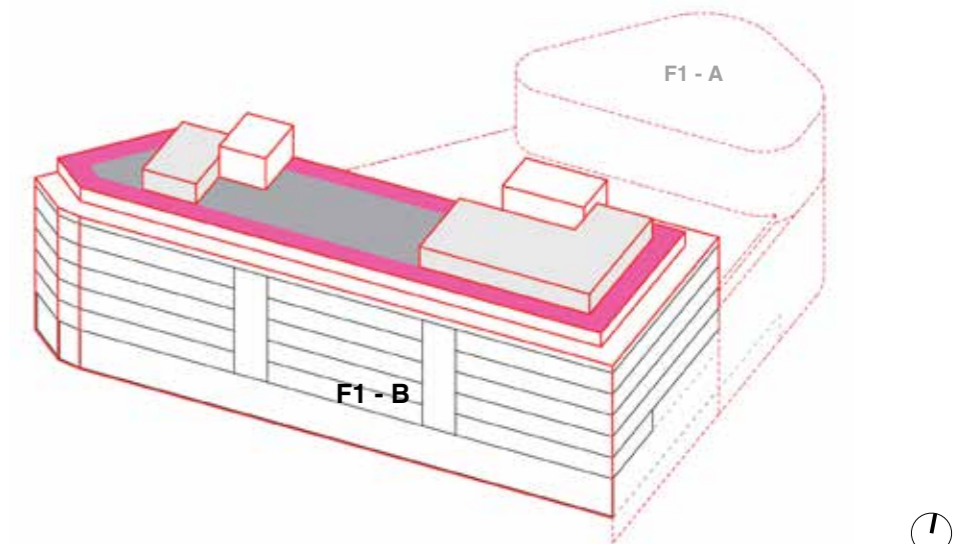

Figure 6.683 Plot F1B Available technical zones within maximum plot parameters

6. Plot Guide

6.10 Plot F1

6.10.7 Middle of the Building

F1A MIDDLE OF THE BUILDING

The overall approach is to create an elegant, high quality building. The façades should provide a strong frontage, contributing to the identity of the typology.

Plot F1A can be more adventurous and expressive and its Castle Street façade will become a new landmark and visible anchor to the southern end of the framework.

Plot F1A utilises a distinct palette of materials that allow for greater transparency and liveliness on the façade of the leisure building. Envisaged as a continuous, seamless wrap around the island plot its façade can incorporate variable porosity/opacity to help display and curate views of the activity within.

6.10.7.1 - The elevations should respond appropriately to their setting and their expression should follow the architectural language of the Leisure Quarter typology.

6.10.7.2 - There must be depth and layering in the articulation of the façades to provide a sense of quality and avoid a uniform monolithic approach.

6.10.7.3 - The design of the façade should respond to the geometry of the plot parameters and avoid large facets to create a contiguous external envelope.

6.10.7.4 - The design of the façade should maximise transparency to show case the leisure activities within and should use obscure or opaque façade techniques to provide privacy and areas of blank façade where required.

6.10.7.5 - Consideration should be given to the design and detailing of the building's superstructure where visible behind the façade.

6.10.7.6 - Consideration should be given to the incorporation of art work, façade lighting and other architectural details to enliven the façade.

6.10.7.7 - Access for the cleaning, maintenance and potential replacement of façade elements should be allowed for within the design.

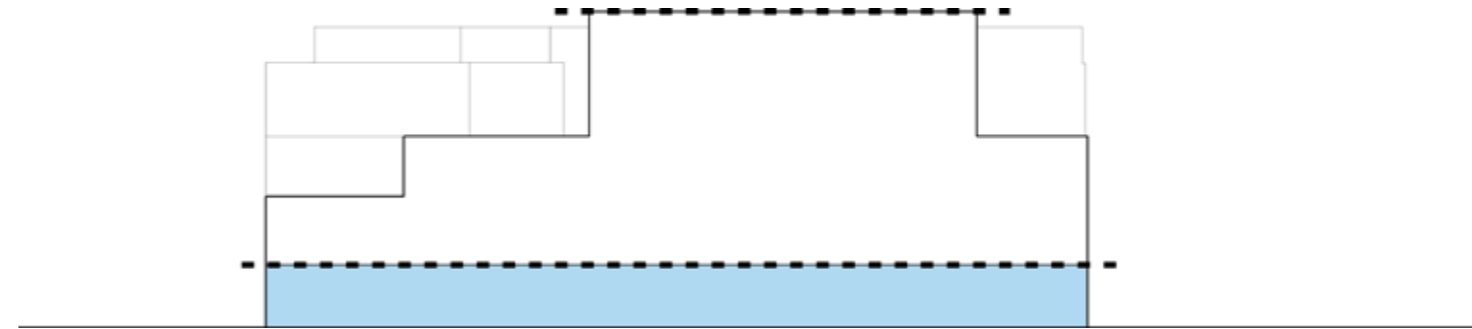

Figure 6.684 Plot F1A Elevation showing stepped profile to external façade

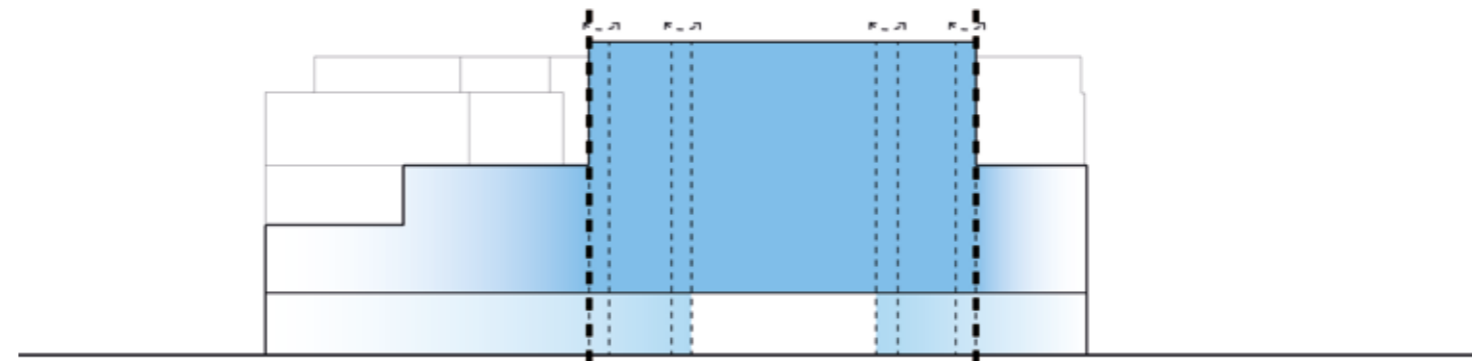

Figure 6.685 Plot F1A Elevation - frontage proportion with proposed entrance

6. Plot Guide

6.10 Plot F1

6.10.7 Middle of the Building

F1B MIDDLE OF THE BUILDING

The overall approach is to create an elegant, high quality residential building that forms the northern edge to the Marina Gardens. The façades should provide a strong frontage, contributing to the identity of the development.

The horizontal parti should have an identifiable top, middle and bottom. The visual impact of long runs of façade should be broken down vertically with winter gardens or similar architectural features to create façade subdivision. The architectural language of each façade between vertical elements should be consistent.

6.10.7.8 - The elevations should respond appropriately to their setting and their expression should follow the architectural language of the Leisure Quarter - Residential component.

6.10.7.9 - There must be depth and layering in the articulation of the façades to provide a sense of quality.

6.10.7.10 - Variety within the detailing to the full height windows and infill to expressed structural frame should be used to create frontage proportion and subdivision to the elevation. See figure 6.687.

6.10.7.11 - Designers should follow the glazing percentage per façade as set out in the Chapter 5.17 Windows.

6.10.7.12 - Architecture details should consider devices that include but not limited to shadow gaps and joint lines to express the unit divisions and rhythms.

6.10.7.13 - Full height windows and infill to expressed structural frame should be used on all elevations.

6.10.7.14 - The design of the vertical winter gardens or similar architectural features should be considered as part of the overall façade design and should extend vertically to the upper level residential accommodation as shown in figure 6.687.



Figure 6.686 Plot F1B Elevation - top, middle, bottom

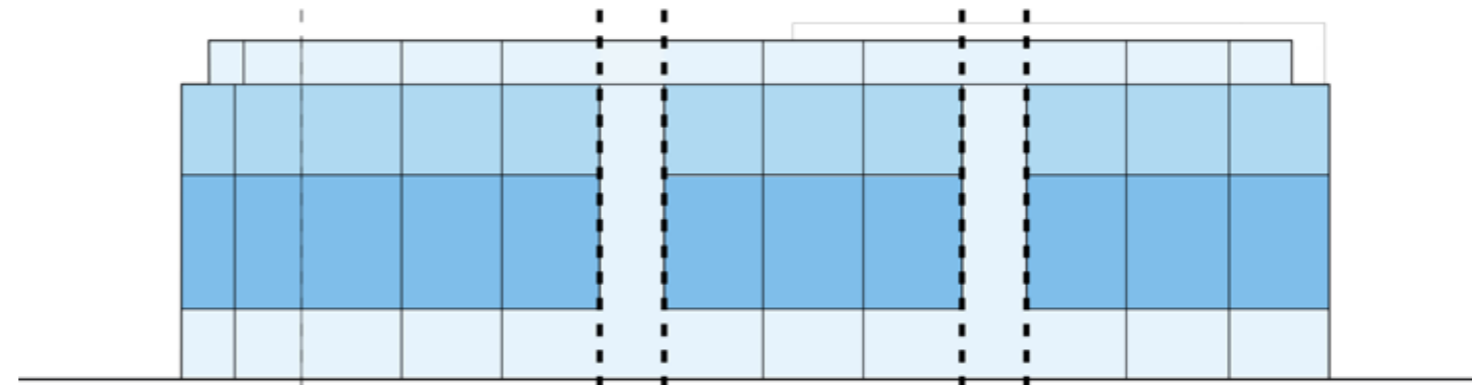

Figure 6.687 Plot F1B Elevation - frontage proportion and street interface - diversity and homogeneity

6. Plot Guide

6.10 Plot F1

6.10.8 Bottom of the Building

F1A AND F1B BOTTOM OF THE BUILDING

There may be a number of entrances required in plots F1A and F1B including one or more commercial/leisure entrances and secondary entrances that include fire escape and/or service entrance(s). The plot is on a gradient and there is a difference in levels between Marina Gardens and La Route du Port Elizabeth. The location of the entrances at ground floor level should take into account any variance in external levels.

All entrances should be carefully integrated into the façade and should be coherent with the façade material expression.

6.10.8.1 - Entrances must have level access even where a change in level occurs.

6.10.8.2 - A minimum of two residential entrance and associated lobby is to be provided within Plot F1B. See figure 6.688.

6.10.8.3 - Residential entrances must be clearly legible through articulation and design and must have a high quality appearance.

6.10.8.4 - Residential lobbies to Plot F1B are to be set in from street line with mainly glazed frontages with options for further solid/inset materials. Where required glazed entrance residential lobbies should have either integrated revolving doors or draft lobbies. See figure 6.690.

6.10.8.5 - The main entrances to the Leisure Quarter must be clearly legible through articulation and design and must have a high quality appearance commensurate with a public building.

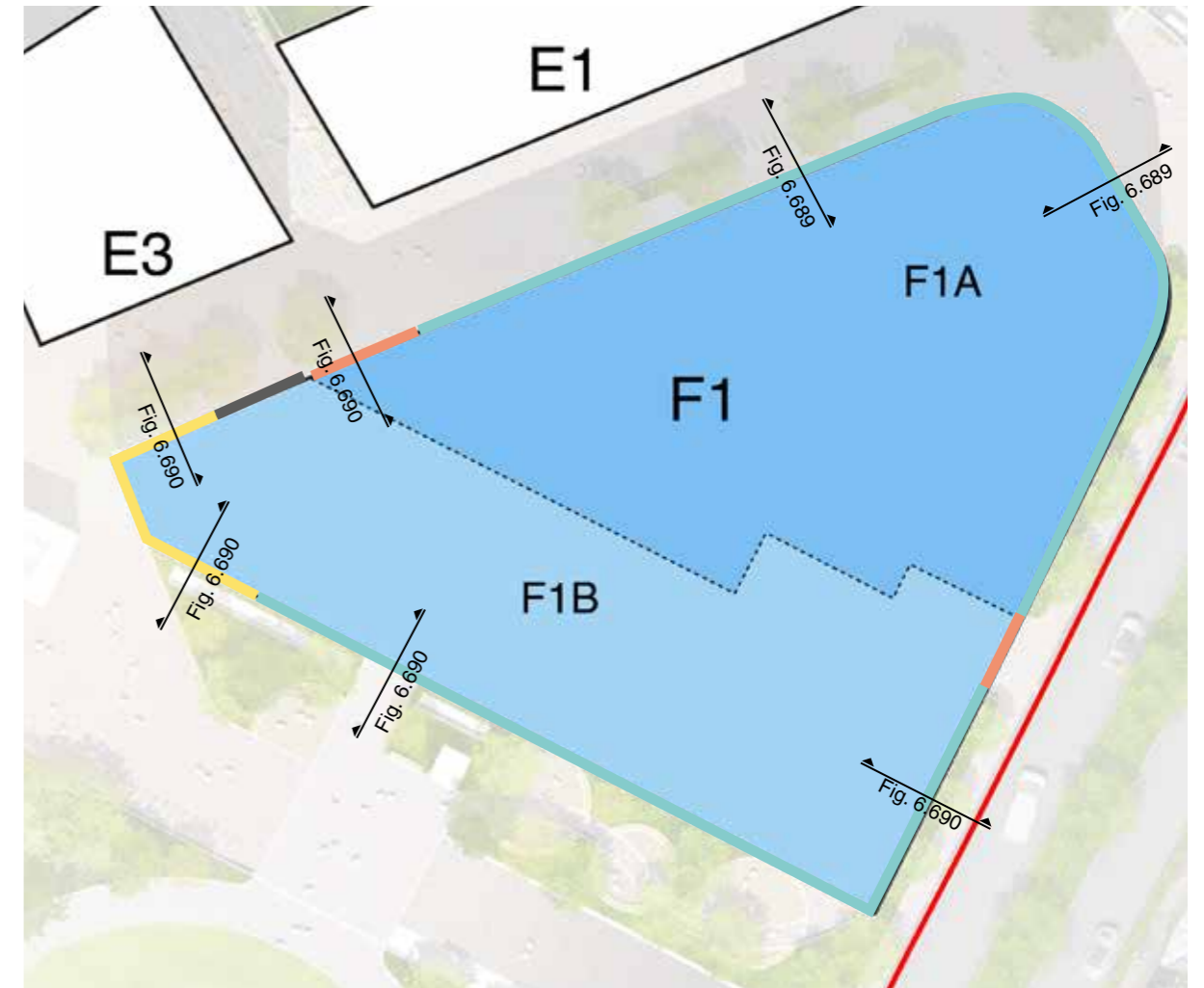

Figure 6.688 Plot F1 bottom of building suggested condition

Legend

- Zone for residential entrances
- Zone for leisure entrances
- Zone for food and beverage entrances
- Zone for basement entrances

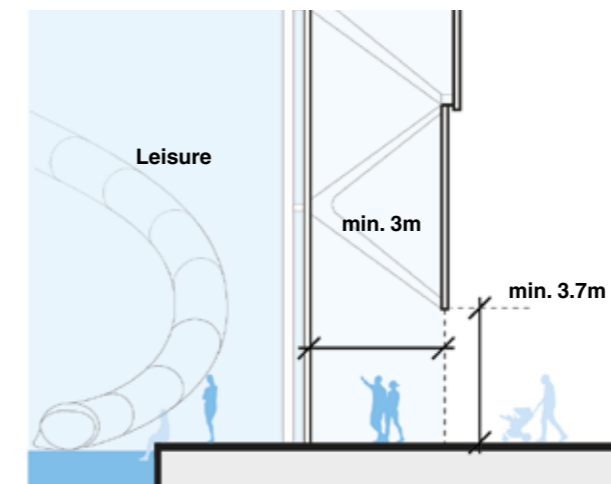

Figure 6.689 Illustrative set up for a suggested design for the leisure entrance

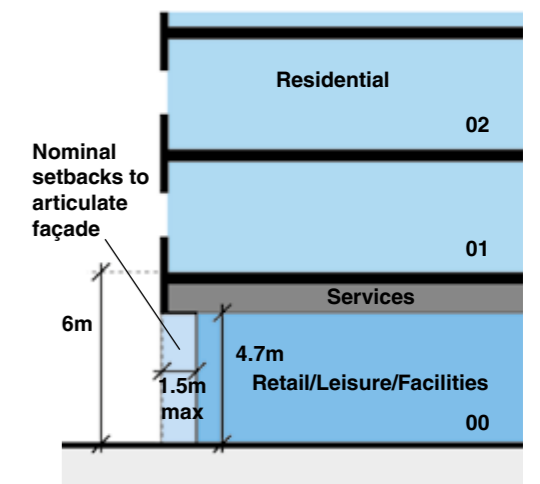

Figure 6.690 Nominal setback condition

6. Plot Guide

6.10 Plot F1

6.10.8 Bottom of Building

F1A AND F1B BOTTOM OF BUILDING

Plot F1A utilises a distinct palette of materials that allow for greater transparency and liveliness on the façade of the leisure building. Envisaged as a continuous, seamless wrap around the island plot its street frontages can incorporate variable porosity/opacity to help display and curate views of the activity within. Signage and graphics should be complimentary to the overall architectural façade treatment.

6.10.8.6 - Flush or nominally set back ground façade conditions should exist across Plots F1A and F1B.

6.10.8.7 - The bottom of the building should have a consistent architectural language and materiality (see Chapter 5.16 Bottom of building).

6.10.8.8 - The design of the ground level frontage should maximise transparency to show case the leisure activities within and use obscure or opaque façade techniques to provide privacy and areas of blank façade where required.

6.10.8.9 - Where façade at ground faces La Route du Port Elizabeth, consideration should be taken in providing a seamless yet engaging façade, especially where no leisure function can be observed behind.

6.10.8.10 - Entrances to both the Leisure and Residential components of the Leisure Quarter should have either integrated revolving doors or wind lobbies where required.

6.10.8.11 - Any entrances along La Route du Port Elizabeth should accommodate any differences between the external street levels and internal floor levels. See figure 6.692.

Legend

- Zone for material variance and signage
- Zone for residential entrance specific detail set up
- Suggested essential insets of nominal depth per use
- Suggested selectively transparent inner enclosure
- Suggested inner circulation zone (leading to lobby and ticket hall)
- Suggested automatic sliding doors

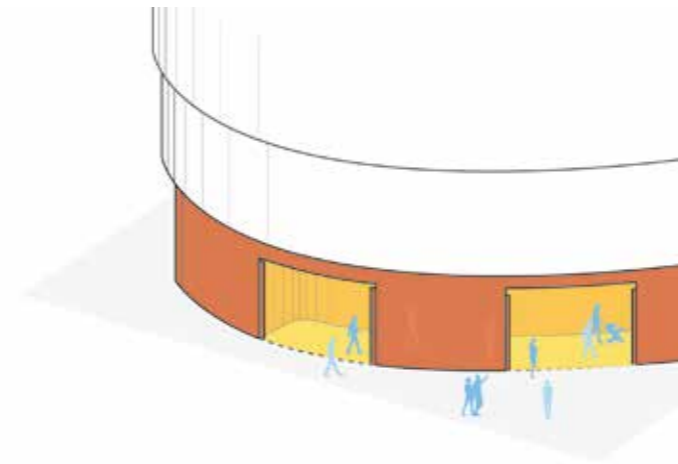

Figure 6.691 Illustrative example of a Leisure Quarter - Leisure entrance

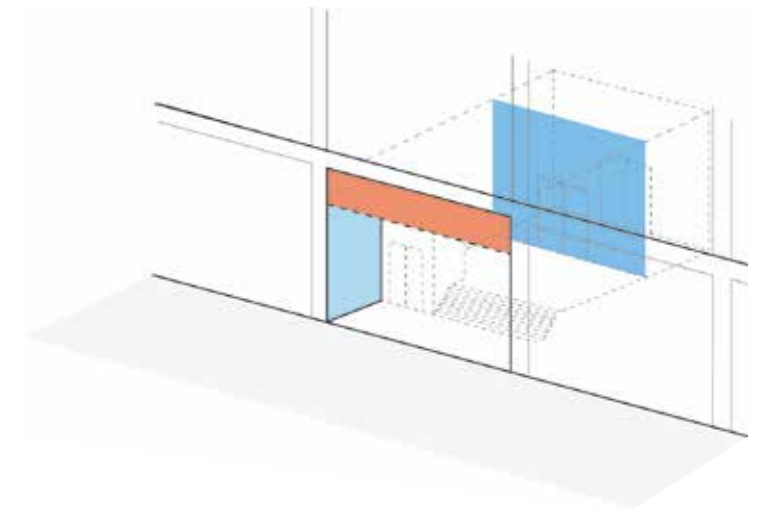

Figure 6.692 Illustrative example of a Leisure Quarter - Residential entrance



Figure 6.693 Illustrative example of a layered entrance integrated to variable opacity of cladding and lighting



Figure 6.694 Illustrative example of integrated lift and stair to entrance circulation of residential block to accommodate level changes

6. Plot Guide

6.10 Plot F1

6.10.9 Adjacent Buildings

F1A AND F1B BUILDING ADJACENCIES

Plot F1A is located within close proximity to plot E1. Plot F1B forms the northern edge to the Marina Gardens and is in close proximity to Plot E3.

6.10.9.1 - Consideration for balcony placement and openings should be taken to minimise proximity issues where façades face onto closely adjacent plots such as E1 and E3, see also Chapter 6.10.11 for further guidance.

6.10.9.2 - Consideration of window placement and directional framing should be taken where plots are directly adjacent to one another to minimise overlooking, see Chapter - 5.18 Proximity and Overlooking.

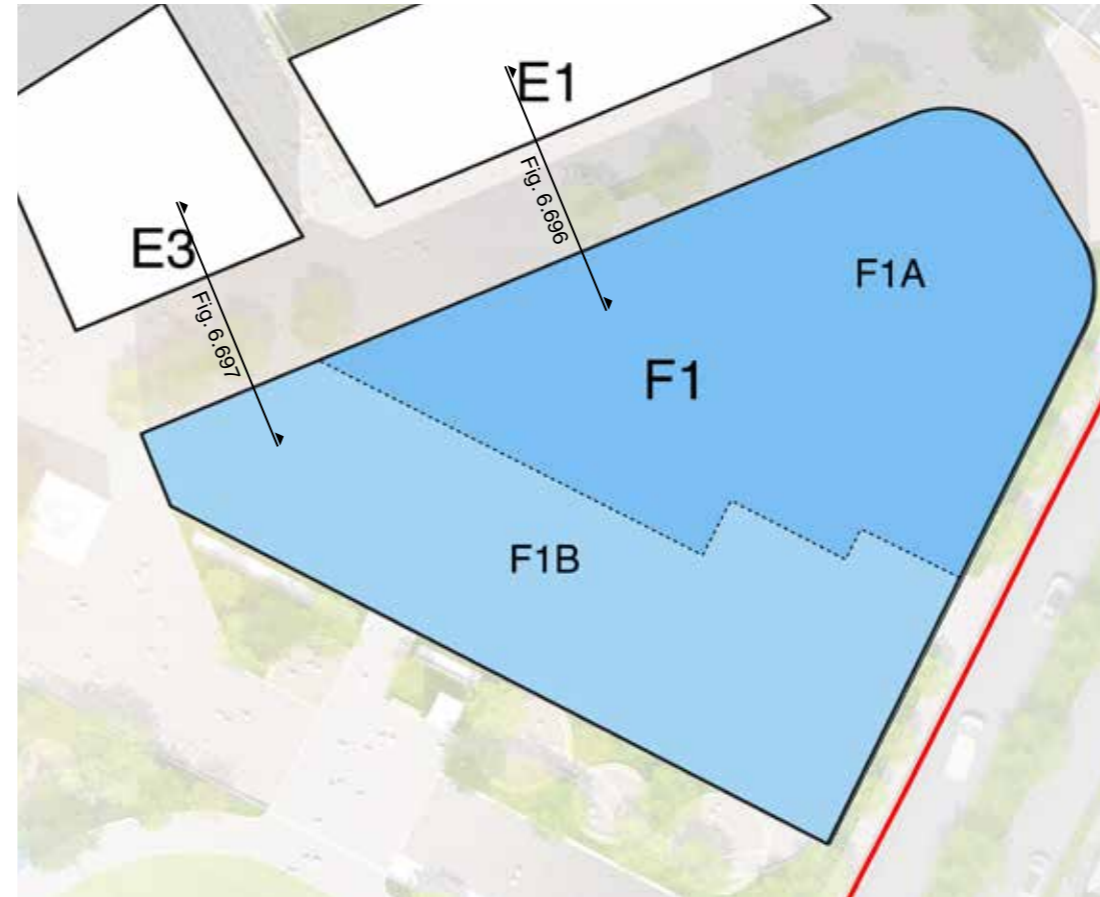

Figure 6.695 Plot F1A Building adjacencies key plan

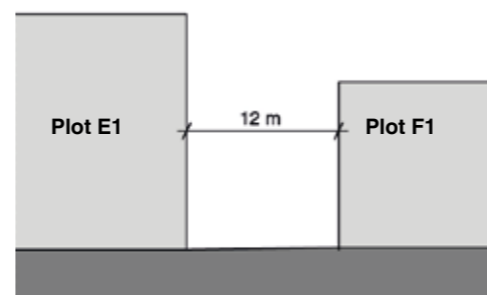

Figure 6.696 Building adjacency between E1 and F1



Figure 6.697 Building adjacency between E3 and F1

6. Plot Guide

6.10 Plot F1

6.10.10 Openings

F1A OPENINGS IN THE FAÇADE

Designers should pay careful attention to the placement of openings across the façade. Whilst different opening compositions should be considered, they should also be as part of a coherent façade openings strategy.

Plot F1A has a continuous, seamless high performance wrap with a variable porosity/opacity to help display and curate views of the activity within. It is assumed that the majority of the façade will be sealed to maintain climatic control within the active leisure environments. Where openings are required or openings are required for windows or activated vents are then these should be coordinate within the overall façade approach.

6.10.10.1 - The façade to F1B should be designed as a continuous, seamless wrap around the island plot and its street frontages can incorporate variable porosity/opacity to help display and curate views of the activity within as figure 6.698.

6.10.10.2 - Windows and opening vents should be complimentary to the façade system and design as figure 6.699.

6.10.10.3 - Consideration should be given to the incorporation of art work, façade lighting and other architectural details to enliven the façade at ground level as figure 6.700.

6.10.10.4 - Areas for building services should be treated as screened openings coordinated with the colour and materiality of the façade materials (e.g. Louvres/ventilation grills), for a coherent elevation strategy. These should be minimised on principal elevations wherever possible.

6.10.10.5 - Consideration for access for the cleaning, maintenance and potential replacement of all elements should be given when designing openings.

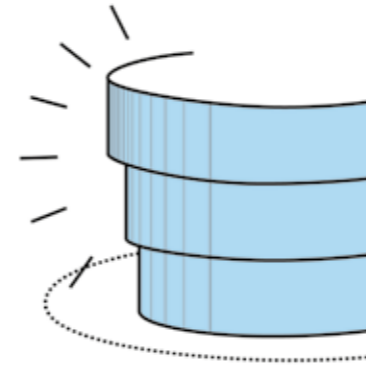

Figure 6.698 Seamless high performance wrap

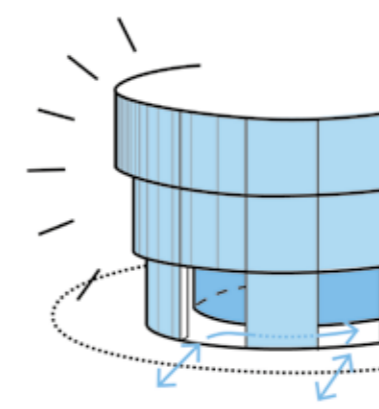

Figure 6.699 Openings coordinated with overall façade approach

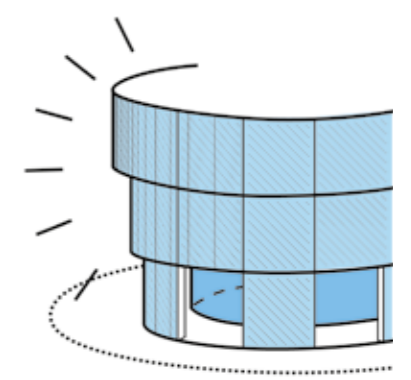

Figure 6.700 Suggested kinetic/perforated/ lit façade for visual interest

6. Plot Guide

6.10 Plot F1

6.10.10 Openings

F1B OPENINGS IN THE FAÇADE

Designers should pay careful attention to the placement of openings across the façade. Whilst different opening compositions should be considered, they should also be as part of a coherent façade openings strategy.

6.10.10.6 - Windows should form consistent patterns across the façade, but allow for variation within the overall grid. See figures 6.701 and 6.702.

6.10.10.7 - Dormer and mansard features should not to be used on plot F1. See figures 6.703 and 6.704.

6.10.10.8 - All façades should have a considered level of detail to the window openings - depth, reveals and framing, to give a high quality layered result. See figure 6.707.

6.10.10.9 - Inset balconies should be integrated into the expressed structural grid. See figure 6.702.

6.10.10.10 - Areas for building services should be treated as screened openings with colour and materiality to work with façade materials (e.g. Louvres/ventilation grills), for a coherent elevation strategy. These should be minimised on principal elevations wherever possible.

6.10.10.11 - Consideration for access for the cleaning, maintenance and potential replacement of window elements should be incorporated into the design.

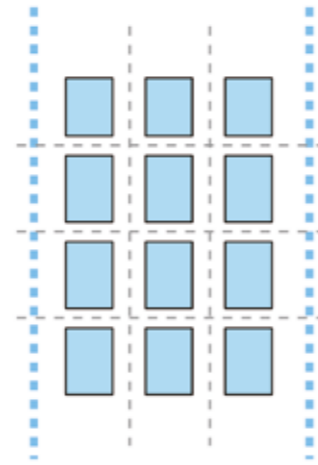

Figure 6.701 Gridded window layout

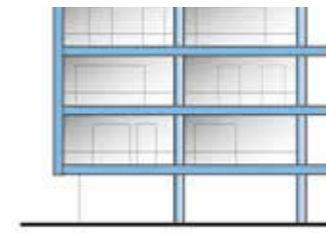

Figure 6.702 Inset balconies and structure to a regular grid



Figure 6.703 Double mansard dormer windows

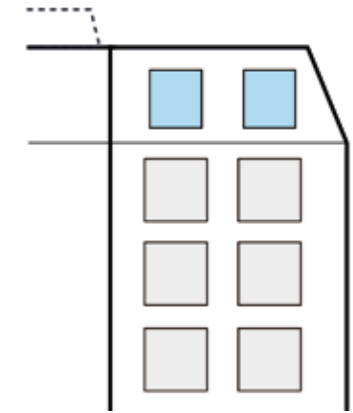

Figure 6.704 Single mansard dormer windows



Figure 6.705 Single mansard/pitched inhabited roof



Figure 6.706 Double mansard/pitched inhabited roof

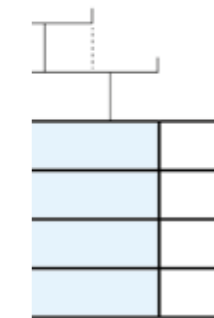

Figure 6.707 Inset balconies with shading screens

6. Plot Guide

6.10 Plot F1

6.10.11 Balconies

F1B BALCONY CONDITIONS

The balcony arrangement should be carefully positioned as part of the overall composition of the façade.

Consideration of the balcony location should be taken into account in order to avoid overlooking and proximity issues.

Consideration of the balcony location within the façade should be taken into account to avoid unnecessary shading to the rooms below.

It is suggested that there is a façade variation of 70% inset - 30% Juliet across F1B.

6.10.11.1 - Inset and Juliet balconies should only be provided to the residential portion of the Leisure Quarter.

6.10.11.2 - Balustrades can vary in design but must be complementary to the façade design.

6.10.11.3 - A minimum balustrade height of 1.1m must be provided for all balconies.

6.10.11.4 - Horizontally barred balustrades must not be used permitted as they are a climbing hazard.

6.10.11.5 - There should be variation in colour and material of balustrading as well as specific highlighting materials to the returns and soffits of any inset balconies for visual interest and variation across façades.

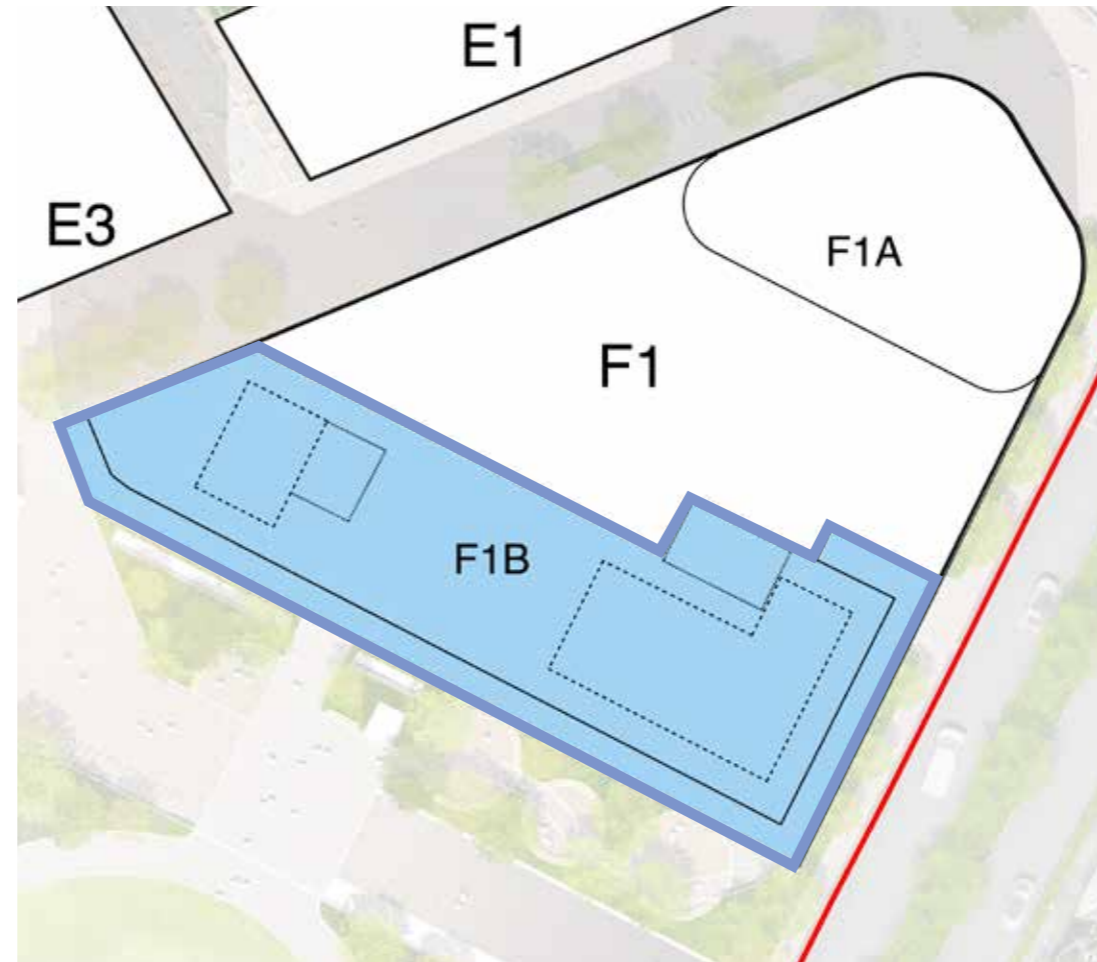

Figure 6.708 Plot F1B balcony condition key plan

Legend

- - - Building boundary
- Inset & Juliet balconies

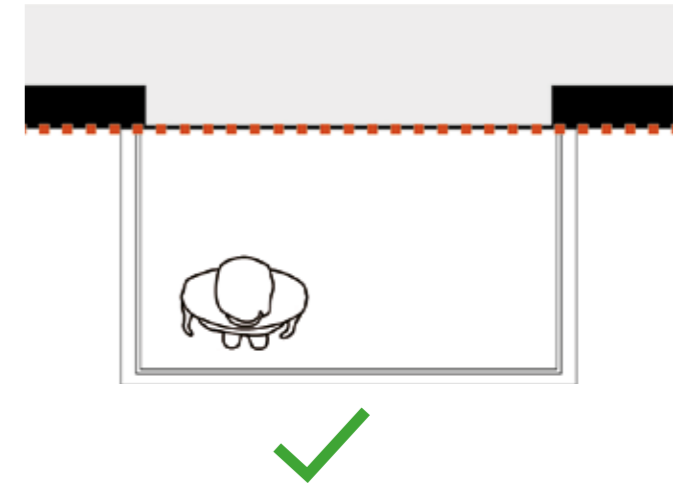

Figure 6.709 Proud balcony condition

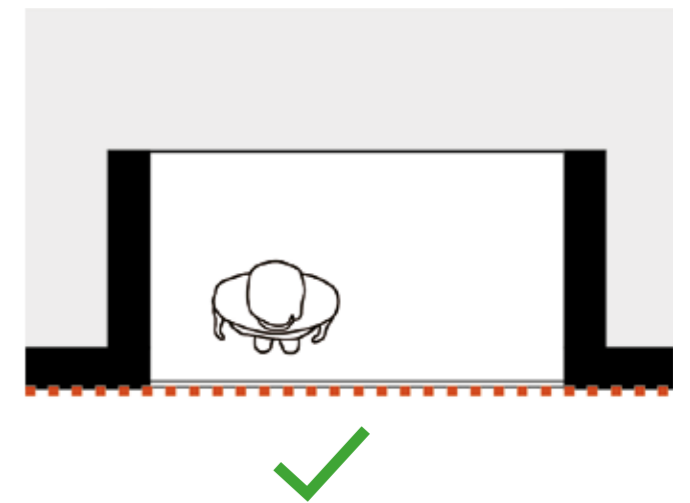

Figure 6.710 Inset balcony condition

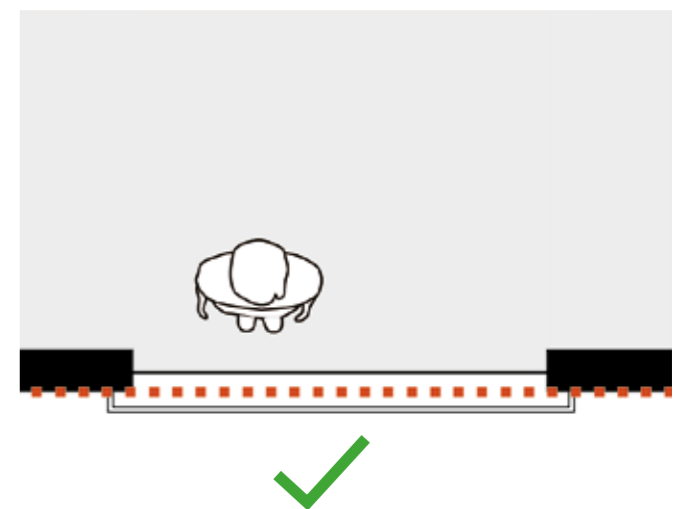

Figure 6.711 Juliet balcony condition

6. Plot Guide

6.10 Plot F1

6.10.12 Material Appearance

Hard-wearing and long-life quality materials should be chosen - to an overall palette that takes inspiration from the existing local colours and materials, with the introduction of complimentary new or equivalent material types where appropriate.

Care should be taken when sourcing all materials to ensure minimum environmental impact and the sustainable credentials of the source and the materials lifecycle, see Chapter 6.9 Waterman's Sustainability Statement for further guidance.

F1A MATERIAL APPEARANCE

Plot F1A requires a distinct palette of materials that allow for greater transparency and liveliness on the façade of the leisure building. Envisaged as a continuous, seamless wrap around the island plot its façade can incorporate variable porosity/opacity to help display and curate views of the activity within.

The secondary material palette for areas of Plot F1A could include various 'infill' material options to add life, vibrancy and character to the Leisure Quarter typology.

The tertiary material palette of the F1A Leisure Quarter - Leisure portion of Plot F1 refers to the layer of artwork textural treatment that can be applied to any of the primary or secondary palette materials and could include various types of texture, relief, porosity and kinetic treatments.

6.10.12.1 - The primary material palette should utilise a high quality façade system incorporating high performance glazing and opportunities for innovative transparent and translucent materials.

6.10.12.2 - Material selection should consider material used on neighbouring plot façades.

6.10.12.3 - Promotion of the use of materials that incorporate recycled content and procuring products with a low environmental impact should be a priority when choosing materials. For further guidance see Chapter 6.9 of SWSH Visioning Framework Sustainability Statement.

6.10.12.4 - The secondary material palette should be complementary to the primary composition.

6.10.12.5 - Anodised, pre-oxidised and/or sealed/coated pre-weathered metals should be used.

6.10.12.6 - Ceramics, terracotta, GRCs and other hard-wearing cementitious cladding materials should be used.

6.10.12.7 - The tertiary material palette should be complementary to the primary composition.

6.10.12.8 - Textural treatments that can be applied to any of the primary or secondary palette materials should include various types of patterned textures, relief, porosity arrangements of perforations to material or of specific elements and includes kinetic elements and/or treatments.

6.10.12.9 - All materials chosen should be hard wearing and must age well in a maritime environment.

6.10.12.10 - Colours for any framing, metalwork and other architectural and design features must be complementary to the materials used on the rest of the building.

6.10.12.11 - Highly reflective or 'mirror like' glazing must not be used on any façade.

F1B MATERIAL APPEARANCE

The primary material palette for all façades of the F1B Leisure Quarter - Residential portion of Plot F1 should be drawn from both the St Helier local stone types in conjunction with a mix of re-constituted stone and concrete/GRC 'frame and infill' approaches in keeping with a high quality façade as part of the more lively and exuberant Leisure Quarter complex.

The secondary material palette for areas of roof of the F1B Leisure Quarter - Residential portion of Plot F1 should include various 'infill' material options to add life, vibrancy and character.

The tertiary material palette for all framing, detailing and areas of variation or highlight within inset infill zones, balconies, balustrades and openings across façades of the F1B Leisure Quarter - Residential portion of Plot F1 could include an expanded palette of metals, wood, terracotta, glazed brick/tile and ceramic elements, with associated pattern and texture/relief options for further interest.

6.10.12.12 - Warm and restrained natural tones of stone should be used, in particular local, or equivalent limestones, as well as the option for equivalent tone reconstituted stones and concretes. These should be used for the overall enclosure or 'frame' to the inset balconies and areas of infill.

6.10.12.13 - Material selection should be responsive to the neighbouring Castle Quay development.

6.10.12.14 - Promotion of the use of materials that incorporate recycled content and procuring products with a low environmental impact should be a priority when choosing materials. For further guidance see Chapter 6.9 of SWSH Visioning Framework Sustainability Statement.

6.10.12.15 - The secondary material palette should be complementary to the primary composition.

6.10.12.16 - Where the 'frame and infill' approach is used, material options for the infill zones of pigmented concretes, GRC and metals with associated patternation should be used.

6.10.12.17 - The tertiary material palette should be complementary to the primary composition.

6.10.12.18 - Warm and more exuberantly coloured and varied palettes of anodised, pre-oxidised and/or sealed/coated pre-weathered metals, terracotta and ceramics, acetylated woods and any associated patternation, texturing and detail can be used for specific areas of variation, highlight and any framing/detail work.

6.10.12.19 - All materials chosen should be hard wearing and must age well in a maritime environment.

6.10.12.20 - Colours for the window frames, door frames, fins, balcony metalwork and other architectural and design features must be complementary to the materials used on the rest of the building.

6. Plot Guide

6.10 Plot F1

6.10.12 Material Appearance

F1A - PRIMARY PALETTE



Figure 6.712 Pre-cast concretes



Figure 6.713 Re-constituted stones



Figure 6.714 Glazing/Transparencies

F1B - PRIMARY PALETTE



Figure 6.718 Limestones



Figure 6.719 Reconstituted stones



Figure 6.720 Concretes

F1A - SECONDARY PALETTE



Figure 6.716 Anodised, pre-oxidised and/or sealed/coated pre-weathered metals, ceramics/ terracotta and GRCs

F1A - TERTIARY PALETTE



Figure 6.717 Texture, relief, porosity and kinetic treatments

F1B - SECONDARY AND TERTIARY PALETTES

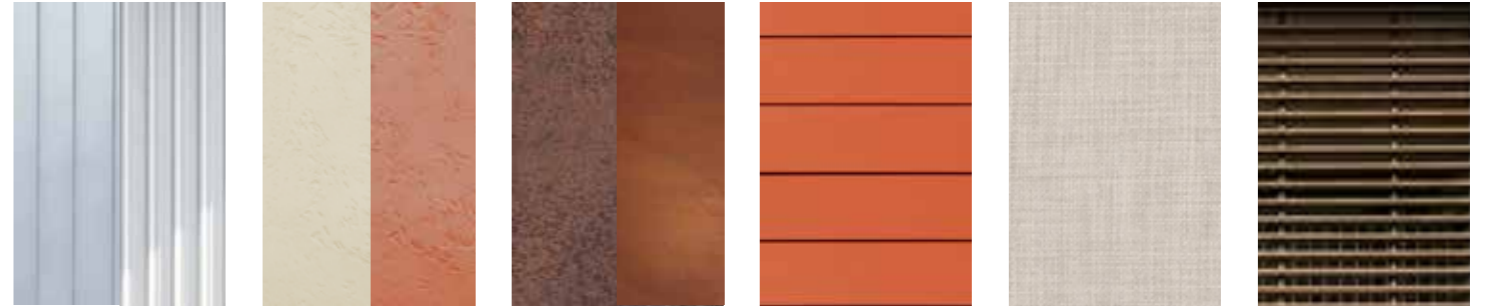

Figure 6.722 Pigmented concretes, GRCs and cementitious cladding types, anodised, pre-oxidised and/or sealed/coated pre-weathered metals, terracotta and ceramics, fabrics and hard wearing or acetylated wood

6. Plot Guide

6.11 Plot G1

6.11.1 Overview

Plot G1 occupies the tapering plot of land between the Esplanade and the Rue de la Libération at the northern edge of the Framework. Its prominent location, unique position relative to the intersection of streets and urban character and vertical block typology makes it a potential new gateway to the SWSH Visioning Framework development overall.

6.11.1.1 - The use for plot G1 should include food and beverage, arts and culture, and residential.

6.11.1.2 - Arts and culture, food and beverage and residential lobby uses should be used on ground floor. Food and beverage, and bar use should only be on the rooftop/top most floors.

6.11.1.3 - The maximum plot parameter diagrams identify the maximum extent permissible of the building. See figures 6.727 and 6.728.

6.11.1.4 - All building elements with the exception of projecting balconies must be designed within the maximum plot parameters.



Figure 6.725 Plot G1 parameters key plan

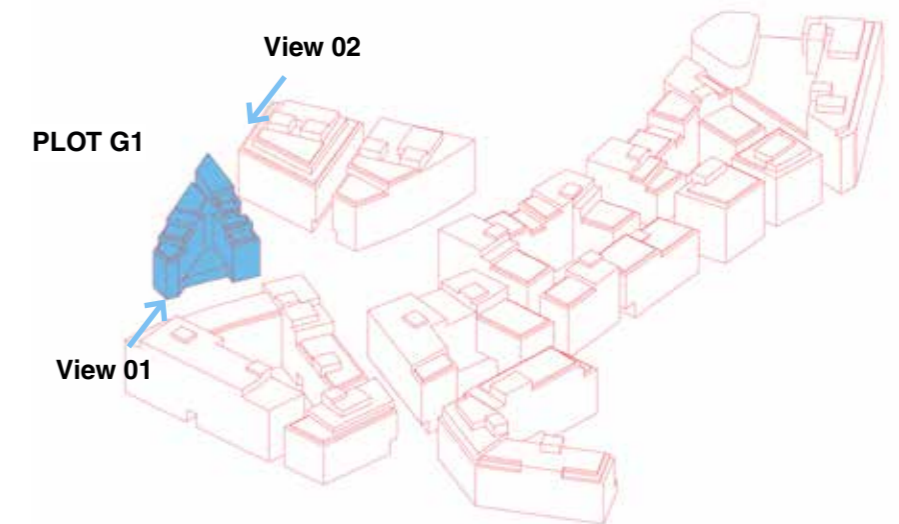

Figure 6.726 Plot G1 parameters key diagram

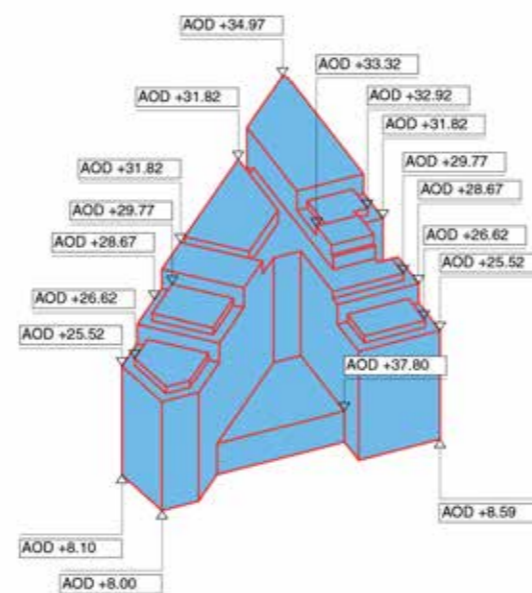

Figure 6.727 Plot G1 maximum plot parameters diagram - View 01

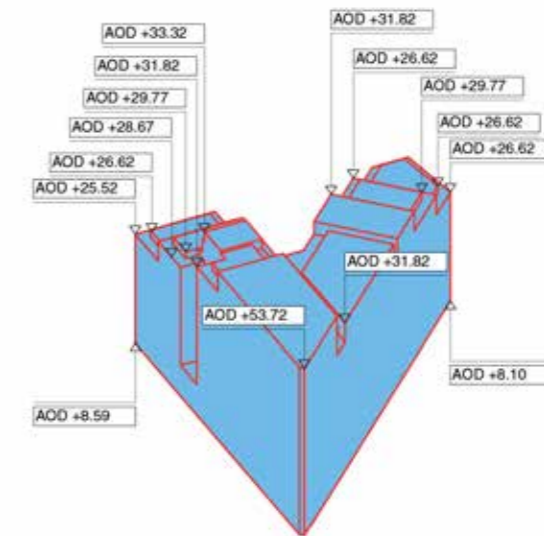

Figure 6.728 Plot G1 maximum plot parameters diagram - View 02

6. Plot Guide

6.11 Plot G1

6.11.2 Plot Overview

Figure 6.749 provides the key plot dimensions for Plot G1 and indicates its relationship to the illustrative landscape framework including the new Esplanade Square between plots G1 and G2.

For further details on dimensions of key routes and codes relating to Plot G1's relationship with the public realm please refer to Chapter 4 - Prescription of Future development - Public realm and Open Space, of this document.



Legend

- Plot G1
- Adjacent Plots

6. Plot Guide

6.11 Plot G1

6.11.3 General Appearance

The analysis in Chapter - 5.8 Approach to Architecture of the Design and Access Statement indicates the plot should respond in scale and façade articulation to the adjacent existing architecture of the Esplanade and the proposed typology areas.

Plot G1 is envisaged as a proud beacon signifying the development ambition and dynamic future of the St Helier and should be designed as a gateway building.

The architectural language of each façade should be consistent although the composition may vary to respond to specific site conditions e.g. views out and privacy as well as access to and mitigation from daylight/sunlight.

6.11.3.1 - The elevations should respond appropriately to their setting and their expression should complement the architectural language of adjacent plots and the building's prominent location within the Framework.

6.11.3.2 - The building envelope must define a clear bottom, middle and top through the architectural expression and treatment of the façades. See figure 6.751.

6.11.3.3 - Consideration must be given to how the building interfaces with the ground and the skyline with particular attention to the roof profile in order to create a varied roofline whilst respecting views to Fort Regent.

6.11.3.4 - There must be depth and layering in the articulation of the façades commensurate with a high quality residential building.

6.11.3.5 - The building envelope should be orientated to optimise views towards the sea front and articulated to reflect the dynamism of the plot's location within the Framework.

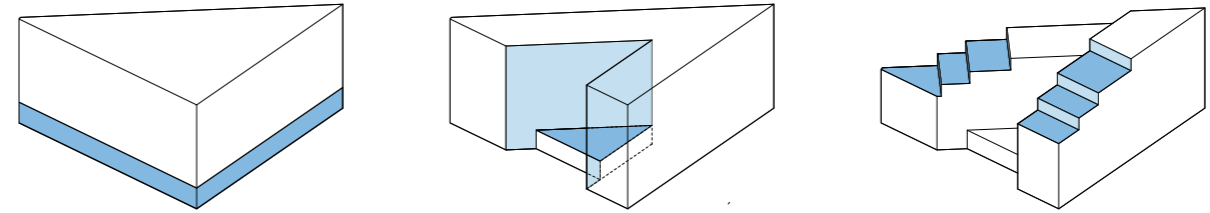

Figure 6.730 Plot G1 - An indicative articulation of G1 volume to promote views out, allow light in and follow the dynamism of the plot location

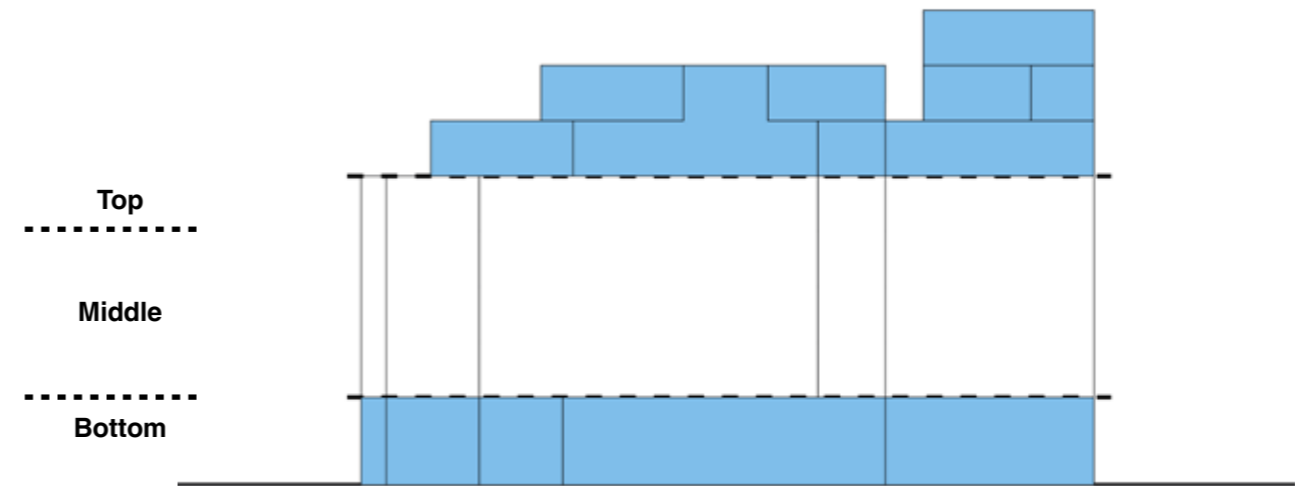

Figure 6.731 Plot G1 - The Apex building reference elevation with the top, middle and bottom clearly defined by ground and roof treatments

6. Plot Guide

6.11 Plot G1

6.11.4 Wind Mitigation

The impact of wind on the public and private realm environment should be mitigated by the incorporation of design features highlighted in the SWSH Visioning Framework Wind and Microclimate Assessment.

6.11.4.1 - Rooftop balustrades and set backs must be used as indicated in 6.11.6 G1 - Top of the Building.

6.11.4.2 - Canopies should be used if a set back is not provided for wind mitigation.

6.11.4.3 - Wind mitigation solutions should be complementary to overall architectural typology and integrated into the building design.

6.11.4.4 - Inset balconies must be considered as a wind mitigation device as indicated in section 6.11.11 Balconies. See figure 6.734.

6.11.4.5 - The design of plot G1 must incorporate wind mitigation measures as identified in the wind chapter of the EIS, or alternative equivalent measures to achieve the same mitigation effect developed and tested through detailed design.

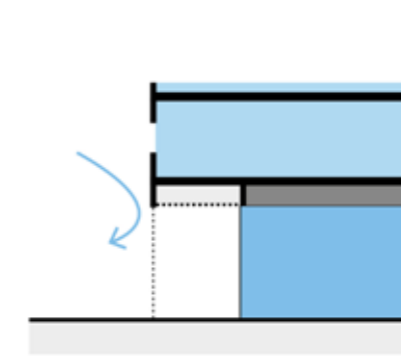

Figure 6.733 Set backs for wind mitigation

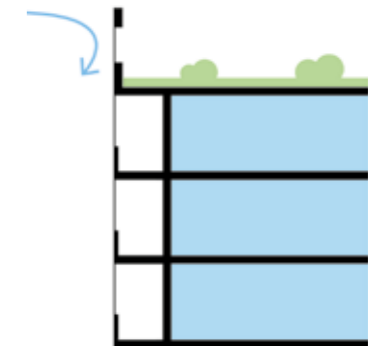

Figure 6.734 Façade upstand for wind mitigation



Figure 6.735 Example of set back sheltered space



Figure 6.736 Example of façade upstand

6. Plot Guide

6.11 Plot G1

6.11.5 Massing

A maximum AOD has been established for Plot G1. The maximum AOD is higher than the surrounding context so that the plot forms a vertical block type.

6.11.5.1 - The ground floor of Plot G1 should be a minimum of 5m floor to floor. This will maximise the ground level for retail, culture and arts uses and allow for the incorporation of a mezzanine level. See figure 6.737.

6.11.5.2 - The typical floor to floor setting out for above ground floor level should allow for residential use. See figure 6.737.

6.11.5.3 - The floor to floor setting out at the top of the plot should allow for food and beverage and/or bar and entertainment use.

6.11.5.4 - Figure 6.738 identifies the maximum and minimum shoulder heights permissible.

6.11.5.5 - The maximum number of storeys permissible for Plot G1 should be 12 storeys (Ground plus 11).

6.11.5.6 - The minimum recommended number of storeys for Plot G1 should be 5 (Ground plus 4).

6.11.5.7 - Balustrades and privacy screens may project above the shoulder height provided they are contained within the accessible terrace zone as indicated in figure 6.739.

Legend

- Maximum plot parameters
- +5m Floor to floor base zone
- Indicative shaped massing where applicable
- Suggested roof treatment & accessible terrace zones

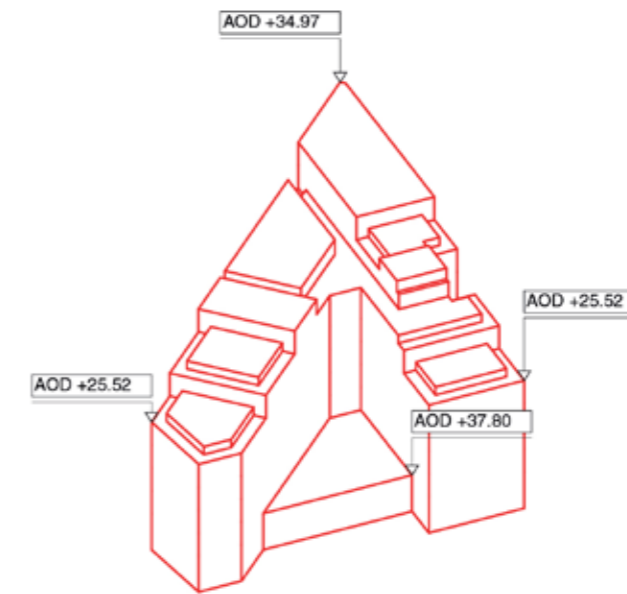

Figure 6.738 Plot G1 Minimum and maximum plot parameters

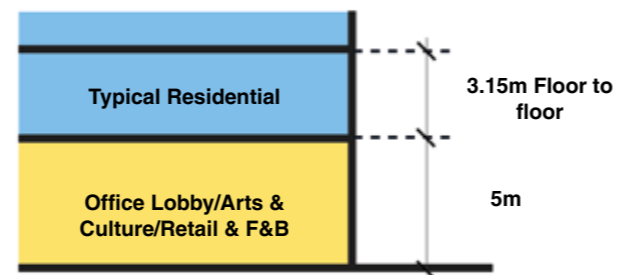

Figure 6.737 Typical floor to floor

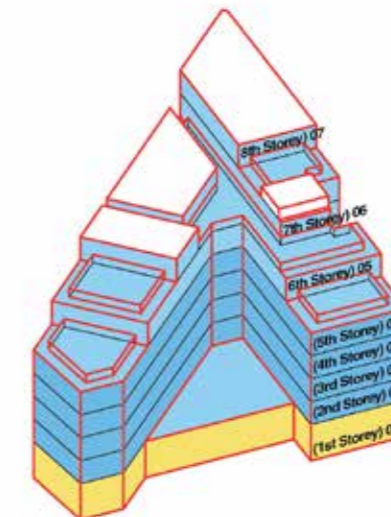

Figure 6.739 Plot G1 Indicative allowable massing set up within maximum plot parameters

6. Plot Guide

6.11 Plot G1

6.11.6 Top of the Building

G1 TOP OF THE BUILDING - ROOF PROFILES

General approach to G1 is to have roof terrace amenity space set back from the roof edge to reduce the perceived building height.

6.11.6.1 - Upstand, setback and flat roof elements must be incorporated to allow for sheltered greenspaces and terraces.

6.11.6.2 - Accessible terrace zones must be provided and should be set back from the façade by a maximum of 1.5m and have an upstand of maximum 1.1m. See figure 6.742.

6.11.6.3 - Perimeter and setback upstands for shelter and guarding should be provided to all accessible roofs.



Figure 6.740 Plot G1 Rooftop setback plan

Legend

- Maximum plot parameters
- Indicative suggested massing
- Accessible flat roof terrace
- Non-accessible roof
- Indicatively placed Technical/Plant Zones
- Indicative Core Positions

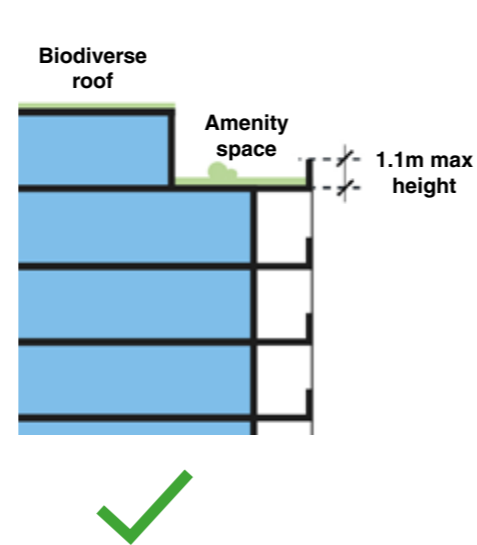

Figure 6.741 Upstand to 1.1m min

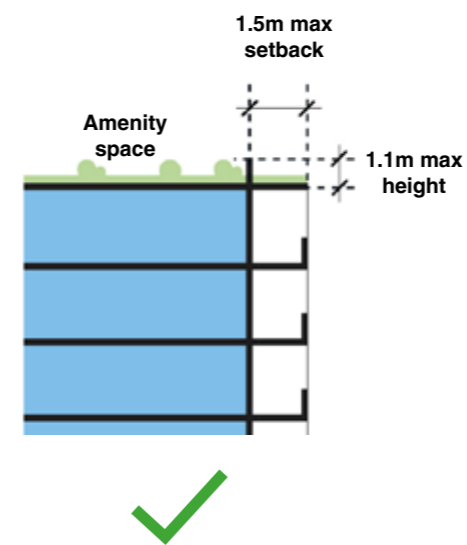

Figure 6.742 Upstand to 1.1m min and a 1.5m min setback

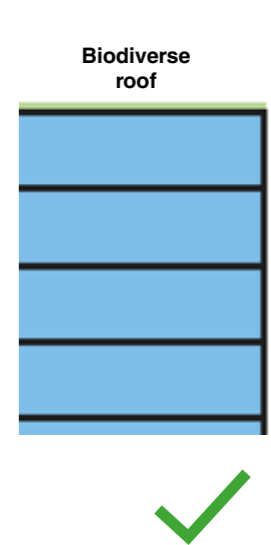

Figure 6.743 Flat biodiverse roof to building edge

6. Plot Guide

6.11 Plot G1

6.11.6 Top of the Building

G1 TOP OF THE BUILDING - ROOF TECHNICAL ZONE

A maximum AOD has been established for Plot G1. This includes a 3m high technical zone set back from the roof edge to accommodate roof plant and the building core.

Where not designated for accessible roof zones, a technical/plant zone exists that encompasses the maximum extents for any final arrangements of required plant.

All core positions, both full storey lobbied roof access extensions or nominal overruns, are shown indicatively.

6.11.6.4 - Any plant is to be located wherever possible within a technical zone set back 3m from the façade line with a maximum 3m high enclosure.

6.11.6.5 - Green or brown roofs should be provided to all non accessible roof areas.

6.11.6.6 - Where rooftop plant cannot be set back and occurs close to the roof edge it should be screened by the extension of the façade.

6.11.6.7 - All core positions, both full storey lobbied access extensions or nominal overruns should be located within the technical zones.

Legend

- Maximum Plot Parameters
- Indicative Suggested Massing
- Set back zone for Technical/Plant areas (no plant in these areas)
- Maximum Extents available for potential Technical/Plant Zone
- Indicatively placed Technical/Plant Zones
- Indicative Core Positions

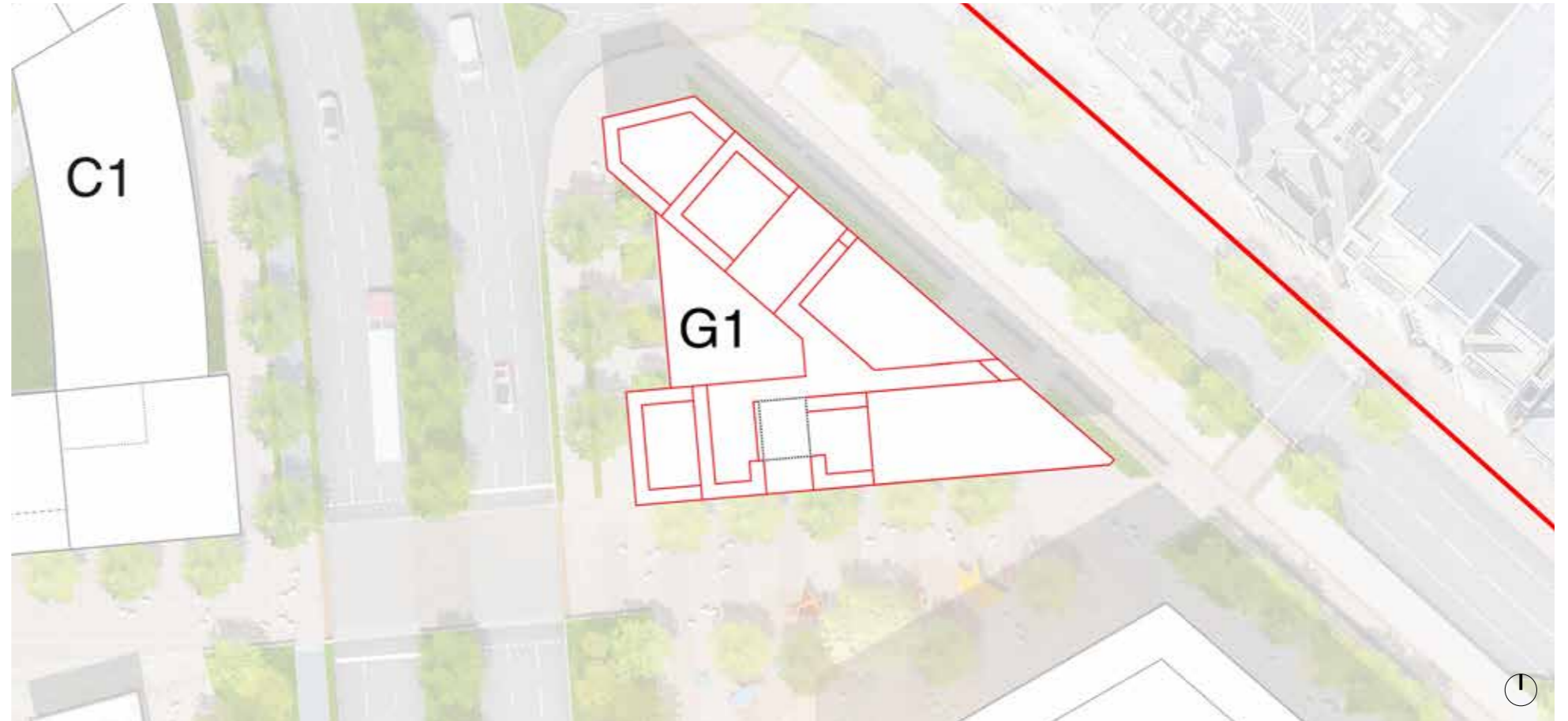

Figure 6.744 Plot G1 Maximum extents and setback roof plan

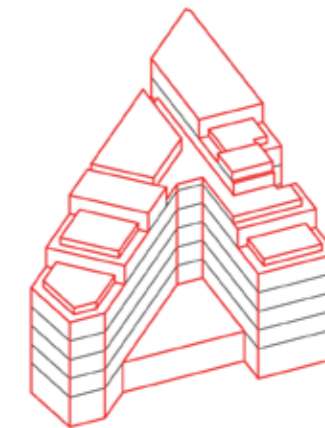

Figure 6.745 Plot G1 Available technical zones within maximum plot parameters

6. Plot Guide

6.11 Plot G1

6.11.7 Middle of the Building

The overall approach is to create an elegant, high-quality building. The façades should provide a strong frontage, contributing to the identity of the development. The urban analysis (DAS - 5.8 Approach to Architecture) and the plot's location suggests that the middle of the building should be designed to maximise views towards the sea and its massing articulated to emphasise its verticality.

The architectural language of each façade should be consistent and a regular sub-grid should be created to provide a hierarchy and ordering principle for the glazing and balconies. Balconies are to be integrated into the overall faced composition and set back to provide sheltered external amenity space.

The plot location and its 360-degree orientation will require appropriate façade approaches and passive solar control techniques depending on the final façade orientation.

6.11.7.1 - The elevations should respond appropriately to their setting and their expression should follow the architectural language of the Apex typology.

6.11.7.2 - There must be depth and layering including expression of building structure within the articulation of the façades to provide a sense of quality.

6.11.7.3 - Designers should follow the glazing percentage per façade as set out in the Chapter 5.17 Windows.

6.11.7.4 - Windows and glazing should maximise opportunities for views towards the sea front whilst allowing for privacy between residential units.

6.11.7.5 - Unrelieved stacks of glazing should not be used, instead expressed structure and articulated cladding bays with considered integration of shading devices; louvres/ bris soliels and solid cladding should be used. See figure 6.747.



Figure 6.746 Example of Framed Elevation and Lightweight Structure



Figure 6.747 Acceptable high quality façade avoiding unrelieved stacks of glazing with integrated shading elements.

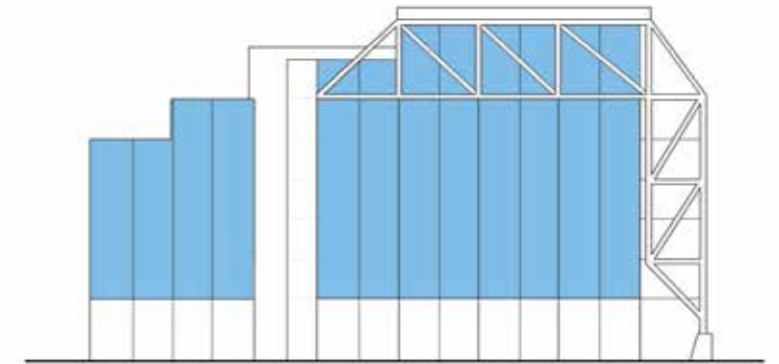

Figure 6.748 Plot G1 Elevation - with vertical subdivision of mass indicated

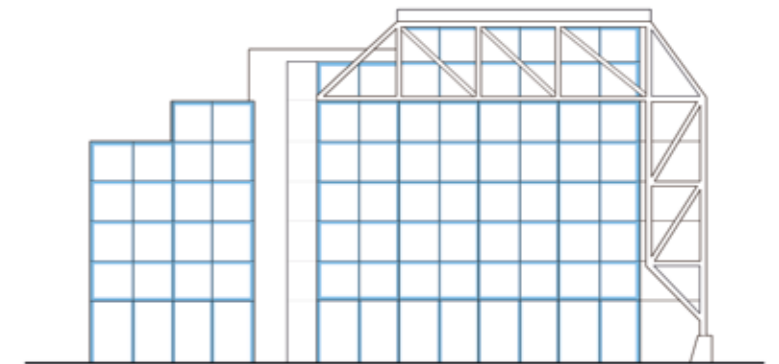

Figure 6.749 Plot G1 Elevation - with banding of bays within the vertical indicated

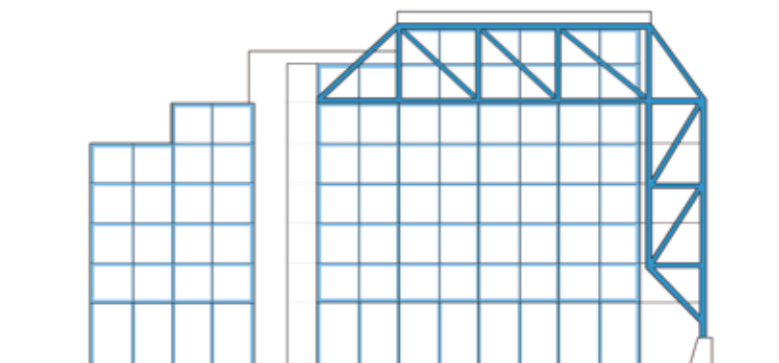

Figure 6.750 Plot G1 Elevation - with a structural bracing expression indicated

6. Plot Guide

6.11 Plot G1

6.11.8 Bottom of the Building

There may be a number of entrances required on this building including one for the residential atrium/lobby and at minimum one for the cultural use. Secondary entrances include any fire escape and/or service/loading entrance(s) that may be required.

All entrances should be carefully integrated into the façade and should be coherent with the façade material expression.

The plot is on a gradient. The location of the entrances at ground floor level should take into account any variance in external levels.

6.11.8.1 - A minimum of one residential entrance and associated lobby must be provided.

6.11.8.2 - A minimum of one cultural and arts entrance, and any associated lobby/separate entrance for roof top food and beverage uses must be provided.

6.11.8.3 - Entrances must be clearly legible through articulation and design and must have a high quality appearance.

6.11.8.4 - All entrances must be carefully integrated into the massing of the building.

6.11.8.5 - Ground floor residential is not permitted in Plot G1.

6.11.8.6 - Additional height at ground level should allow for a mezzanine and the option for direct mezzanine access via an escalator. See figures 6.752 and 6.754.

Legend

- Zone for art and community entrances
- Zone for residential entrances
- Zone for non residential / service entrances

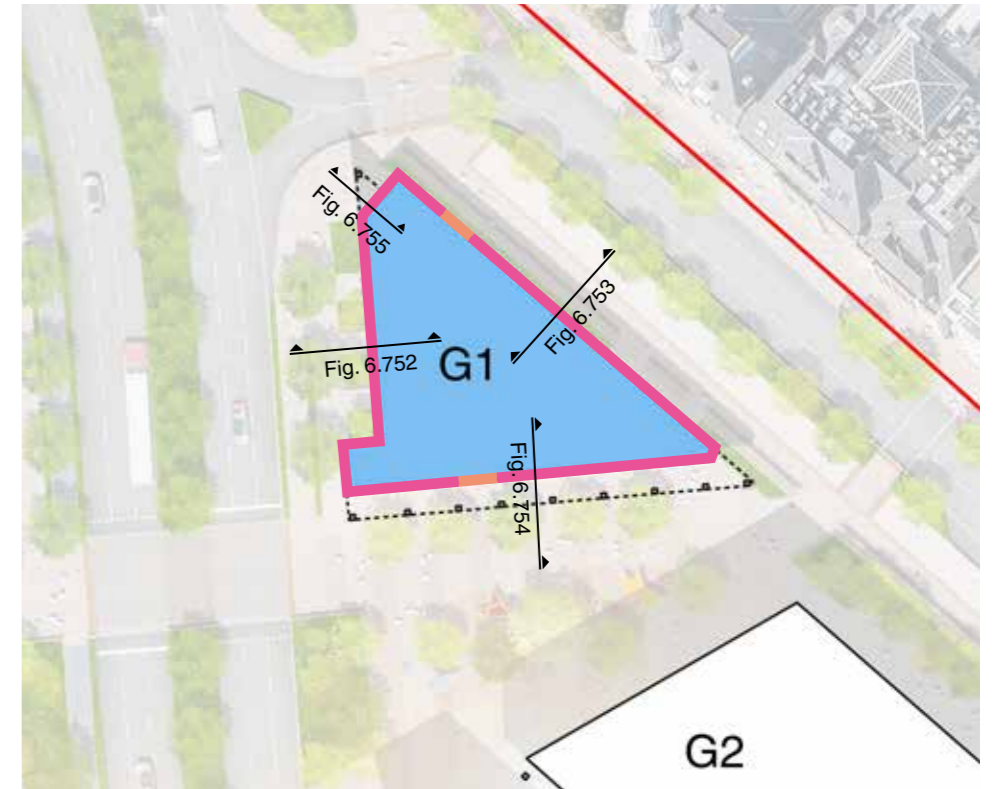

Figure 6.751 Plot G1 bottom of building suggested condition

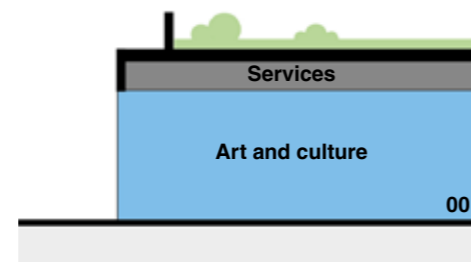

Figure 6.752 Section through podium garden

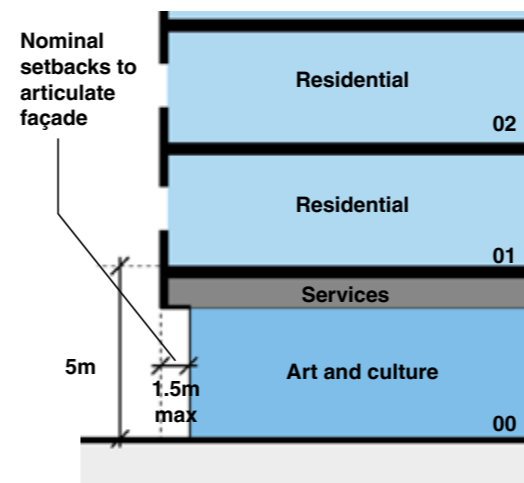

Figure 6.753 Nominal setback condition

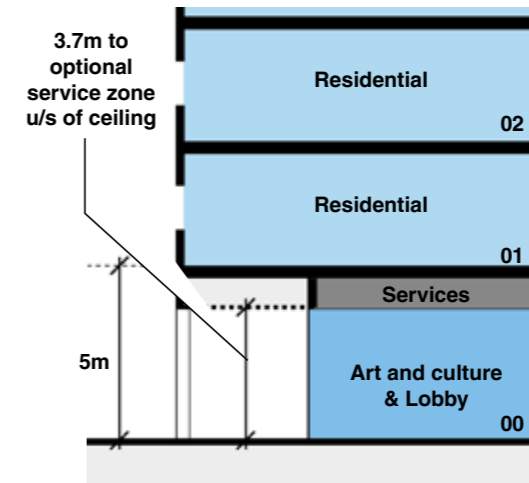

Figure 6.754 Colonnade at ground floor condition

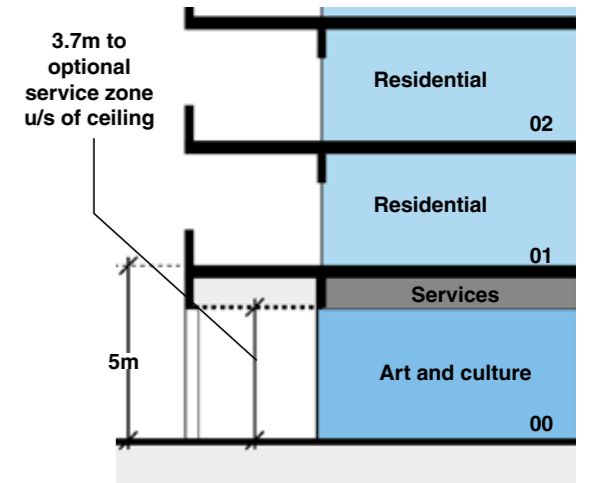

Figure 6.755 Colonnade at ground floor condition

6. Plot Guide

6.11 Plot G1

6.11.8 Bottom of Building

Frontages should be complimentary to the building and provide visual interest at ground level. The bottom of the building has a 360 frontage and forms part of the streetscape and highway experience when moving through the development.

6.11.8.7 - Plot G1 shall provide ground level cultural uses (see Chapter - 4.1.3 Use Distribution) and a separate residential entrance lobby.

6.11.8.8 - The bottom of the building must have a strong architectural expression and create an active frontage to the Esplanade Square. It must not be an unrelieved tower base with no other uses (see Chapter - 5.16 Bottom of building).

6.11.8.9 - The frontage to the cultural and arts use should be complimentary with the overall material palette of the building. The bottom of the building allows for a number of different configurations and these should be allowed for within the design. See figures 6.759, 6.760 and 6.761.

6.11.8.10 - Residential lobbies should be set in from street line with mainly glazed frontages. Where required, residential entrance lobbies should have either integrated revolving doors or wind lobbies.

6.11.8.11 - The ground level of Plot G1 should have a distinctive design within the Framework. Designers should consider how the additional height can provide dynamic expression to the bottom of the building given its prominent location.

Legend

- Suggested zone for art / cultural entrances and lobbies
- Automatic doors
- Suggested potential art gallery
- Suggested zone for multi-use cultural space
- Residential above - datum varies above the arts/cultural spaces



Figure 6.756 Example of blend of indoor and outdoor public space at bottom of building



Figure 6.757 Example of potential mezzanine to community space



Figure 6.758 Example of a flexible event/cultural multi-use space

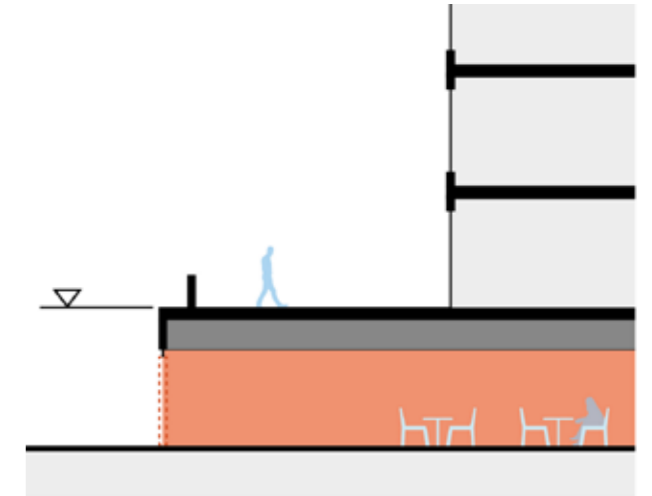

Figure 6.759 Illustrative entrances at ground

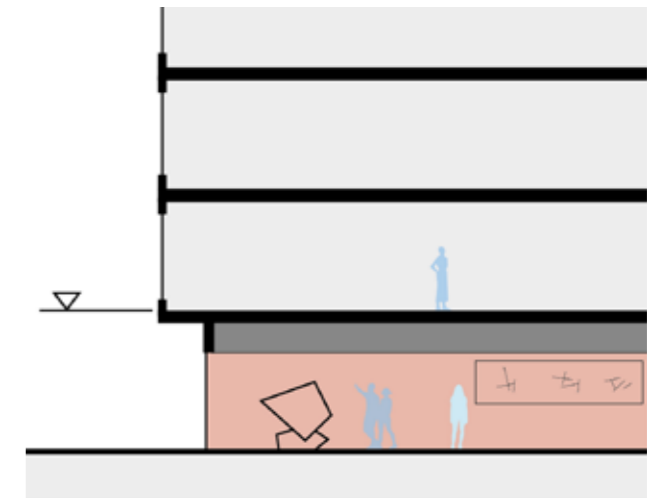

Figure 6.760 Illustrative art gallery space

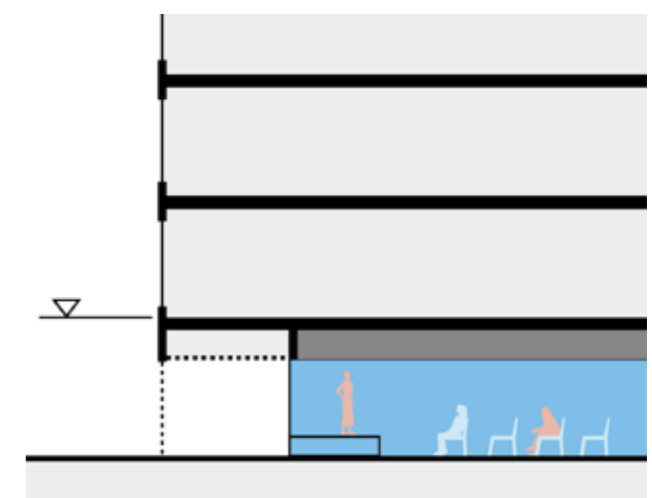

Figure 6.761 Illustrative flexible cultural space

6. Plot Guide

6.11 Plot G1

6.11.9 Adjacent Buildings

Plot G1 is located within close proximity to plot G2.

6.11.9.1 - Consideration for balcony placement and openings should be taken to minimise proximity issues where façades face onto adjacent plots such as C1, G2 and G3, see also section 6.11.10 and 6.11.11.

6.11.9.2 - Consideration of the roof terrace and commercial food and beverage layouts should be taken to minimise issues between adjacent buildings.

6.11.9.3 - Consideration of window placement and directional framing should be taken where plots are directly adjacent to one another to minimise overlooking, see chapter 5.18 Proximity and Overlooking for further guidance.



Figure 6.762 Plot G1 Building adjacencies key plan

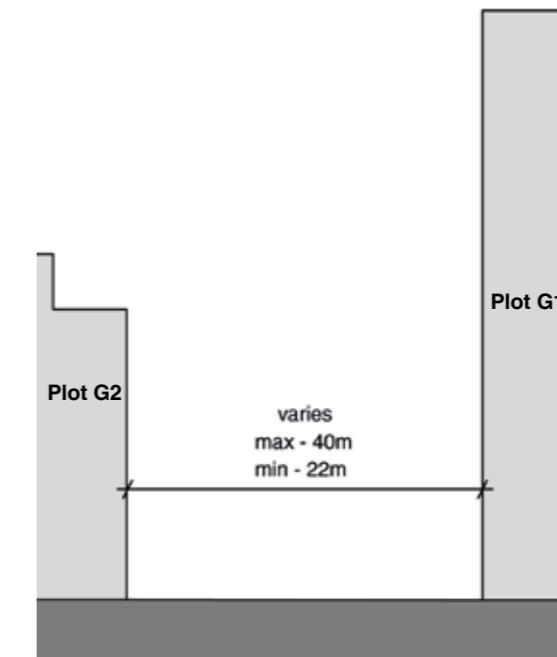

Figure 6.763 Building adjacency between G1 and G2

6. Plot Guide

6.11 Plot G1

6.11.10 Openings

G1 OPENINGS IN THE FAÇADE

Designers should pay careful attention to the placement of openings across the façade. Whilst different opening compositions should be considered, they should also be part of a coherent façade openings strategy.

6.11.10.1 - Windows should form consistent patterns across the façade or within repeat bays.

6.11.10.2 - Window and balconies must be integrated within the façade systems in a clean and cohesive manner. See figure 6.764.

6.11.10.3 - All façades are to have a considered level of detail to the window openings, including depth, reveals and framing. This is to give a high quality layered result.

6.11.10.4 - Areas for building services should be treated as screened openings with colour and materiality coordinated with the façade materials (e.g. louvres/ventilation grills), for a coherent elevation strategy. These should be minimised on principal elevations wherever possible.

6.11.10.5 - Consideration for access for the cleaning, maintenance and potential replacement of window elements should be given when designing openings.

6.11.10.6 - Where building envelope has been orientated to optimise views towards the sea front designers should maximise the opportunity to provide framed views with inset balconies and large window openings. See figure 6.765.

6.11.10.7 - Where building envelope has been articulated to introduce daylight and ventilation between residential units, operable windows should be considered. See figure 6.766.

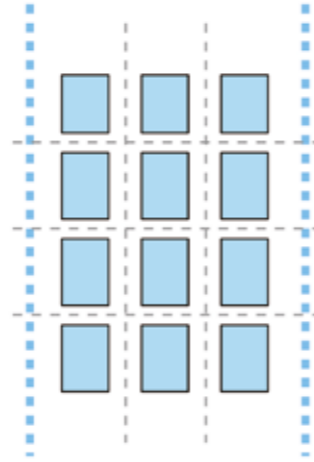

Figure 6.764 Gridded window layout

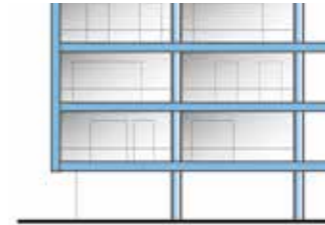

Figure 6.765 Inset balconies and structure to a regular grid

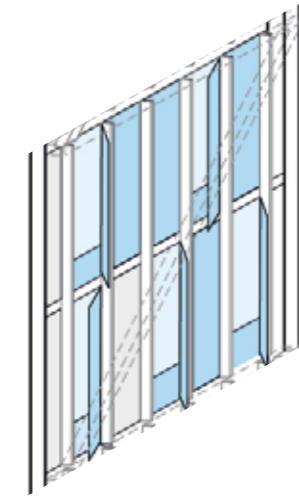

Figure 6.766 Variation in window detail

6. Plot Guide

6.11 Plot G1

6.11.11 Balconies

G1 BALCONY CONDITIONS

The balcony arrangement should be carefully positioned as part of the overall composition of the façade.

Consideration of the balcony location should be taken into account in order to avoid overlooking and proximity issues.

The predominant balcony design should be inset and integrated to the overall design taking into account views available.

6.11.11.1 - Inset balconies should be used. Proud balconies and Juliet balconies should not be used.

6.11.11.2 - Balustrades must be complementary to the façade design.

6.11.11.3 - A minimum balustrade height of 1.1m must be provided for all balconies.

6.11.11.4 - Horizontally barred balustrades are not permitted as they are a climbing hazard.



Figure 6.767 Plot G1 balcony condition key plan

Legend

- Building boundary
- Inset, juliet and proud balconies

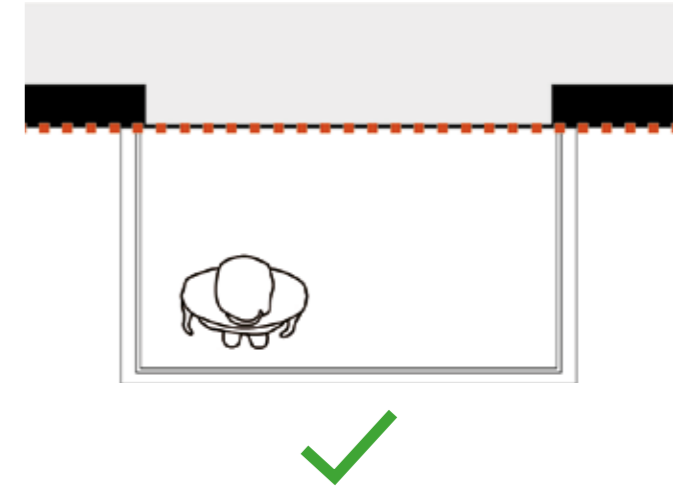

Figure 6.768 Proud balcony condition

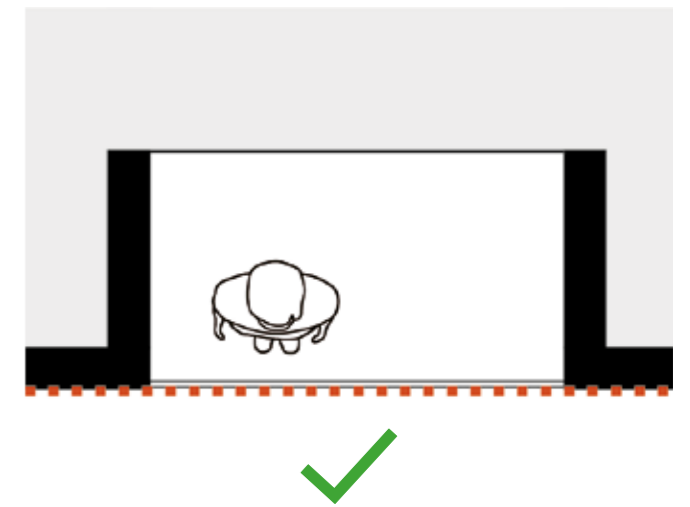

Figure 6.769 Inset balcony condition

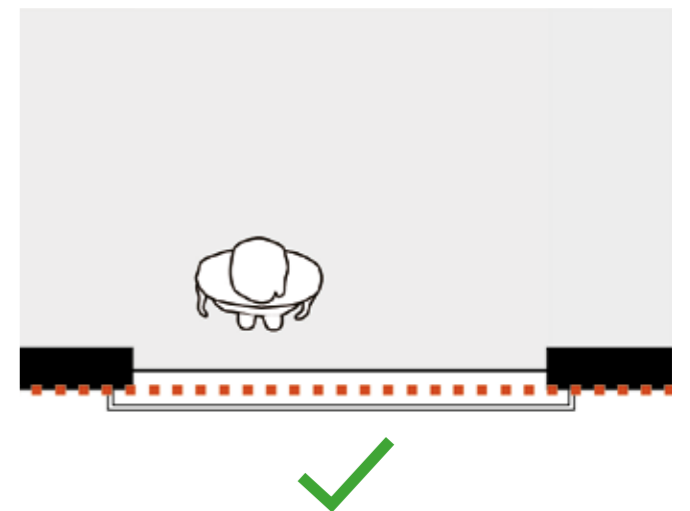

Figure 6.770 Juliet balcony condition

6. Plot Guide

6.11 Plot G1

6.11.12 Material Appearance

Hard-wearing and long-life quality materials should be selected. This should take inspiration from the existing local façade colours, textures and materials and new or complementary material types can be introduced where appropriate.

Care should be taken when sourcing all materials to ensure minimum environmental impact and the sustainable credentials of the source and the materials lifecycle, see Chapter 6.9 of SWSH Visioning Framework Sustainability Statement for further guidance.

The primary material palette for Plot G1 should be drawn from both the St Helier local stone types in conjunction with a mix of re-constituted stone, concrete/GRC and glazing.

The secondary material palette should include any external shading devices including but not limited to bris soleil and louvres as well as any solid infill zones as required.

The tertiary material palette should be utilised for all framing, detailing and areas of variation or highlight within inset infill zones.

6.11.12.1 - Warm and restrained natural tones of stone should be used in particular local granites and limestones or equivalent reconstituted stones and concretes for areas of expressed structural framing.

6.11.12.2 - Material selection should be responsive to the neighbouring plots including the G2 + G3 Commercial Quarter typology and the International Financial Centre.

6.11.12.3 - Promotion of the use of materials that incorporate recycled content and procuring products with a low environmental impact should be a priority when choosing materials. For further guidance see Chapter 6.9 of Waterman's Sustainability Statement for Planning.

6.11.12.4 - The secondary material palette should be complementary to the primary composition.

6.11.12.5 - Where the infill zones within the main expressed frame, material options should include pigmented concretes, GRC and high quality pre-finished metals.

6.11.12.6 - The tertiary material palette should be complementary to the primary composition.

6.11.12.7 - Warm and more exuberant and varied materials should be used for the tertiary palettes to add patternation, texturing and detail.

6.11.12.8 - All materials chosen to be hard wearing and must age well in a maritime environment.

6.11.12.9 - Colours for the window frames, door frames, balcony metalwork and other architectural and design features must be complementary to the materials used on the rest of the building.

6.11.12.10 - Plot G1 should be designed as a distinctive building within the Framework. Designers should consider an innovative approach to the use of materials and building systems to make it an exemplar building for St Helier.

6.11.12.11 - Highly reflective or 'mirror like' glazing must not be used on any façade.

PRIMARY PALETTE



Figure 6.771 Limestones and Granites



Figure 6.772 Re-constituted Stone



Figure 6.773 Concretes



Figure 6.774 Concrete (recycled and glass)

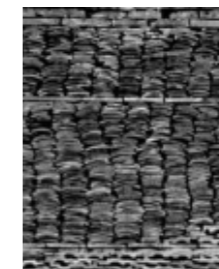

Figure 6.775 Salvage panels

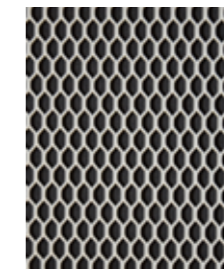

Figure 6.776 Jersey knit inspired metalwork



Figure 6.777 Oyster shell stucco



Figure 6.778 Concrete frame and painted steelwork



SECONDARY AND TERTIARY PALETTES

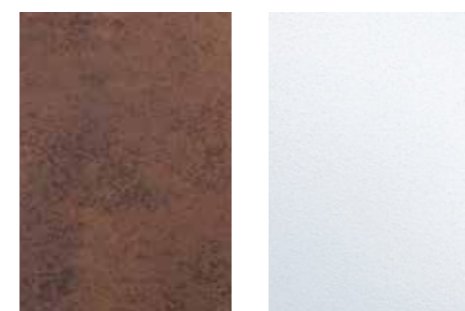

Figure 6.779 Weathered and pre-oxidised metals

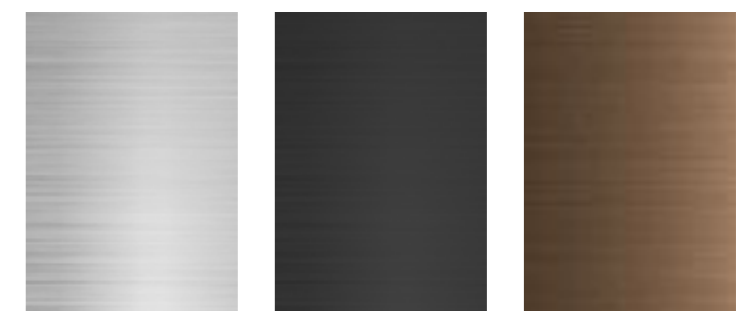

Figure 6.780 Various tones of anodised/ coated metals for detailing and highlights

This Page is Left Intentionally Blank

6. Plot Guide

6.12 Plot G2

6.12.1 Overview

Plot G2 is located in the eastern part of the site and forms one part of the two island plots adjacent to St Heliers International Financial Centre (IFC) developments and will be the latest evolution of the IFC as part of the Framework's Commercial Quarter.

The plot is part of the Commercial Quarter Typology as described in Chapter 5.9 - Architectural Typologies. The office block type has developed in response to the towns need for large floorplan, modern workplace environments capable of attracting international occupiers.

The plots also anchor and activate the southern edge of the proposed new Esplanade Square.

6.12.1.1 - The uses for plot G2 should include food and beverage, retail, arts and culture and office.

6.12.1.2 - Retail, food and beverage, cultural and office lobbies must only be used at ground floor. All floors above must be office use.

6.12.1.3 - The maximum plot parameter diagrams identify the maximum extent permissible of the building and should be read with the parameter plans. See figures 6.784 and 6.785.

6.12.1.4 - All building elements must be within maximum plot extent, with the exception of projecting balconies, canopies and awnings.



Figure 6.782 Plot G2 parameters key plan

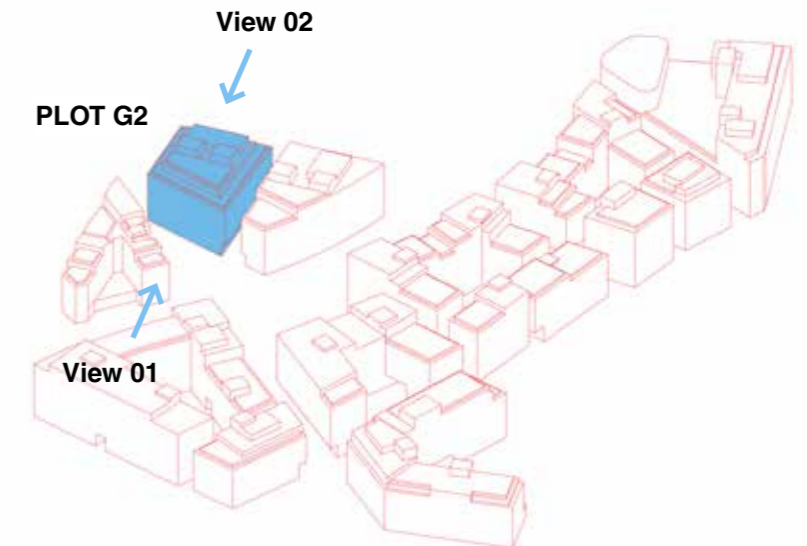

Figure 6.783 Plot G2 parameters key diagram

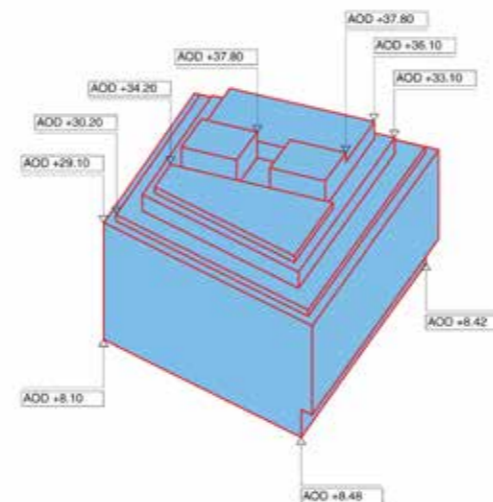

Figure 6.784 Plot G2 maximum plot parameters diagram - View 01

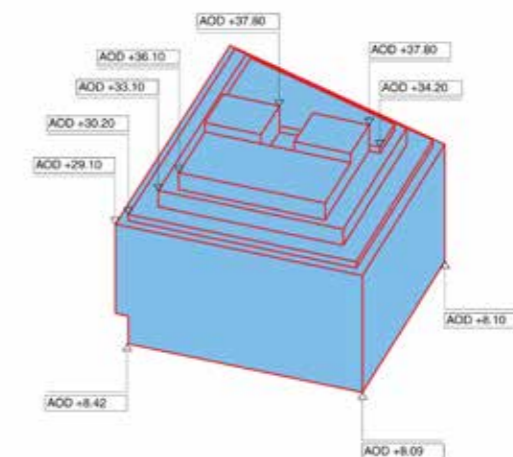

Figure 6.785 Plot G1 maximum plot parameters diagram - View 02

6. Plot Guide

6.12 Plot G2

6.12.2 Plot Overview

Figure 6.800 provides the key plot dimensions for Plot G2 and indicates its relationship to the illustrative landscape framework including the eastern end of the new Esplanade Square between plots G1 and G3.

For further details on dimensions of key routes and codes relating to Plot G2's relationship with the public realm please refer to Chapter 4 - Prescription of future development - Public realm and Open space, of this document set.

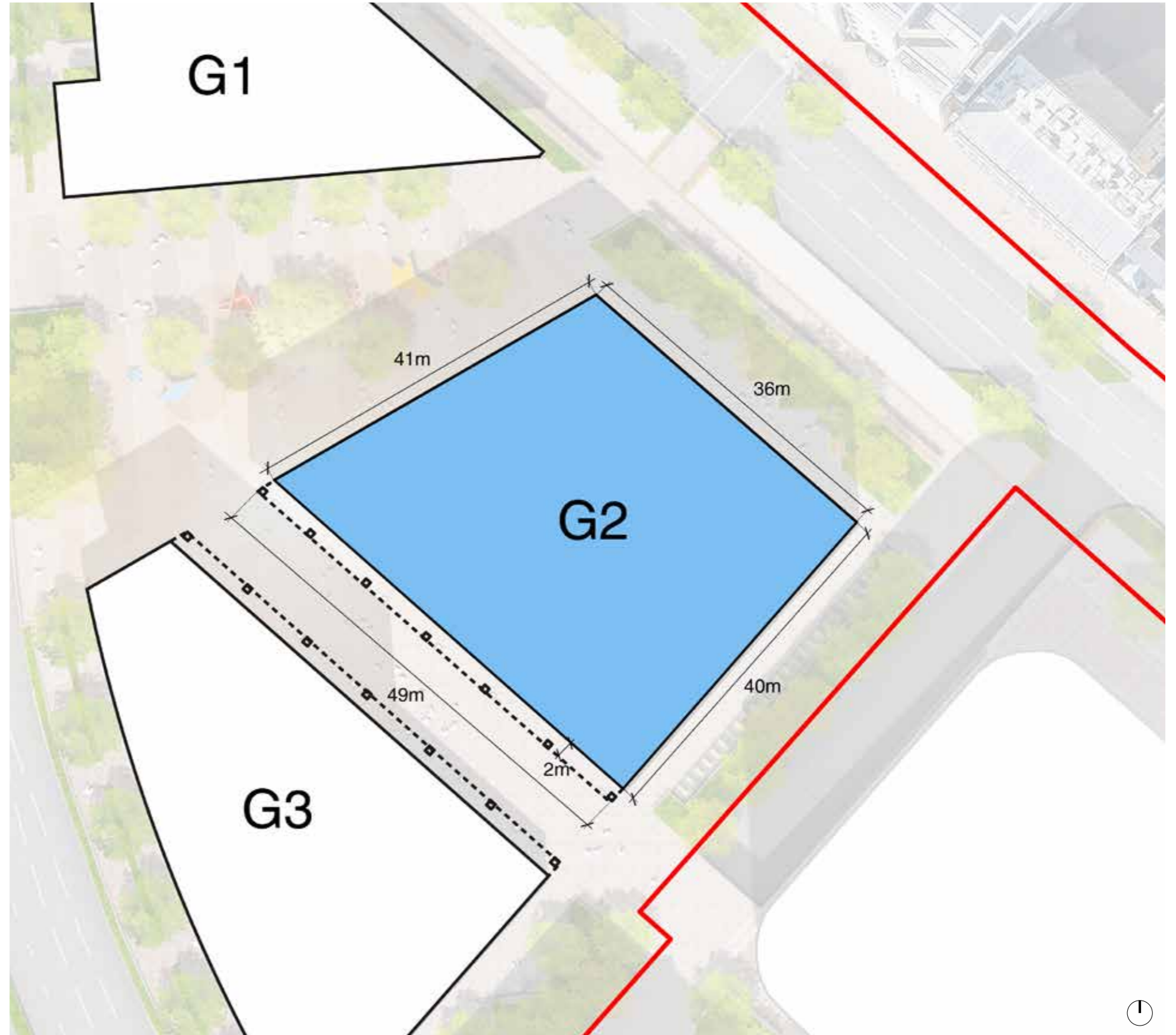



Figure 6.786 Plot parameter plan

Legend

-  Plot G2
-  Adjacent Plots

6. Plot Guide

6.12 Plot G2

6.12.3 General Appearance

The analysis in Chapter - 5.8 Approach to Architecture of the Design and Access statement indicates that the plot should respond in scale and architectural approach to the adjacent existing architecture of the IFC and some of the new contemporary commercial developments along the Esplanade.

Although a continuum of the existing IFC development in scale and reflecting the high quality, contemporary architecture of the IFC, it needs to potentially attract the next generation of occupiers keen to visibly project their socially and environmentally responsible credentials.

The overall approach is to create an impression of a campus of buildings. The façades should provide an active frontage at ground, contributing to the identity of the development.

The architectural language of the façade should be consistent on all four sides of the island plot although the composition may vary to respond to specific site considerations e.g. façade orientation or the provision of colonnades.

6.12.3.1 - The elevations should respond appropriately to their setting and their expression should complement the architectural language of plots G3 and G1.

6.12.3.2 - Plot G2 forms part of the Commercial Quarter typology and should respect the Apex building and the existing IFC buildings opposite.

6.12.3.3 - The building envelope must define a clear base, middle and top through the architectural expression and treatment of the façade. See figure 6.801.

6.12.3.4 - Consideration must be given to how the building interfaces with the ground and the skyline with particular attention to the roofscape including terraces and plant areas in order to minimise vertical impact of these large plots.

6.12.3.5 - There must be depth and layering in the articulation of the façades to provide a sense of quality in particular at ground level where the bottom of building forms a key edge to the Esplanade Square.

6.12.3.6 - Variations in depth, height and materials should be used to break down the horizontal elevation into distinct vertical proportions. See figure 6.804 in 6.12.7 Middle of Building.

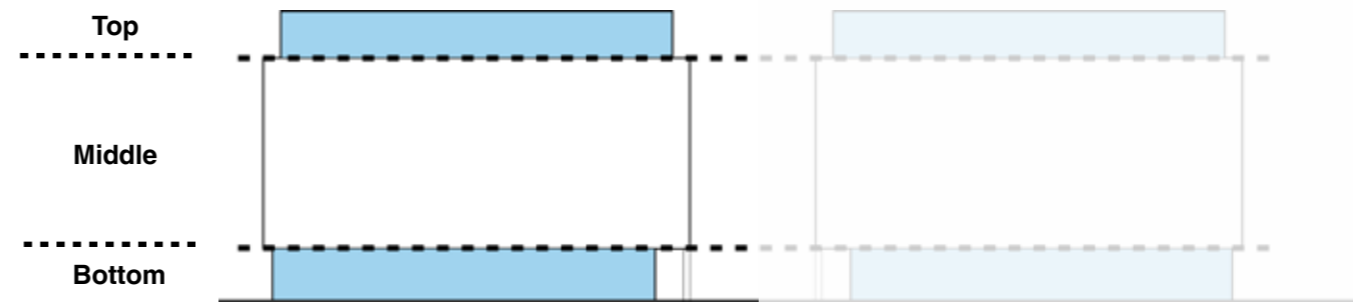

Figure 6.787 Plot G2 - The Esplanade Square reference elevation of G2 (with adjacent G3) Top, Middle and Bottom clearly defined by ground and roof treatments

6. Plot Guide

6.12 Plot G2

6.12.4 Wind Mitigation

The impact of wind on the public and private realm environment should be mitigated by the incorporation of design features highlighted in the SWSH Visioning Framework Wind and Microclimate Assessment.

6.12.4.1 - Rooftop balustrades and set backs must be used to G2 terraces as indicated in section 6.10.6 - Top of the Building.

6.12.4.2 - Colonnades must be introduced where indicated in plans as indicated in figure 6.803 opposite.

6.12.4.3 - Canopies/awnings should be considered where there are no colonnades. See figure 6.804.

6.12.4.4 - Wind mitigation solutions should be complementary to overall architectural typology and integrated into the building design.

6.12.4.5 - The design of plot G2 must incorporate wind mitigation measures as identified in the wind chapter of the EIS, or alternative equivalent measures to achieve the same mitigation effect developed and tested through detailed design.

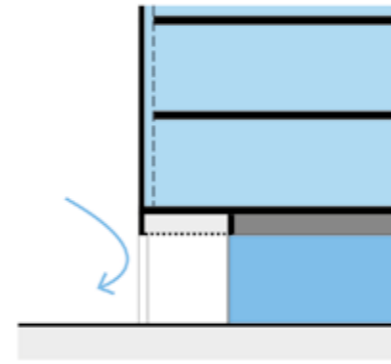

Figure 6.789 Colonnades for wind mitigation

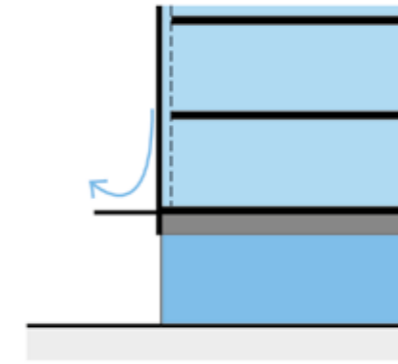

Figure 6.790 Canopy and awning wind for mitigation

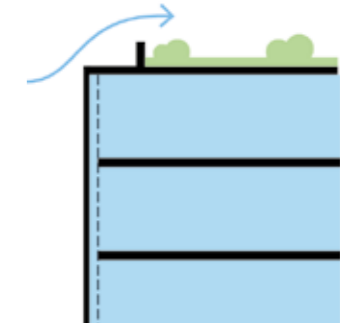

Figure 6.791 Setback upstand for wind mitigation



Figure 6.792 Example of a colonnade



Figure 6.793 Example of awnings

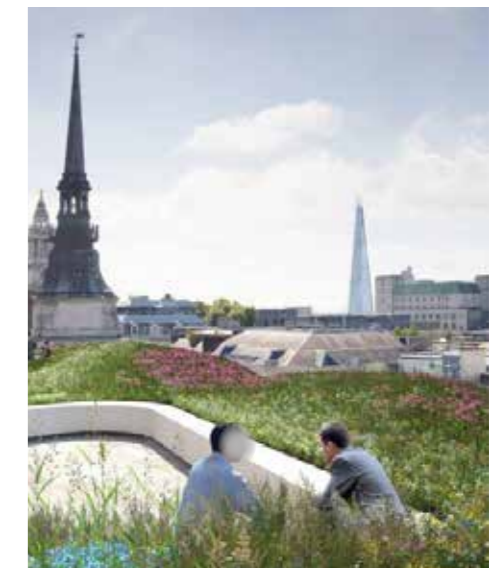

Figure 6.794 Example of 1.1m upstand with planting behind

6. Plot Guide

6.12 Plot G2

6.12.5 Massing

A maximum AOD has been established for Plot G2. It is an island plot and has defined maximum shoulder heights that are consistent on all four elevations. Within these maximum extents the application of architectural treatments such as set backs, terraces and plant screens should be used to help reduce the perceived building height from ground as well as add variation to the roof line.

6.12.5.1 - The ground floor of Plot G1 should be a minimum of 5m floor to floor to maximise the ground level for retail and cultural uses and to activate the frontage onto the Esplanade Square. See figure 6.795 for further guidance.

6.12.5.2 - The maximum number of storeys permissible for plot G2 is 8 storeys (Ground plus 7).

6.12.5.3 - Figure 6.810 identifies the maximum shoulder heights permissible.

6.12.5.4 - The roof top technical zone for Plot G2 has a consistent set back to reduce its vertical impact upon the street below.

- Legend**
- Maximum plot parameters
 - +5m Floor to Floor base zone
 - Indicative shaped massing where applicable
 - Suggested roof treatment & accessible terrace zones

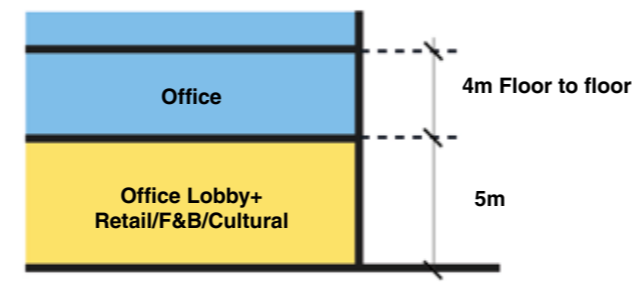

Figure 6.795 Typical floor to floor

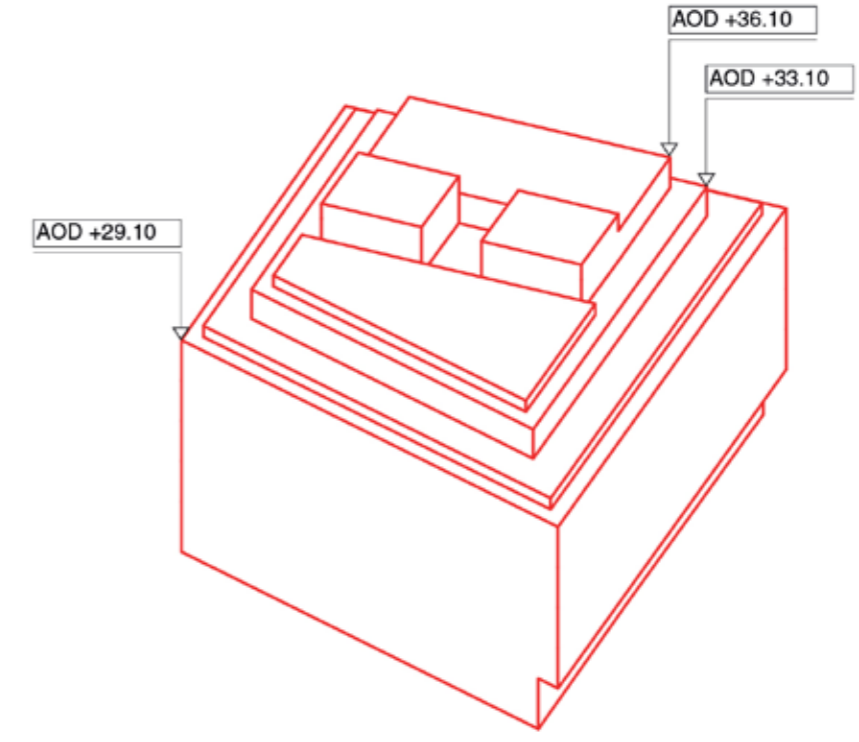

Figure 6.796 Plot G2 Maximum plot parameters

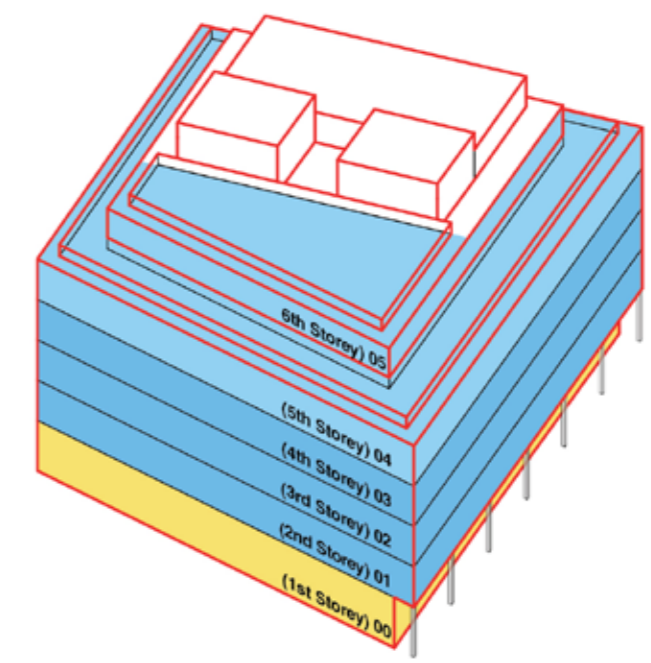

Figure 6.797 Plot G2 Indicative allowable massing set up within maximum plot parameters

6. Plot Guide

6.12 Plot G2

6.12.6 Top of the Building

G2 TOP OF THE BUILDING - ROOF PROFILES

General approach to G2 is to have flat roofs with consistent setbacks, terracing and upstands to reduce the perceived building height and provide edge protection and shelter to the roof top amenity and green spaces.

6.12.6.1 - Upstand, setback and flat roof elements must be incorporated to allow for sheltered greenspaces and terraces.

6.12.6.2 - Accessible terrace zones must be provided and should be set back from the façade by a minimum of 1.5m and have an upstand of minimum 1.1m. See figures 6.799 and 6.800.

6.12.6.3 - Perimeter and setback upstands for shelter and guarding should be provided to all accessible roofs.



Figure 6.798 Plot G2 Rooftop setback plan

Legend

- Maximum plot parameters
- Indicative suggested massing
- Accessible flat roof terrace
- Non-accessible roof
- Indicatively placed Technical/Plant Zones
- Indicative Core Positions

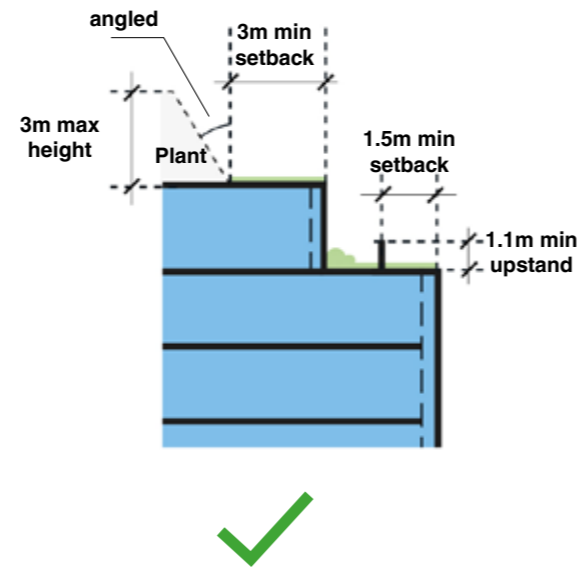

Figure 6.799 Upstand to 1.1m min height and a 1.5m min terrace setback

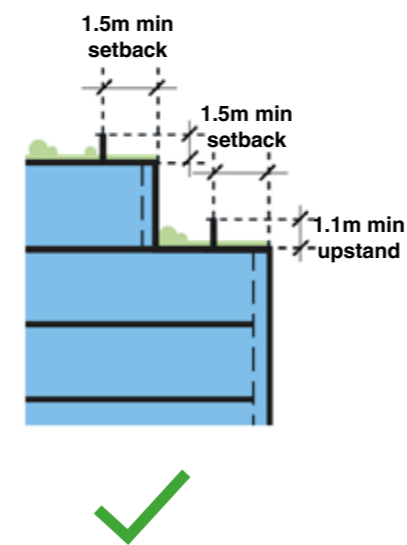

Figure 6.800 Two storey terrace with 1.1m min height upstand and a 1.5m min setback

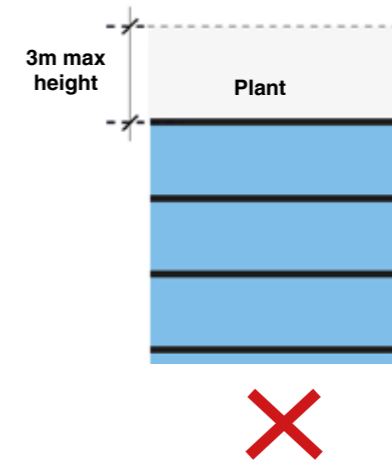

Figure 6.801 No flat non set back plant

6. Plot Guide

6.12 Plot G2

6.12.6 Top of the Building

G2 TOP OF THE BUILDING - ROOF TECHNICAL ZONE

A maximum AOD has been established for Plot G2. The maximum AOD includes a roof top technical zone as indicated in figure 6.827 opposite which is set back from the roof edge.

Where not designated for accessible roof zones, a technical/plant zone exists that encompasses the maximum extents for any final arrangements of required plant.

All core positions, both full storey lobbied roof access extensions or nominal overruns, are shown indicatively.

6.12.6.4 - Any plant must be located within the technical zone and set back a minimum 3m from the façade line with a maximum 3m high enclosure. Plant screens should be included to minimise visual impact when seen from street level. See figure 6.799 on the previous page.

6.12.6.5 - All core positions, both full storey lobbied access extensions or nominal overruns should be located within the technical zones.

6.12.6.6 - Where plant and technical zones cannot be setback 3m or align with the façade edge a façade upstand should be used of a maximum height of 3m.

6.12.6.7 - Green or brown roofs should be provided to all non accessible roof areas.

Legend

- Maximum Plot Parameters
- Indicative Suggested Massing
- Set back zone for Technical/Plant areas (no plant in these areas)
- Maximum Extents available for potential Technical/Plant Zone
- Indicatively placed Technical/Plant Zones
- Indicative Core Positions



Figure 6.802 Plot G2 Maximum extents and setback roof plan

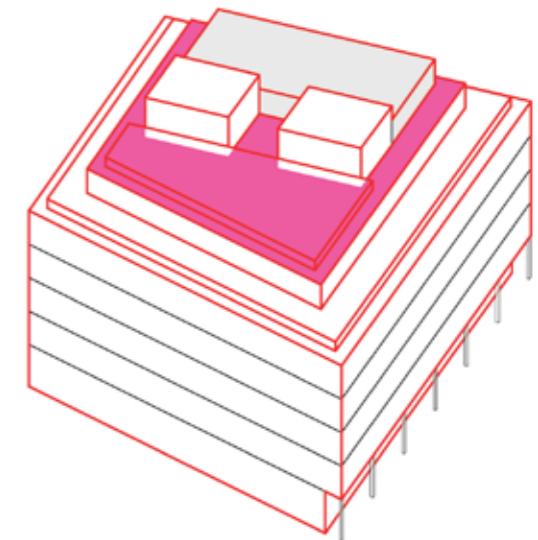

Figure 6.803 Plot G2 Available technical zones within maximum plot parameters

6. Plot Guide

6.12 Plot G2

6.12.7 Middle of the Building

The overall approach is to create an elegant, high-quality building. The façades should provide a strong frontage, contributing to the identity of the IFC development.

The urban analysis (DAS Chapter - 5.8 Approach to Architecture) and the plot's location suggests that the middle of the building should have an expressed structural grid with a vertical emphasis.

The architectural language of each façade should be consistent and a regular sub-grid should be created to provide a hierarchy and ordering principle for the glazing and other façade elements.

The plot location and its 360 orientation will require appropriate façade approaches and should have passive solar control techniques depending on the façade orientation.

6.12.7.1 - The elevations should respond appropriately to their setting and their expression should follow the architectural language of the Commercial Quarter typology.

6.12.7.2 - Devices such as shadow gaps and joint lines should be used to assist the expression the façade sub-divisions and material rhythms.

6.12.7.3 - There must be depth and layering in the articulation of the façades to provide a sense of quality.

6.12.7.4 - Unrelieved stacks of glazing should not be used, instead expressed structure and articulated cladding bays with considered integration of shading devices; louvres/ bris soliels and solid cladding should be used.

6.12.7.5 - Plot G2 and the adjacent plot G3 building envelopes should be considered as a pair of buildings sharing similar approaches to the façade design but should have differences in the materiality tone and detailing.

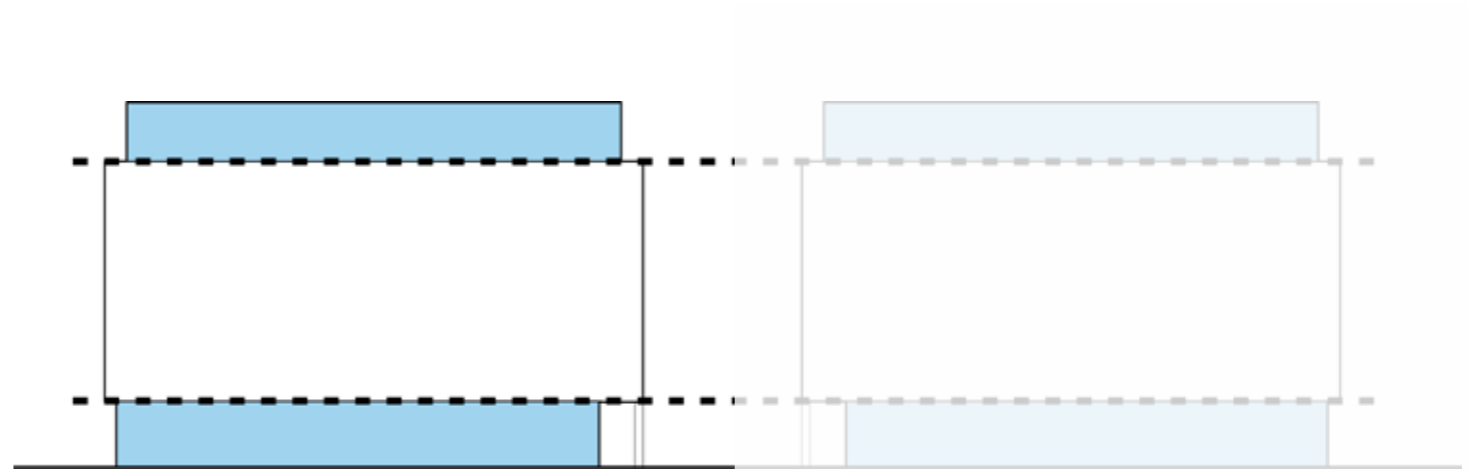

Figure 6.804 Plot G2 Elevation - top, middle, bottom

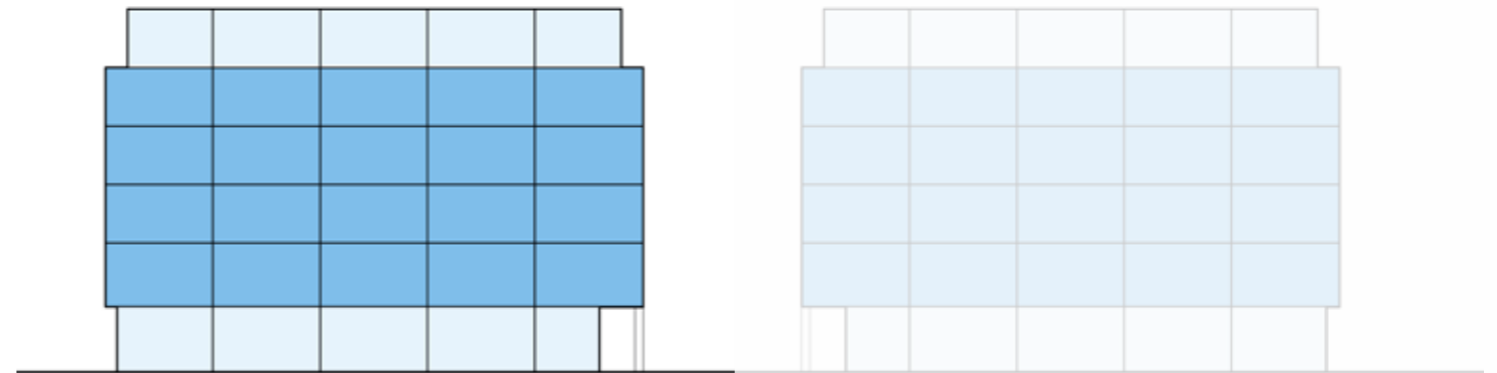

Figure 6.805 Plot G2 Elevation - frontage proportion subdivision

6. Plot Guide

6.12 Plot G2

6.12.8 Bottom of the Building

There may be a number of entrances required on this building including one or more entrances for the different uses at ground level and secondary entrances that include fire escape and/or service entrance(s).

All entrances should be carefully integrated into the façade and should be coherent with the façade material expression.

The plot is on a gradient. The location of the entrances at ground floor level should take into account any variance in external levels.

6.12.8.1 - Entrances must be clearly legible through articulation and design and must have a high quality appearance.

6.12.8.2 - All entrances must be carefully integrated into the design of the building.

6.12.8.3 - Entrances must have level access even where a change in level occurs.

6.12.8.4 - Colonnaded, flush and nominally set back ground façade conditions should exist across Plot G2 with colonnades mandatory where shown. See figure 6.808.

6.12.8.5 - The bottom of the building must have a strong architectural expression (see Chapter 5.9 Bottom of Building).

Legend

- Zone for commercial , culture and F&B entrances
- Zone for office entrances
- Zone for food and beverage



Figure 6.806 Plot G2 bottom of building suggested condition

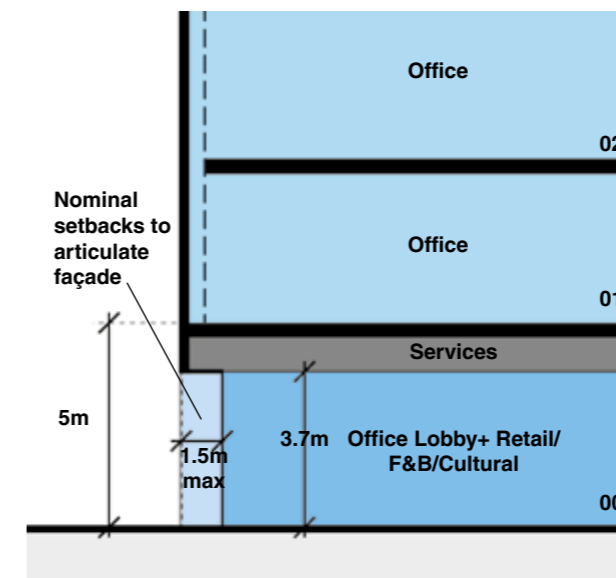

Figure 6.807 Frontage Setback at 1.5m

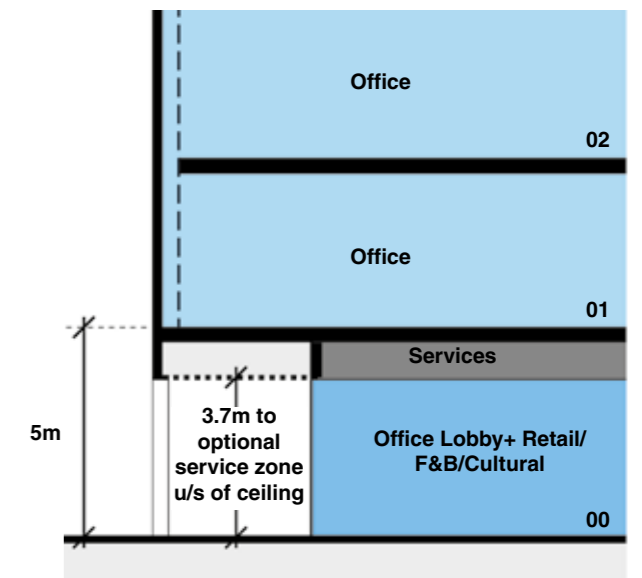

Figure 6.808 Colonnade to help with wind mitigation

6. Plot Guide

6.12 Plot G2

6.12.8 Bottom of the Building

Frontages should be complimentary to the building and provide visual interest at ground level. The bottom of the building has a prime frontage onto the Esplanade Square and forms part of the streetscape and highway experience along the Esplanade.

6.12.8.6 - Plot G2 must provide a range of ground level uses, see chapter 4.1.3 Use Distribution to assist with an activated street frontage.

6.12.8.7 - The bottom of the building must have a strong architectural expression and create an active frontage within the Esplanade Square.

6.12.8.8 - The frontages to any retail or food and beverage uses at ground should be complimentary with the overall material palette of the building. A variety of materials and colours can be used for added detail.

6.12.8.9 - The frontages and entrances should respond to the options for internal office lobby layouts and independent or amalgamated food and beverage, retail and/or cultural uses. See figures 6.809 and 6.810.

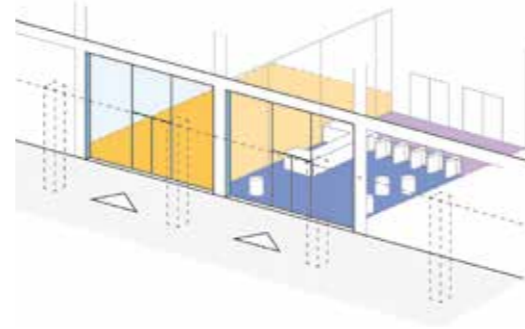

Figure 6.809 Illustrative example of separate entrance for office entrance and retail/food and beverage/cultural uses

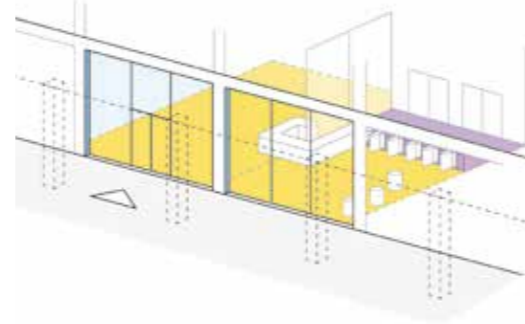

Figure 6.810 Illustrative example of multi-use office entrance lobby

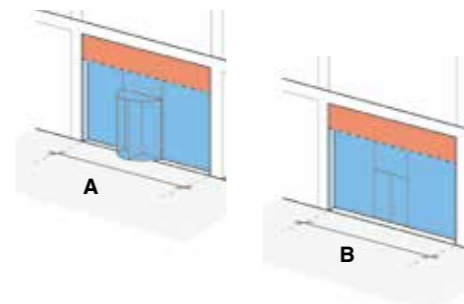

Figure 6.811 Illustrative example of integrated revolving door and wind lobby entrances

Legend

■ Separated F&B/Cultural/Retail uses within commercial curtilage zone

■ Separate dedicated entrance office lobby

■ Post security line lift lobby

■ Shared entrance F&B/Cultural mixed use office lobby within commercial cartilage zone

■ Suggested signage zone when required

■ Suggested base glazed frontages

■ Suggested essential insets of nominal depth per use

A+B Suggested either integrated revolving door (A) or automatic sliding door (B) for office lobbies & any dedicated retail/F&B/culture uses when needed



Figure 6.812 Example of mixed retail uses to ground of commercial building



Figure 6.813 Illustrative example of multi-use office entrance lobby



Figure 6.814 Example of separate entrance for office entrance and retail/food and beverage/cultural uses with glass partition between.

6. Plot Guide

6.12 Plot G2

6.12.9 Adjacent Buildings

Plot G2 is located within close proximity to plots G1 and directly opposite plot G3.

6.12.9.1 - Consideration should be taken to minimise proximity and privacy issues where façades face onto closely adjacent plots such as G3.

6.12.9.2 - Consideration of the accessible roof terrace should be taken to minimise issues between adjacent buildings.

6.12.9.3 - Consideration of window placement and directional framing should be taken where plots are directly adjacent to one another to minimise overlooking, see chapter 5.16 Proximity and Overlooking.

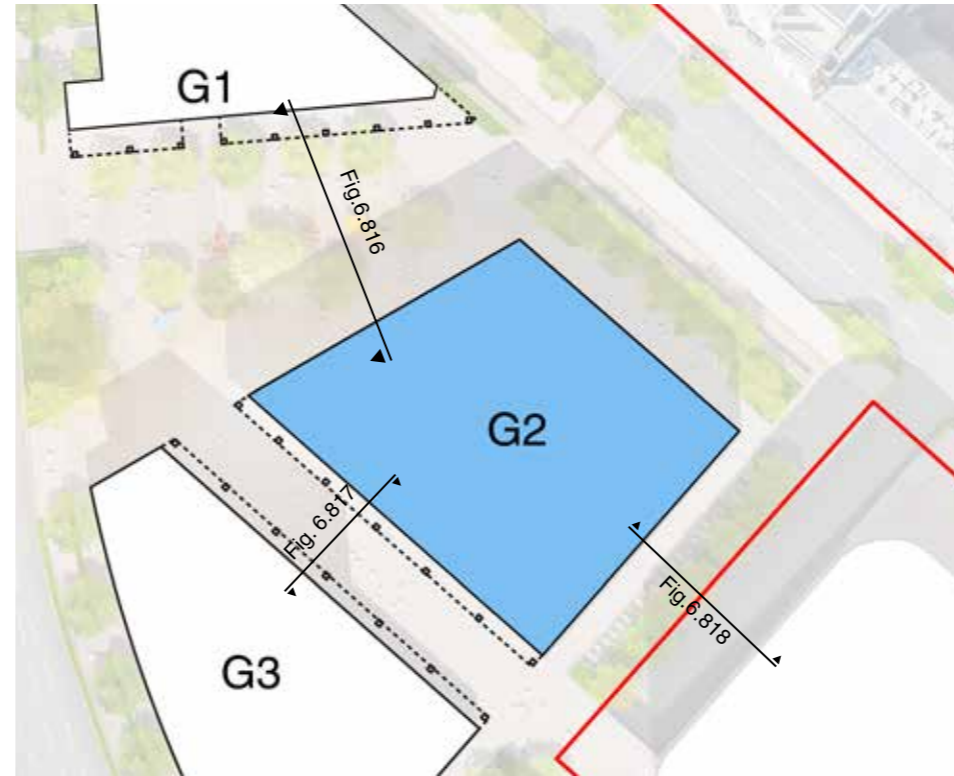

Figure 6.815 Plot G2 Building adjacencies key plan



Figure 6.816 Building adjacency between G1 and G2

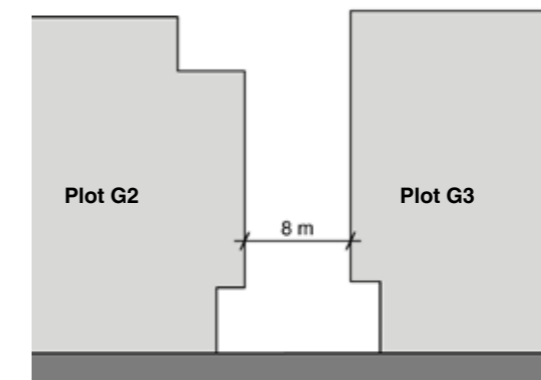

Figure 6.817 Building adjacency between G2 and G3

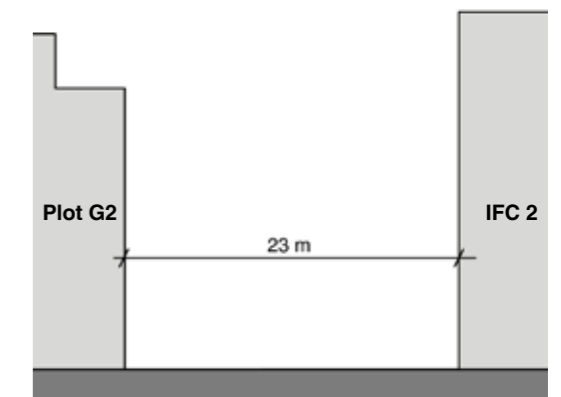

Figure 6.818 Building adjacency between G2 and IFC 2

6. Plot Guide

6.12 Plot G2

6.12.10 Openings

G2 OPENINGS IN THE FAÇADE

Designers should pay careful attention to the placement of openings across the façade. Whilst different opening compositions should be considered, they should also be as part of a coherent façade openings strategy.

The illustrative design for Plot G2 has assumed a curtain wall system with high performance floor to floor glazing typical of the Commercial Quarter typology as the main glazing system.

6.12.10.1 - Consideration should be taken in the use of windows for natural ventilation strategies where appropriate and as linked to any holistic sustainable building services strategy. This includes but is not limited to directly opening window leaves and double skin strategies as illustrated in figures 6.820.

6.12.10.2 - All façades should have a considered level of detail, including the integration of any operable windows for natural ventilation strategies where applicable.

6.12.10.3 - Areas for building services should be treated as screened openings with colour and materiality coordinated with the façade materials (e.g. louvres/ventilation grills), for a coherent elevation strategy. These should be minimised on principal elevations wherever possible.

6.12.10.4 - Consideration for access for the cleaning, maintenance and potential replacement of window elements should be incorporated into the design.

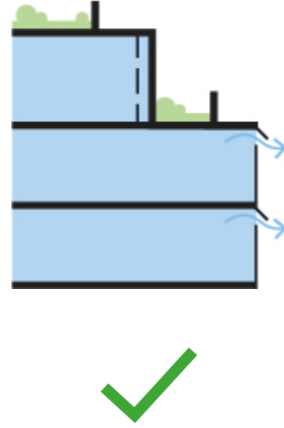

Figure 6.819 Option for operable/automatic sequenced openings to façade for natural/mechanically assisted natural ventilation

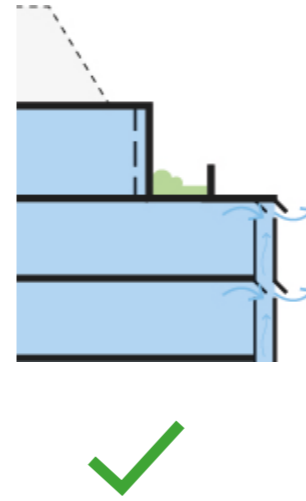

Figure 6.820 Option for operable openings within double skin façade for natural/assisted natural ventilation

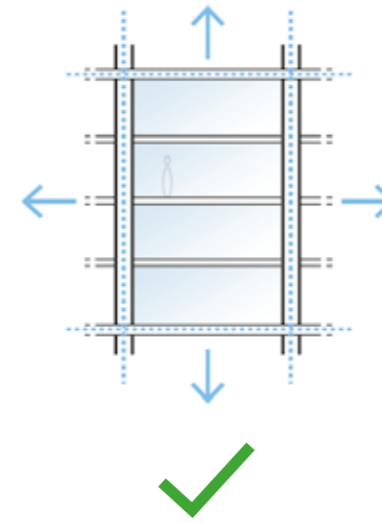

Figure 6.821 Window arrangements to be within regular repeated bays

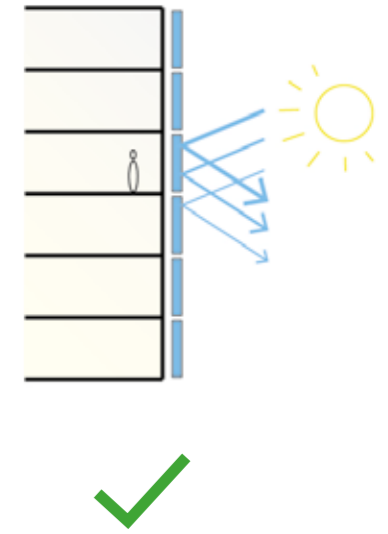

Figure 6.822 Variation of expression of any integrated external shading devices to exposed façades

6. Plot Guide

6.12 Plot G2

6.12.11 Material Appearance

Hard-wearing and long-life quality materials should be selected. This should take inspiration from the existing local façade colours, textures and materials and new or complementary material types can be introduced where appropriate.

Care should be taken when sourcing all materials to ensure minimum environmental impact and the sustainable credentials of the source and the materials lifecycle, see Chapter 6.9 of SWSH Visioning Framework Sustainability Statement for further guidance.

The primary material palette for Plot G2 should be drawn from both the St Helier local stone types in conjunction with a mix of re-constituted stone, concrete/GRC and glazing.

The secondary material palette should include any external shading devices including but not limited to bris soleil/ louvres, integrated façade planting and solid infill zones where required.

The tertiary material palette should be utilised for all framing, detailing and areas of variation or highlight within inset infill zones.

6.12.11.1 - Warm and restrained natural tones of stone should be used in particular local granites and limestones or equivalent reconstituted stones and concretes for areas of expressed structural framing.

6.12.11.2 - Material selection should be responsive to the neighbouring plots including G, G3 and the International Financial Centre.

6.12.11.3 - Promotion of the use of materials that incorporate recycled content and procuring products with a low environmental impact should be a priority when choosing materials. For further guidance see Chapter 6.9 of SWSH Visioning Framework Sustainability Statement.

6.12.11.4 - The secondary material palette should be complementary to the primary composition.

6.12.11.5 - Within any bay arrangements or as part of the overall primary compositions, warm tones of anodised or coated metals and composites, or integrated green planting should be used for external shading devices where required.

6.12.11.6 - The tertiary material palette should be complementary to the primary composition.

6.12.11.7 - The tertiary material palette of warm, more exuberantly coloured and varied materials should be used to add texturing and help detail stand out.

6.12.11.8 - All materials chosen to be hard wearing and must age well in a maritime environment.

6.12.11.9 - Colours for the window frames, door frames, metalwork and other architectural and design features must be complementary to the materials used on the rest of the building.

6.12.11.10 - Highly reflective or 'mirror like' glazing must not be used on any façade.

PRIMARY PALETTE



Figure 6.823 Limestones and Granites



Figure 6.824 Concrete/Re-constituted Stone



Figure 6.825 Glazing

SECONDARY AND TERTIARY PALETTES



Figure 6.827 GRCs and Fibre Cement/Composites, anodised/ coated metals, terracotta/ ceramics and greening.

This Page is Left Intentionally Blank

6. Plot Guide

6.13 Plot G3

6.13.1 Overview

PLOT OVERVIEW

Plot G3 is located in the eastern part of the site and forms one part of the two island plots adjacent to St Heliers International Financial Centre (IFC) developments and will be the latest evolution of the IFC as part of the Framework's Commercial Quarter.

The plot is part of the Commercial Quarter Typology as described in Chapter 5.9 - Architectural Typologies. The office block type has developed in response to the towns need for large floorplan, modern workplace environments capable of attracting international occupiers.

The plots also anchor and activate the southern edge of the proposed new Esplanade Square.

6.13.1.1 - The uses for plot G3 should include food and beverage, retail, arts and culture and office.

6.13.1.2 - Retail, food and beverage, cultural and office lobbies must only be used at ground floor. All floors above must be office use.

6.13.1.3 - The maximum plot parameter diagrams identify the maximum extent permissible of the building and should be read with the parameter plans. See figures 6.831 and 6.832.

6.13.1.4 - All building elements must be within maximum plot extent, with the exception of projecting balconies, canopies and awnings.

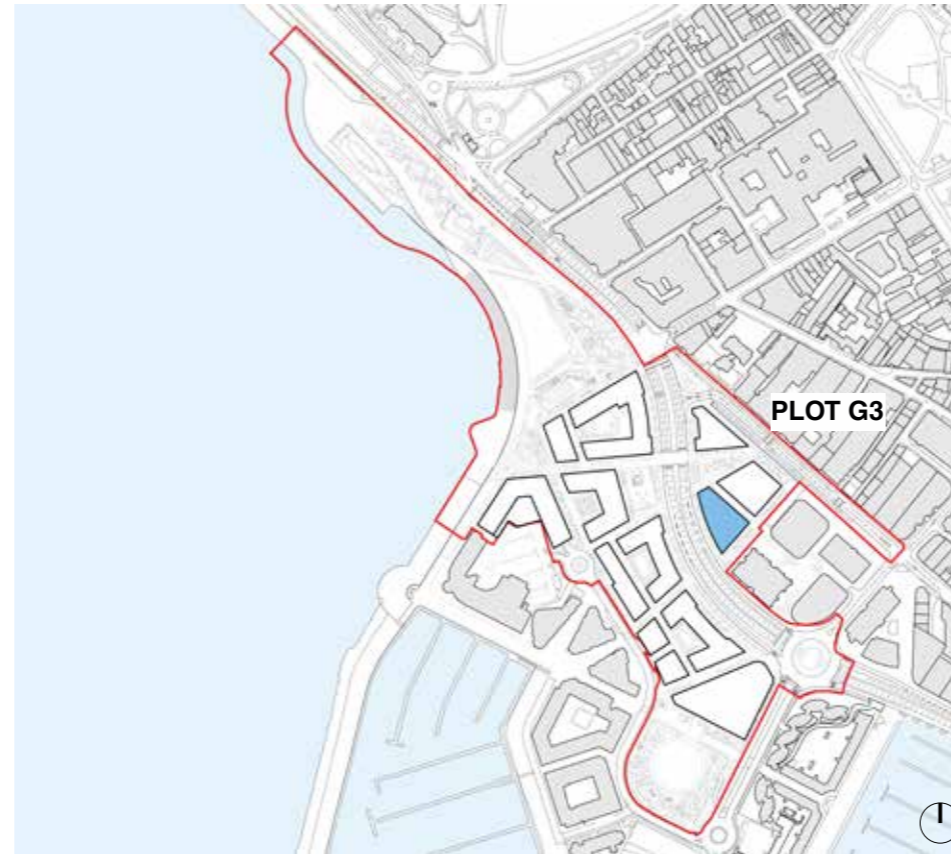

Figure 6.829 Plot parameters key plan

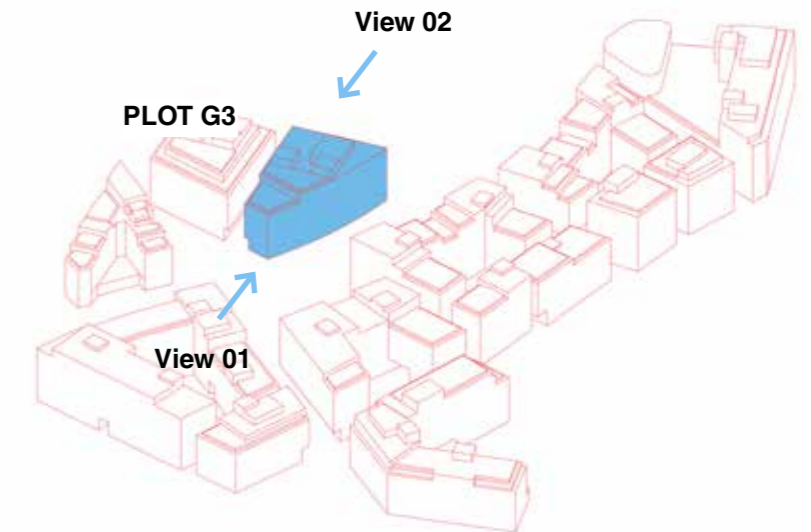

Figure 6.830 Plot parameters key diagram

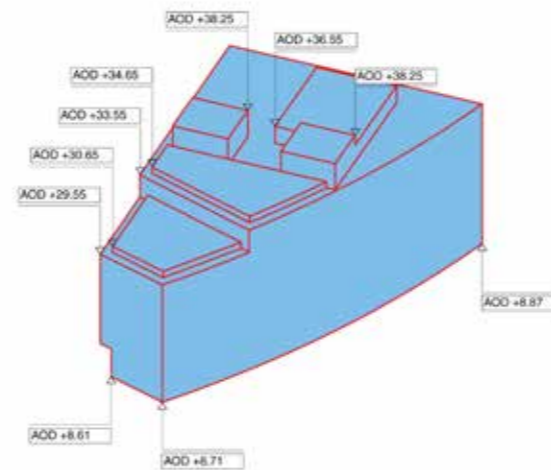

Figure 6.831 Maximum plot parameters diagram - View 01

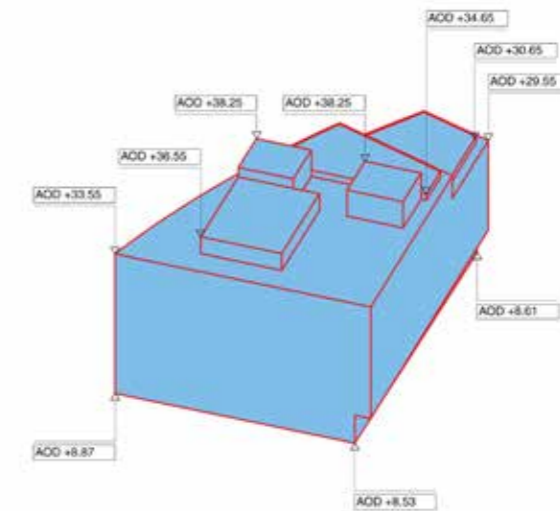

Figure 6.832 Maximum plot parameters diagram - View 02

6. Plot Guide

6.13 Plot G3

6.13.2 Plot Overview

Figure 6.848 provides the key plot dimensions for Plot G3 and indicates its relationship to the illustrative landscaping including the eastern end of the new Esplanade Square between plots G1 and G2.

For further details on dimensions of key routes and codes relating to Plot G3's relationship with the public realm please refer to Chapter 4 - Prescription of future development - Public realm and Open space, of this document set.



Figure 6.833 Plot parameter plan

6. Plot Guide

6.13 Plot G3

6.13.3 General Appearance

The analysis in Chapter - 5.8 Approach to Architecture of the Design and Access statement indicates that the plot should respond in scale and architectural approach to the adjacent existing architecture of the IFC and some of the new contemporary commercial developments along the Esplanade.

Although a continuum of the existing IFC development in scale and reflecting the high quality, contemporary architecture of the IFC, it needs to potentially attract the next generation of occupiers keen to visibly project their socially and environmentally responsible credentials.

The overall approach is to create an impression of a campus of buildings. The façades should provide an active frontage at ground, contributing to the identity of the development.

The architectural language of the façade should be consistent on all four sides of the island plot although the composition may vary to respond to specific site considerations e.g. façade orientation or the provision of colonnades.

6.13.3.1 - The elevations should respond appropriately to their setting and their expression should complement the architectural language of plots G3 and G1.

6.13.3.2 - Plot G3 forms part of the Commercial Quarter typology and should respect the Apex building and the existing IFC buildings opposite.

6.13.3.3 - The building envelope must define a clear base, middle and top through the architectural expression and treatment of the façade. See figure 6.834.

6.13.3.4 - Consideration must be given to how the building interfaces with the ground and the skyline with particular attention to the roofscape including terraces and plant areas in order to minimise vertical impact of these large plots.

6.13.3.5 - There must be depth and layering in the articulation of the façades to provide a sense of quality in particular at ground level where the bottom of building forms a key edge to the Esplanade Square.

6.13.3.6 - Variations in depth, height and materials should be used to break down the horizontal elevation into distinct vertical proportions. See figure 6.852 in 6.13.7 Middle of Building.



Figure 6.834 Plot G3 - The Esplanade Square reference elevation of G3 (with adjacent G2) Top, Middle and Bottom clearly defined by ground and roof treatments

6. Plot Guide

6.13 Plot G3

6.13.4 Wind Mitigation

The impact of wind on the public and private realm environment should be mitigated by the incorporation of design features highlighted in the SWSH Visioning Framework Wind and Microclimate Assessment.

6.13.4.1 - Rooftop balustrades and set backs must be used to G3 terraces as indicated in section 6.13.5 - Top of building.

6.13.4.2 - Colonnades must be introduced where indicated in plans as indicated in figure 6.851 opposite.

6.13.4.3 - Canopies/awnings should be considered where there are no colonnades. See figure 6.852.

6.13.4.4 - Wind mitigation solutions should be complementary to overall architectural typology and integrated into the building design.

6.13.4.5 - The design of plot G3 must incorporate wind mitigation measures as identified in the wind chapter of the EIS, or alternative equivalent measures to achieve the same mitigation effect developed and tested through detailed design.

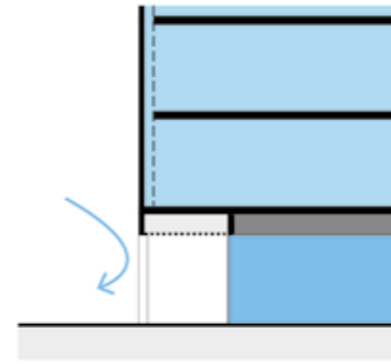

Figure 6.836 Colonnades for wind mitigation

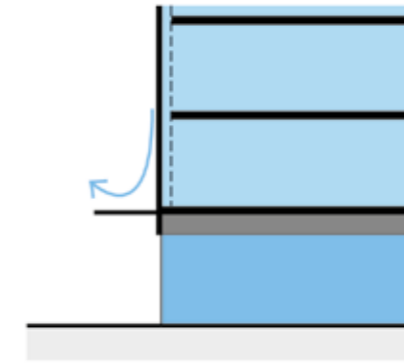

Figure 6.837 Canopy and awning wind for mitigation

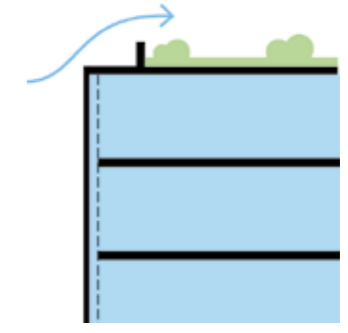

Figure 6.838 Setback upstand for wind mitigation



Figure 6.839 Example of colonnade



Figure 6.840 Example of awnings

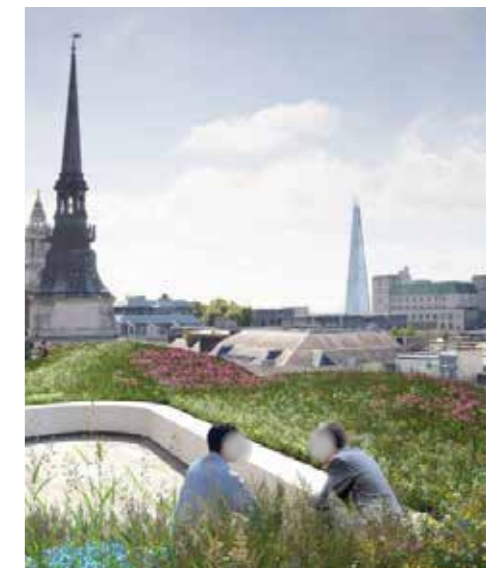

Figure 6.841 Example of 1.1m upstand with planting behind

6. Plot Guide

6.13 Plot G3

6.13.5 Massing

A maximum AOD has been established for Plot G3. It is an island plot and has defined maximum shoulder heights that are consistent on all four elevations. Within these maximum extents the application of architectural treatments such as set backs, terraces and plant screens should be used to help reduce the perceived building height from ground as well as add variation to the roof line.

6.13.5.1 - The ground floor of Plot G1 should be a minimum of 5m floor to floor to maximise the ground level for retail and cultural uses and to activate the frontage onto the Esplanade Square. See figure 6.842 for further guidance.

6.13.5.2 - The maximum number of storeys permissible for plot G3 is 8 storeys (Ground plus 7).

6.13.5.3 - Figure 6.843 identifies the maximum shoulder heights permissible.

6.13.5.4 - The roof top technical zone for Plot G3 has a consistent set back to reduce its vertical impact upon the street below.

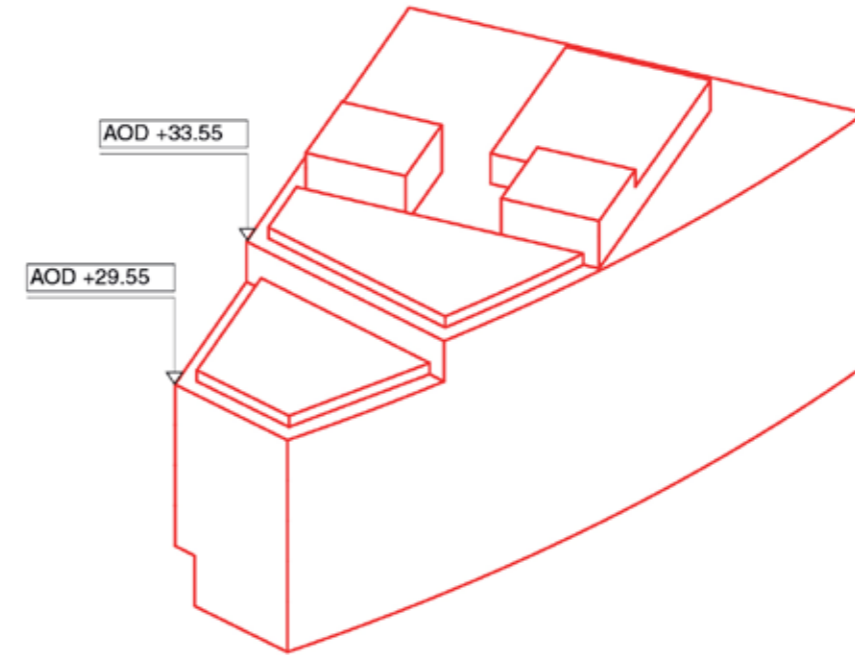

Figure 6.843 Plot G3 Maximum plot parameters

Legend

- Maximum plot parameters
- +5m Floor to floor base zone
- Indicative shaped massing where applicable
- Suggested roof treatment & accessible terrace zones

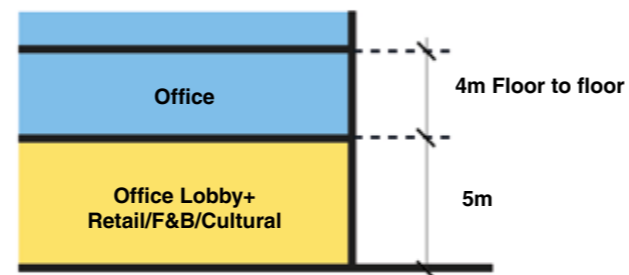

Figure 6.842 Typical floor to floor

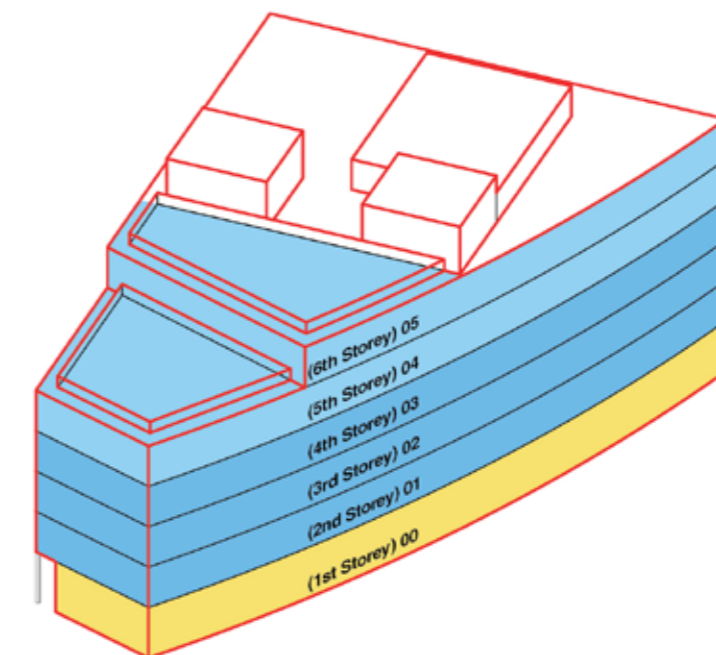

Figure 6.844 Plot G3 Indicative massing set up within maximum plot parameters

6. Plot Guide

6.13 Plot G3

6.13.6 Top of the Building

G3 TOP OF THE BUILDING - ROOF PROFILES

General approach to G3 is to have flat roofs with consistent setbacks, terracing and upstands to reduce the perceived building height and provide edge protection and shelter to the roof top amenity and green spaces.

6.13.6.1 - Upstand, setback and flat roof elements must be incorporated to allow for sheltered greenspaces and terraces.

6.13.6.2 - Accessible terrace zones must be provided and should be set back from the façade by a minimum of 1.5m and have an upstand of minimum 1.1m. See figure 6.847.

6.13.6.3 - Perimeter and setback upstands for shelter and guarding should be provided to all accessible roofs.



Figure 6.845 Plot G3 Rooftop setback plan

Legend

- Maximum plot parameters
- Indicative suggested massing
- Accessible flat roof terrace
- Non-accessible roof
- Indicatively placed Technical/Plant Zones
- Indicative Core Positions

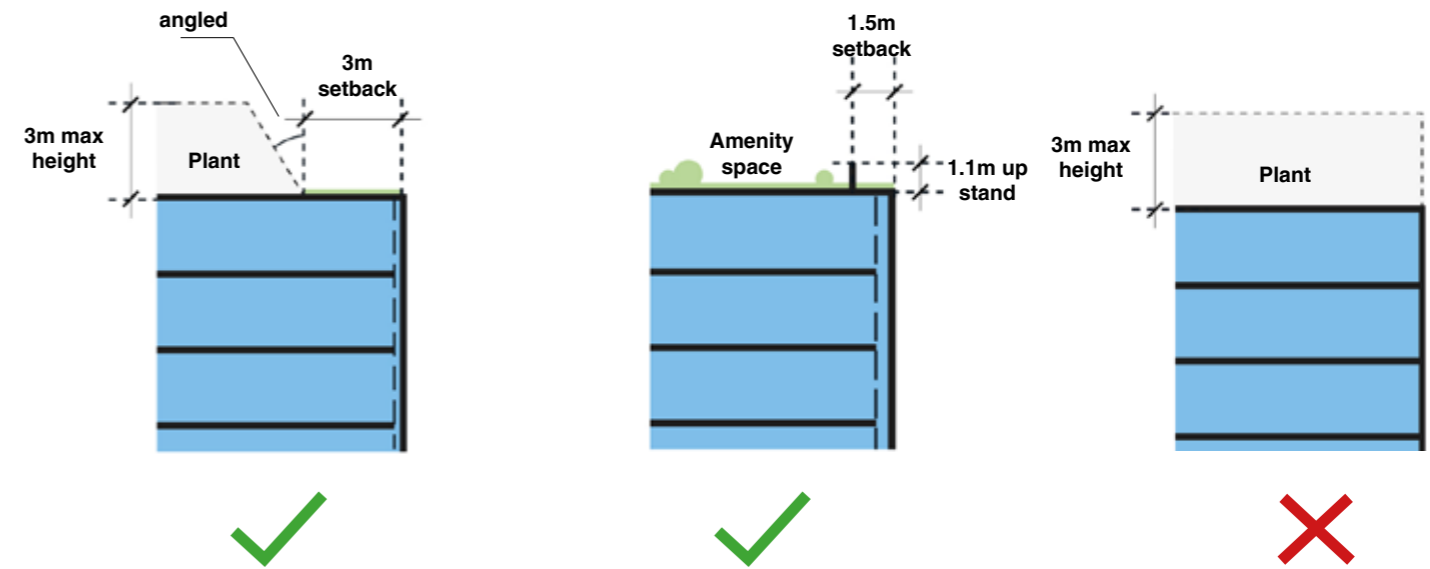

Figure 6.846 Plant to have a 3m min setback

Figure 6.847 Upstand to 1.1m min height and a 1.5m min setback

Figure 6.848 No flat non set back plant

6. Plot Guide

6.13 Plot G3

6.13.6 Top of the Building

G3 TOP OF BUILDING - ROOF TECHNICAL ZONE

A maximum AOD has been established for Plot G3. The maximum AOD includes a roof top technical zone as indicated in figure 6.875 opposite which is set back from the roof edge.

Where not designated for accessible roof zones, a technical/plant zone exists that encompasses the maximum extents for any final arrangements of required plant.

All core positions, both full storey lobbied roof access extensions or nominal overruns, are shown indicatively.

6.13.6.4 - Any plant must be located within the technical zone and set back a minimum 3m from the façade line with a maximum 3m high enclosure. Plant screens should be included to minimise visual impact when seen from street level. See figure 6.846 on previous page.

6.13.6.5 - All core positions, both full storey lobbied access extensions or nominal overruns should be located within the technical zones.

6.13.6.6 - Where plant and technical zones cannot be setback 3m or align with the façade edge a façade upstand should be used of a maximum height of 3m.

6.13.6.7 - Green or brown roofs should be provided to all non accessible roof areas.

Legend

- Maximum Plot Parameters
- Indicative Suggested Massing
- Set back zone for Technical/Plant areas (no plant in these areas)
- Maximum Extents available for potential Technical/Plant Zone
- Indicatively placed Technical/Plant Zones
- Indicative Core Positions



Figure 6.849 Plot G3 Maximum extents and setback roof plan

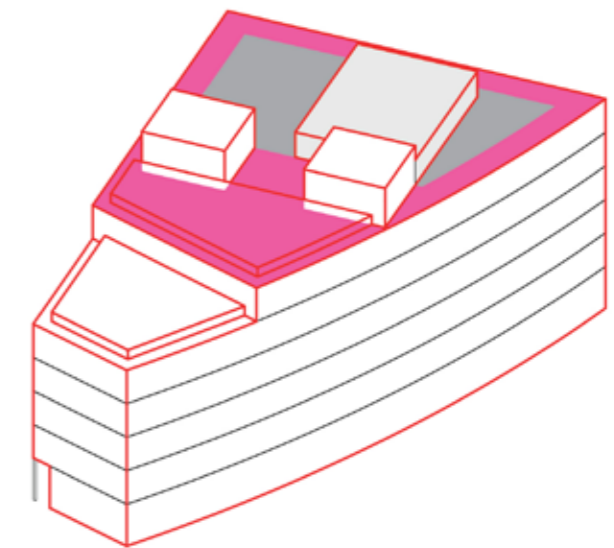

Figure 6.850 Plot G3 Available technical zones within maximum plot parameters

6. Plot Guide

6.13 Plot G3

6.13.7 Middle of the Building

The overall approach is to create an elegant, high-quality building. The façades should provide a strong frontage, contributing to the identity of the IFC development.

The urban analysis (DAS Chapter - 5.8 Approach to Architecture) and the plot's location suggests that the middle of the building should have an expressed structural grid with a vertical emphasis.

The architectural language of each façade should be consistent and a regular sub-grid should be created to provide a hierarchy and ordering principle for the glazing and other façade elements.

The plot location and its 360 orientation will require appropriate façade approaches and should have passive solar control techniques depending on the façade orientation.

6.13.7.1 - The elevations should respond appropriately to their setting and their expression should follow the architectural language of the Commercial Quarter typology.

6.13.7.2 - Devices such as shadow gaps and joint lines should be used to assist the expression the façade sub-divisions and material rhythms.

6.13.7.3 - There must be depth and layering in the articulation of the façades to provide a sense of quality.

6.13.7.4 - Unrelieved stacks of glazing should not be used, instead expressed structure and articulated cladding bays with considered integration of shading devices; louvres/ bris soliels and solid cladding should used.

6.13.7.5 - Plot G3 and the adjacent plot G2 building envelopes should be considered as a pair of buildings sharing similar approaches to the façade design but should have differences in the materiality tone and detailing.

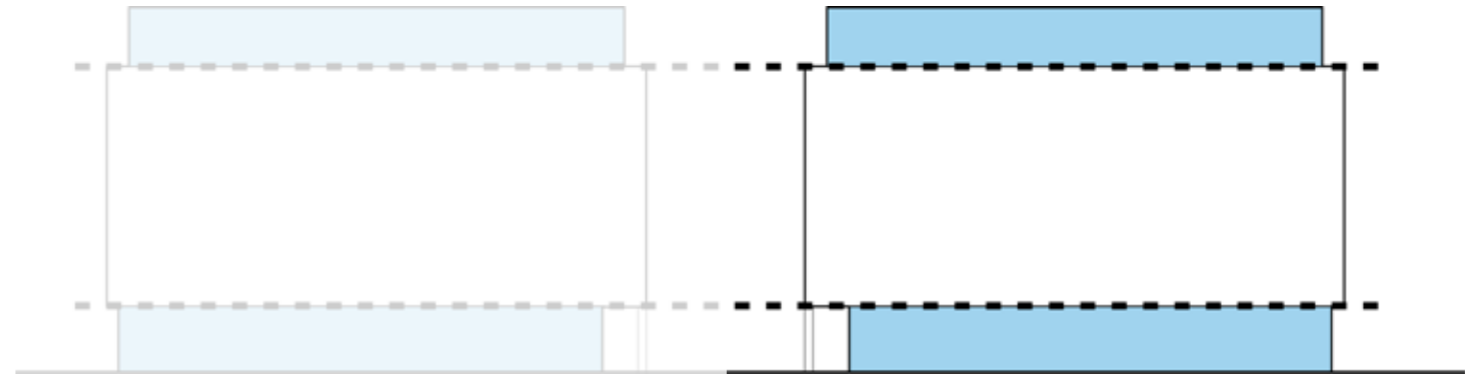

Figure 6.852 Plot G3 Elevation - top, middle, bottom

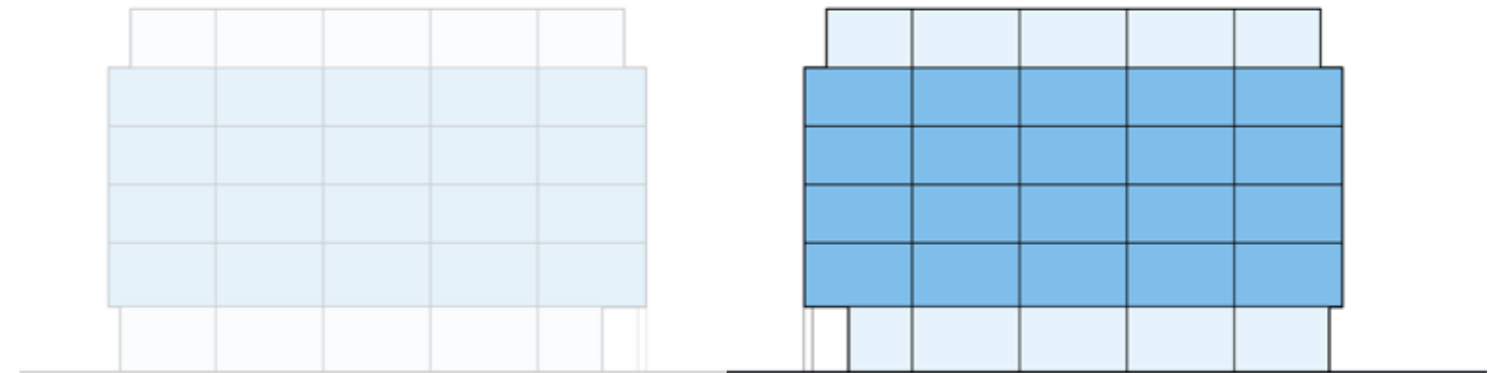

Figure 6.851 Plot G3 Elevation - frontage proportion subdivision

6. Plot Guide

6.13 Plot G3

6.13.8 Bottom of the Building

There may be a number of entrances required on this building including one or more entrances for the different uses at ground level and secondary entrances that include fire escape and/or service entrance(s).

All entrances should be carefully integrated into the façade and should be coherent with the façade material expression.

The plot is on a gradient. The location of the entrances at ground floor level should take into account any variance in external levels.

6.13.8.1 - Entrances must be clearly legible through articulation and design and must have a high quality appearance.

6.13.8.2 - All entrances must be carefully integrated into the design of the building.

6.13.8.3 - Entrances must have level access even where a change in level occurs.

6.13.8.4 - Colonnaded, flush and nominally set back ground façade conditions should exist across Plot G3 with colonnades mandatory where shown. See figure 6.855.

6.13.8.5 - The bottom of the building must have a strong architectural expression (see Chapter 5.9 Bottom of Building).

Legend

- █ Zone for commercial, culture and F&B entrances
- █ Zone for office entrances
- █ Zone for food and beverage



Figure 6.853 Plot G3 bottom of building suggested condition

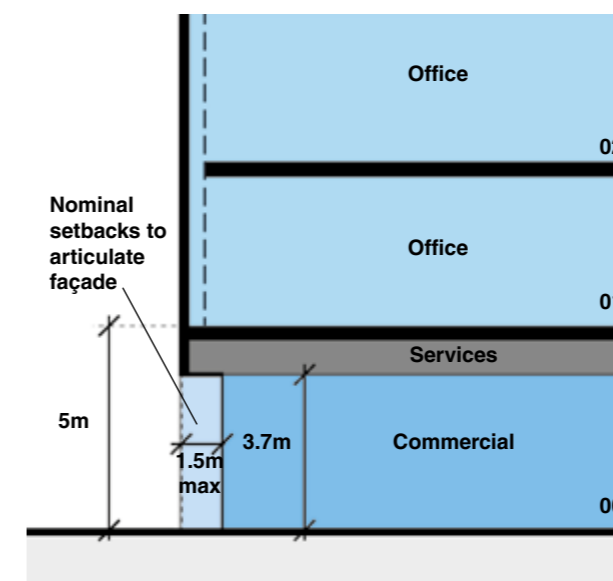

Figure 6.854 Frontage Setback at 1.5m

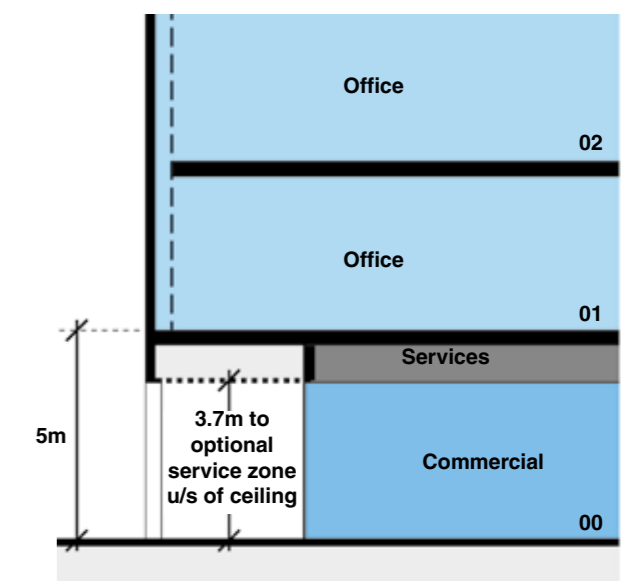

Figure 6.855 Colonnade to help with wind mitigation

6. Plot Guide

6.13 Plot G3

6.13.8 Bottom of the Building

Frontages should be complimentary to the building and provide visual interest at ground level. The bottom of the building has a prime frontage onto the Esplanade Square and forms part of the streetscape and highway experience along the Esplanade.

6.13.8.6 - Plot G3 must provide a range of ground level uses. See chapter 4.1.3 Use Distribution to assist with an activated street frontage.

6.13.8.7 - The bottom of the building must have a strong architectural expression and create an active frontage within the Esplanade Square.

6.13.8.8 - The frontages to any retail or food and beverage uses at ground should be complimentary with the overall material palette of the building. A variety of materials and colours can be used for added detail.

6.13.8.9 - The frontages and entrances should respond to the options for internal office lobby layouts and independent or amalgamated food and beverage, retail and/or cultural uses. See figures 6.856 and 6.857.

Legend

 Separated F&B/Cultural/Retail uses within commercial curtilage zone

 Separate dedicated entrance office lobby

 Post security line lift lobby

 Shared entrance F&B/Cultural mixed use office lobby within commercial cartilage zone

 Suggested signage zone when required

 Suggested base glazed frontages

 Suggested essential insets of nominal depth per use

A+B Suggested either integrated revolving door (A) or automatic sliding door (B) for office lobbies & any dedicated retail/F&B/culture uses when needed

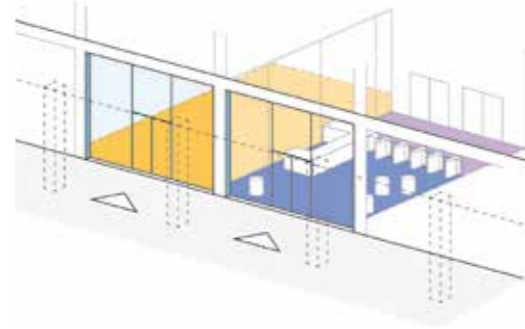

Figure 6.856 Illustrative example of separate entrance for office entrance and retail/food and beverage/cultural uses

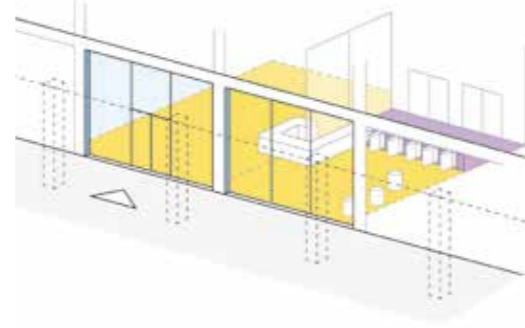

Figure 6.857 Illustrative example of multi-use office entrance lobby

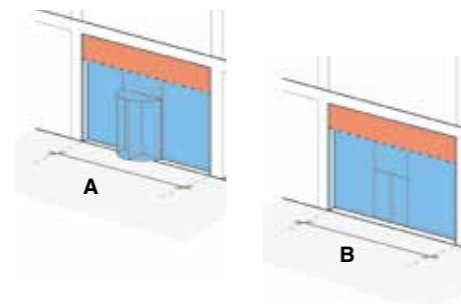

Figure 6.858 Illustrative example of integrated revolving door and wind lobby entrances



Figure 6.859 Example of mixed retail uses to ground of commercial building



Figure 6.860 Illustrative example of multi-use office entrance lobby



Figure 6.861 Example of separate entrance for office entrance and retail/food and beverage/cultural uses with glass partition between.

6. Plot Guide

6.13 Plot G3

6.13.9 Adjacent Buildings

Plot G3 is located within close proximity to plots G1 and directly opposite plot G2.

6.13.9.1 - Consideration should be taken to minimise proximity and privacy issues where façades face onto closely adjacent plots such as G2.

6.13.9.2 - Consideration of the accessible roof terrace should be taken to minimise issues between adjacent buildings.

6.13.9.3 - Consideration of window placement and directional framing should be taken where plots are directly adjacent to one another to minimise overlooking. See chapter 5.16 Proximity and Overlooking.



Figure 6.862 Plot G3 Building adjacencies key plan

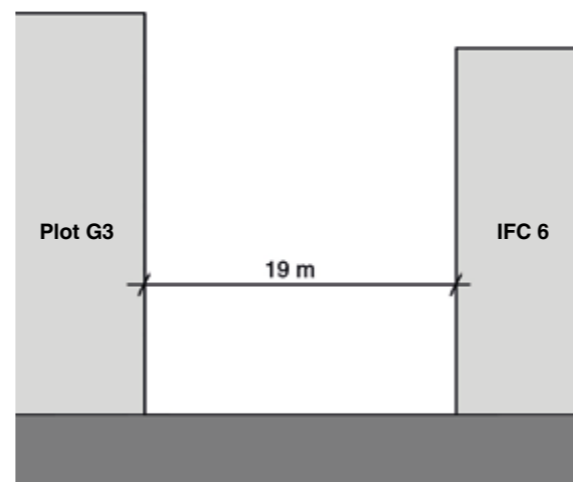

Figure 6.863 Building adjacency between G3 and IFC 6

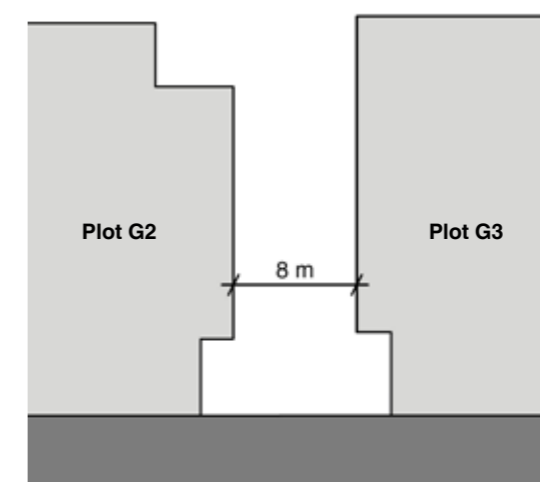

Figure 6.864 Building adjacency between G3 and G2

6. Plot Guide

6.13 Plot G3

6.13.10 Openings

G3 OPENINGS IN THE FAÇADE

Designers should pay careful attention to the placement of openings across the façade. Whilst different opening compositions should be considered, they should also be as part of a coherent façade openings strategy.

The illustrative design for Plot G3 has assumed a curtain wall system with high performance floor to floor glazing typical of the Commercial Quarter typology as the main glazing system.

6.13.10.1 - Consideration should be taken in the use of windows for natural ventilation strategies where appropriate and as linked to any holistic sustainable building services strategy. This includes but is not limited to directly opening window leaves and double skin strategies as illustrated in figures 6.865 and 6.866.

6.13.10.2 - All façades should have a considered level of detail, including the integration of any operable windows for natural ventilation strategies where applicable.

6.13.10.3 - Areas for building services should be treated as screened openings with colour and materiality coordinated with the façade materials (e.g. louvres/ventilation grills), for a coherent elevation strategy. These should be minimised on principal elevations wherever possible.

6.13.10.4 - Consideration for access for the cleaning, maintenance and potential replacement of window elements should be incorporated into the design.

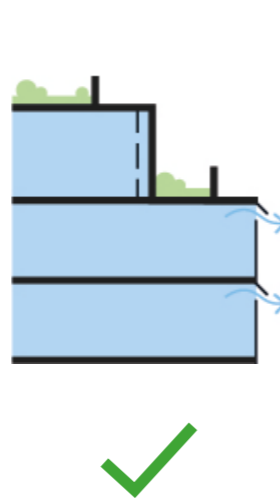

Figure 6.865 Option for operable/automatic sequenced openings to façade for natural/mechanically assisted natural ventilation

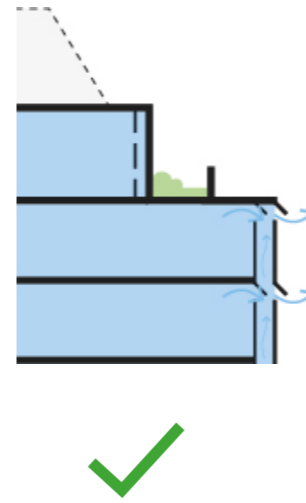

Figure 6.866 Option for operable openings double skin façade for natural/assisted natural ventilation façade system(s)

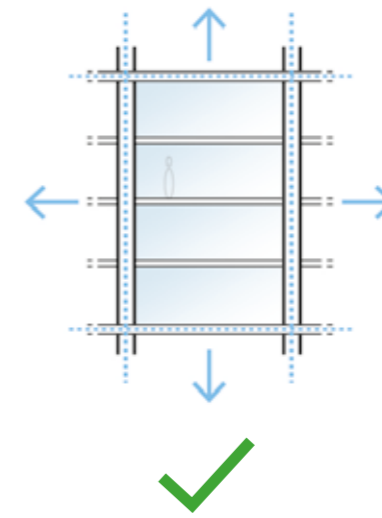

Figure 6.867 Window set ups to be within regular repeated bays

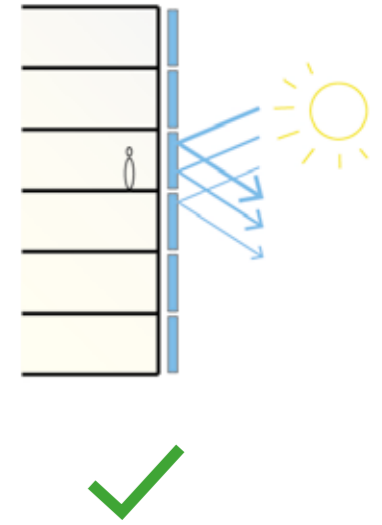

Figure 6.868 Variation of expression of any integrated external shading devices to exposed façades

6. Plot Guide

6.13 Plot G3

6.13.11 Material Appearance

Hard-wearing and long-life quality materials should be selected. This should take inspiration from the existing local façade colours, textures and materials and new or complementary material types can be introduced where appropriate.

Care should be taken when sourcing all materials to ensure minimum environmental impact and the sustainable credentials of the source and the materials lifecycle. See Chapter 6.9 of SWSH Visioning Framework Sustainability Statement for further guidance.

The primary material palette for Plot G3 should be drawn from both the St Helier local stone types in conjunction with a mix of re-constituted stone, concrete/GRC and glazing.

The secondary material palette should include any external shading devices including but not limited to bris soleil/ louvres, integrated façade planting and solid infill zones where required.

The tertiary material palette should be utilised for all framing, detailing and areas of variation or highlight within inset infill zones.

6.13.11.1 - Warm and restrained natural tones of stone should be used in particular local granites and limestones or equivalent reconstituted stones and concretes for areas of expressed structural framing.

6.13.11.2 - Material selection should be responsive to the neighbouring plots including G, G3 and the International Financial Centre.

6.13.11.3 - Promotion of the use of materials that incorporate recycled content and procuring products with a low environmental impact should be a priority when choosing materials. For further guidance see Chapter 6.9 of SWSH Visioning Framework Sustainability Statement.

6.13.11.4 - The secondary material palette should be complementary to the primary composition.

6.13.11.5 - Within any bay arrangements or as part of the overall primary compositions, warm tones of anodised or coated metals and composites, or integrated green planting should be used for external shading devices where required.

6.13.11.6 - The tertiary material palette should be complementary to the primary composition.

6.13.11.7 - The tertiary material palette of warm, more exuberantly coloured and varied materials should be used to add texturing and help detail stand out.

6.13.11.8 - All materials chosen to be hard wearing and must age well in a maritime environment.

6.13.11.9 - Colours for the window frames, door frames, metalwork and other architectural and design features must be complementary to the materials used on the rest of the building.

6.13.11.10 - Highly reflective or 'mirror like' glazing must not be used on any façade.

PRIMARY PALETTE



Figure 6.869 Limestones and Granites



Figure 6.870 Concrete/Re-constituted Stone



Figure 6.871 Glazing

SECONDARY AND TERTIARY PALETTES



Figure 6.873 GRCs and Fibre Cement/Composites, anodised/ coated metals, terracotta/ ceramics and greening.

This Page is Left Intentionally Blank